



## Elite Series Fender Flares

**For proper installation and best possible fit, please read all instructions BEFORE you begin.  
For technical assistance or to obtain missing parts, please call Customer Relations at 1-800-241-7219.**

### Important Safety Information



- CAUTION - Before driving, ensure that the fender flare is properly secured to vehicle.
- Do not use automatic "brush-style" car washes.
- Do not use cleaning solvents of any kind.
- Periodically check all components for tightness.

### Contents

**NOTE:** Actual product may vary from illustration.

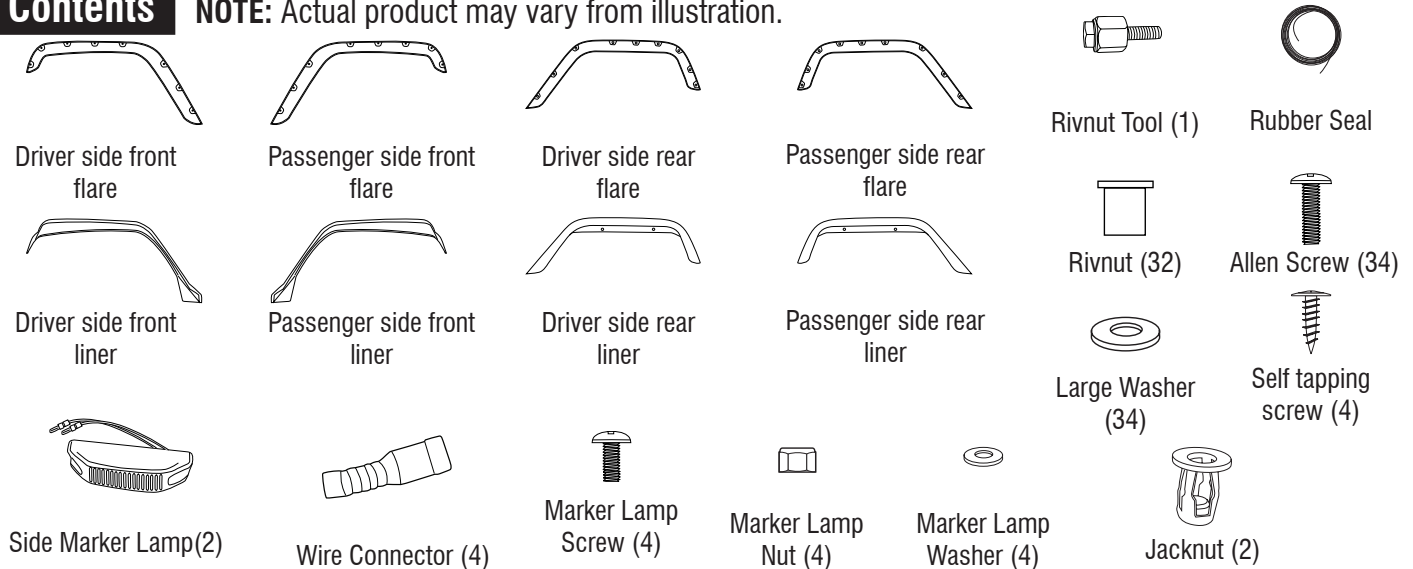

### Tools Required

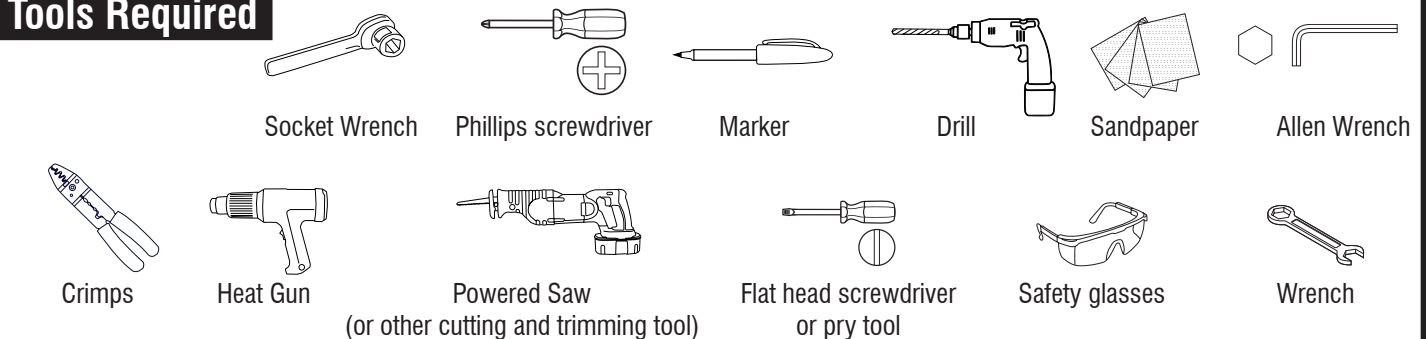

### Preparation Before Painting / Installation

#### Custom Paint Job (Optional)

Please test fit all the flares first to ensure you have the correct flares for your vehicle. We are not responsible for any costs you may incur if you did not confirm the flares before having it painted. We recommend hiring professionals to custom paint the products. It is also ideal to have the painting done prior to the installation to eliminate any over-spraying issues.

#### Cleaning the vehicle

Make sure to wash your vehicle, especially the area the fender flares will be mounted to including the inner fender lip after removing the original fender flare and splash guard assembly. Any dirt or debris that has not been cleaned or removed can potentially cause the improper fitment of the fender flare. If you are covering existing rust, we recommend sanding down the rust and primer over to prevent further deterioration of the metal in the fender. Make sure the vehicle is dry before the installation. The fender flares come ready to be installed, however if you need to clean them, please use a mild detergent to wash and then dry completely.

#### Professional installation (optional)

While every effort has been made to make this installation as simple as possible, professional installation may be advisable in some instances.

# Installation Steps **NOTE:** Actual application may vary slightly from illustrations.

Remove (4) factory bolts from inside of splash shield.  
Save bolts for reinstallation.



1

Remove (2) additional factory bolts from  
inside of splash shield. Save bolts.

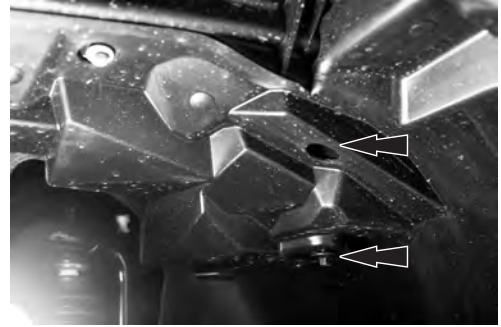

2

Disconnect the side marker lamp from the lens housing.



3

Starting at the front of the fender flare, pull to remove the flare and splash shield assembly from the vehicle fender. **NOTE:** You may notice loud popping noises as clips release, this is normal.



4

Remove any remaining retaining clips still attached to fender and clean fender edge.



5

Remove (4) plastic fasteners from the flare and splash shield assembly.

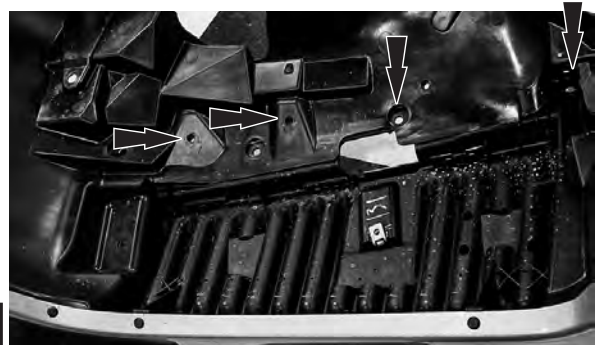

6

Drill out (6) plastic rivets along the edge of the flare and splash shield assembly.



7

Separate fender flare from splash shield. Reinstall splash shield only on fender, prior to marking for cutting.



8

# Installation Steps **NOTE:** Actual application may vary slightly from illustrations.

Mark the splash shield in the front with a marker in preparation for cutting. The splash shield **MUST** be flush with sheet metal after trimming. **NOTE:** Exercise extreme caution while trimming. If done improperly flare will not fit.



9

Mark the splash shield in the rear with a marker in preparation for cutting. The splash shield **MUST** be flush with sheet metal after trimming. **NOTE:** Exercise extreme caution while trimming. If done improperly flare will not fit.



10

Remove splash shield from vehicle and carefully trim splash shield along the marked lines made in **Steps 9 and 10**.



11

Place splash shield back into position on fender. Ensure all edges are flush with fender sheet metal. If necessary, remove splash shield and sand / trim as needed to attain flush fit. Reinstall previously removed bolts and secure splash shield in place.



12



Place a rivnut on the rivnut tool.



13

Insert rivnut in fender hole.



14

Using a wrench to hold rivnut tool in place, install rivnut in place on fender using an 11/16" socket. The rivnut will expand to secure itself in place. **NOTE:** Use of impact driver recommended for rivnut installation.



15

Remove rivnut tool. Repeat for remaining holes.



16

**Installation Steps** NOTE: Actual application may vary slightly from illustrations.

Place new fender liner in position and align with holes.

17



Reinstall (3) bolts to secure fender liner in place.

18

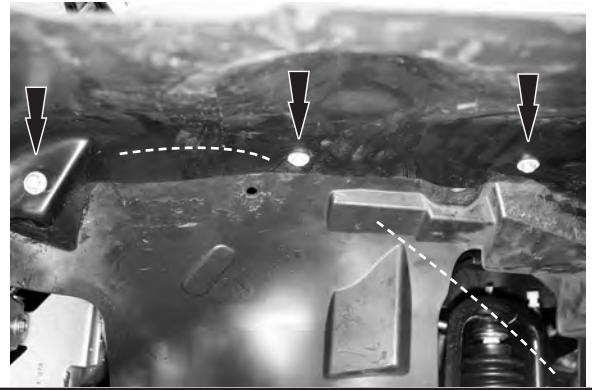

Cut (2) wires at the base of the side marker lamp that was removed in **Step 2** and remove factory connector.

19



Use wire strippers to remove approximately 1/2" of wire covering, and install a wire connector to the end of each side marker lamp wire, and crimp.

20



Using a heat gun, seal the shrink tubing to the wires.

21



Place the provided side marker light onto the new fender flare and insert wires through the predilled hole.

22



Attach the side marker lamp to the fender flare using screw, nut, and washer provided. Reconnect to wiring harness.



23



Use a razor blade to cut and install rubber seal on the new fender flare edge, that will mount against fender.

24



# Installation Steps **NOTE:** Actual application may vary slightly from illustrations.

Carefully place new fender flare on fender liner and align with holes in fender.



25

Reconnect side marker light.



26



Beginning at the back, install allen screws and large washers in all holes and hand tighten. Continue from rear to front and snug all fasteners.



27



Install (1) self tapping screw through hole in fender flare liner closest to cab.



28

Repeat Steps 1 thru 28 for opposite side front.

## Rear Flares

Remove (5) plastic christmas tree fasteners from inside of splash shield at rear wheel well. **NOTE:** Retain fasteners for reinstallation later.

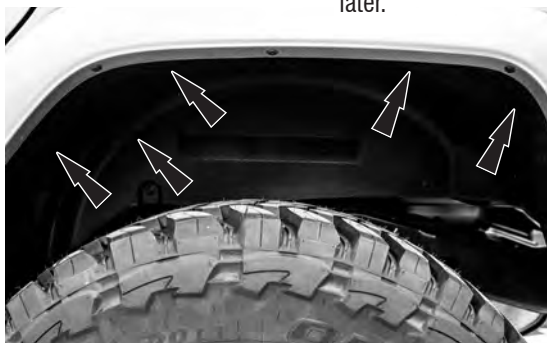

29

Starting at the front of the fender flare, pull to remove the flare and splash shield assembly from the vehicle fender. **NOTE:** You may notice loud popping noises as clips release, this is normal.



30

Remove any remaining retaining clips still attached to fender and clean fender edge.



31

Drill out (6) plastic rivets along the edge of the flare and splash shield assembly. Separate flare from splash shield.



32

**Installation Steps** NOTE: Actual application may vary slightly from illustrations.

Reinstall splash shield temporarily using (2) previously removed christmas tree fasteners.



33

Mark the front and rear portions of the splash shield in preparation for cutting. The splash shield MUST be flush with sheet metal after trimming. NOTE: Exercise extreme caution while trimming. If done improperly flare will not fit.



34

Remove splash shield from vehicle and trim splash shield along the marked lines made in **Step 33**. Use sandpaper or grinder to smooth edges as necessary.



35

Reinstall splash shield.



36



Repeat **Steps 13 thru 16** to install rivnuts in fender.



37



Place a jacknut on the rivnut tool.



38

On the second hole from the front will be a larger hole. Install (1) jacknut using rivnut tool. Repeat **Steps 15 and 16** to complete jacknut installation.



39

Place new fender liner in position and align with holes.



40

## Installation Steps

**NOTE:** Actual application may vary slightly from illustrations.

Reinstall (3) bolts to secure fender liner in place.



41



Use a razor blade to cut and install rubber trim on the new fender flare edge, that will mount against fender.



42

Carefully place new fender flare on fender liner and align with holes in fender. **NOTE:** On the second hole from the front will be a blank hole that does not correspond to the holes in the fender. Thread a screw through the hole and secure tightly with a rivnut.



43



Beginning at the rear, install allen screws and large washer in all holes and hand tighten.



44

Continue from rear to front and snug all fasteners.



45



Install (1) self tapping screw through hole in fender flare liner closest to cab.



46

Repeat **Steps 29 thru 46** for opposite side rear.

## Care and Cleaning

- Lund fender flares are built to last; any detergent you use to wash your vehicle is sufficient to clean the flares. Do not use any harsh abrasive detergents.

## Congratulations!

You have purchased one of the many quality Lund<sup>®</sup> branded products offered by Lund International, Inc. We take the utmost pride in our products and want you to enjoy years of satisfaction from your investment. We have made every effort to ensure that your product is top quality in terms of fit, durability, finish and ease of installation.

# LUND<sup>®</sup>

Lund International

800-241-7219 • Visit us at [lundinternational.com](http://lundinternational.com)

© 2014 Lund International, Inc. All rights reserved.

Lund<sup>®</sup> and the Lund<sup>®</sup> logo are trademarks of Lund International, Inc.

