



FREEDOM Modular Bed Rack Assembly Instructions

2020 Jeep Gladiator JT

ICD Design, LLC is not responsible for any damage that may occur during installation.

This is a general assembly manual and may vary by the Gladiator's versions and options. Please consult our technical department for more information and assistance.

This manual is for the Jeep Gladiator with and without the factory sliding bed rail. It contains all the hardware for a no drill and drilling applications.

PARTS:

- ✓ 2 Cross Bars
- ✓ 4 Base Legs
- ✓ 2 Side Bars
- ✓ 2 Top Bars
- ✓ Hardware:

Assembly:

32 each. Carriage Bolt 3/8"-16 X 1.0" long, Zinc plated steel, grade 5

32 each. Lock nut, 3/8"-16, Zinc plated steel, grade 5

32 each. Flat Washer, 3/8"-16, Zinc plated steel, grade 5

Mounting to Truck Bed:

8 each. Hex Head Bolt 3/8"-16 X 1.0" long, Zinc plated steel, grade 5

8 each. Lock nut, 3/8"-16, Zinc plated steel, grade 5

8 each. Flat Washer, 3/8"-16, Zinc plated steel, grade 5

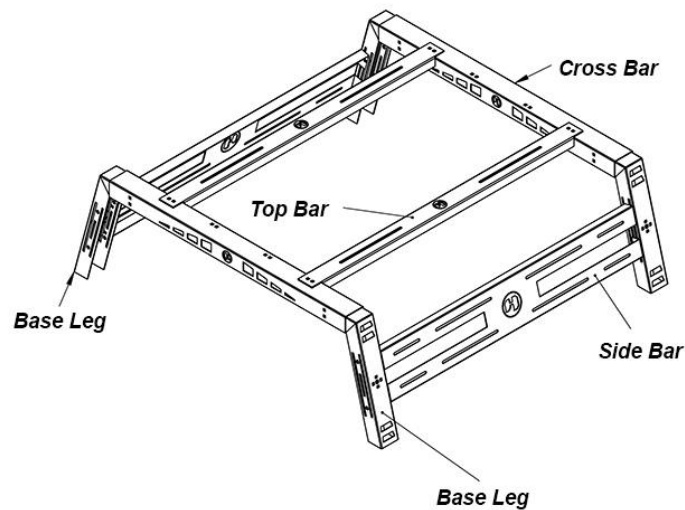

ASSEMBLY

- Start to assemble the bed rack with all the 32- 3/8" bolts, nut and washers included. It is recommended to assemble the rack upside down on a flat surface.
- Assemble as shown in the above diagram.
- Align the Base Legs where the two square holes of the Base Leg faces the two square holes on the other Base Leg. The Side Bar will mount to the Base Legs using these square holes.
- Do not tighten the bolts.

MOUNTING

- Once completely mounted, flip the rack over right side up.
- As the rack is heavy when completely assembled, it is recommended to use an extra set of hands for this.
- Place the rack on the tray bed.
- Position the rack on the tray bed to your desired position. It is recommended in an evenly distributed position.
- Install the 8-3/8" bolts to fix the rack to the bed.
- There are three mounting options for the bed rack and will vary with versions with and without the factory sliding bed rail. Also, there is the option for a no drill and drill installation.

- Mounting Option #1: No Drill Installation with Factory Bed Rail System

1. Slide in the mount plate bracket with two bolts into the factory rail system (you will need to remove the end caps to install this plate).
2. Line up the mount plate with the Base Legs and install the 3/8"-16 lock nuts and washers.



- Mounting Option #2: Drilling Option

1. Align the Bed Rack in the desired position.
2. Mark the holes on all four Base Legs on the bed rail lip using the holes on the Base Legs as a template.
3. Drill the holes using a 5/16 drill bit for the 3/8"-16 bolts. Ensure that you drill straight through the bed rail lip.
4. Assemble the bolts with the washers and lock nuts on all four Base Legs.
5. This is for versions with and without the factory bed rail system. You can mount the bed rack by drilling even though you have the factory bed rail system. In some cases, you may have to use your factory rail systems for other gear and accessories and will not have space for mounting the bed rack.



- Mounting Option #3: No Drill Option for versions without the Factory Bed Rail System
 1. Align the Bed Rack in the desired position.
 2. Place the clamp bracket behind the bed rail lip.
 3. Install the 3/8"-16 bolts, washers and lock nuts on all four Base Legs and leave loose.



- Once finished, tighten all the bolts on the bed rack and mounting supports.

Please check the bed rack and the mounting bolts on a regular basis, especially if you are going off the urban path. On a regular basis and especially if you do a lot of off-roading, inspect and tighten any loose bolts.

For Technical Support, please call (702) 560-2451 or email: info@icddesign.com

HOBBS is a brand of ICD DESIGN, LLC.

2620 Regatta Drive, Suite 102, Las Vegas, Nevada 89128, USA

Tel: (702) 560-2451 Email: info@icddesign.com Website: www.icddesign.com
