



American Made = American Jobs

**IRON CROSS
AUTOMOTIVE INC.**

GP-9481

**2020 JEEP GLADIATOR
SIDE ARM STEPS**

www.ironcrossautomotive.com

Installation Instructions

BRACKET LIST

- 4 brackets with 1 notch (2 Passenger & 2 Driver)
- 2 brackets with 2 notches (1 Passenger & 1 Driver)
- 2 brackets with no notch (1 Passenger & 1 Driver)

HARDWARE LIST

- 8mm x 25mm Bolts - 8
- 5/16" Carriage Bolts - 8
- 5/16" x 1" Bolts - 16
- 5/16" Flat Washers - 16
- 5/16" Lock Washers - 16
- 5/16" Flange Nuts - 24
- Bracket Clamps - 8

Bracket Installation

1. Align your brackets with corresponding mounting locations

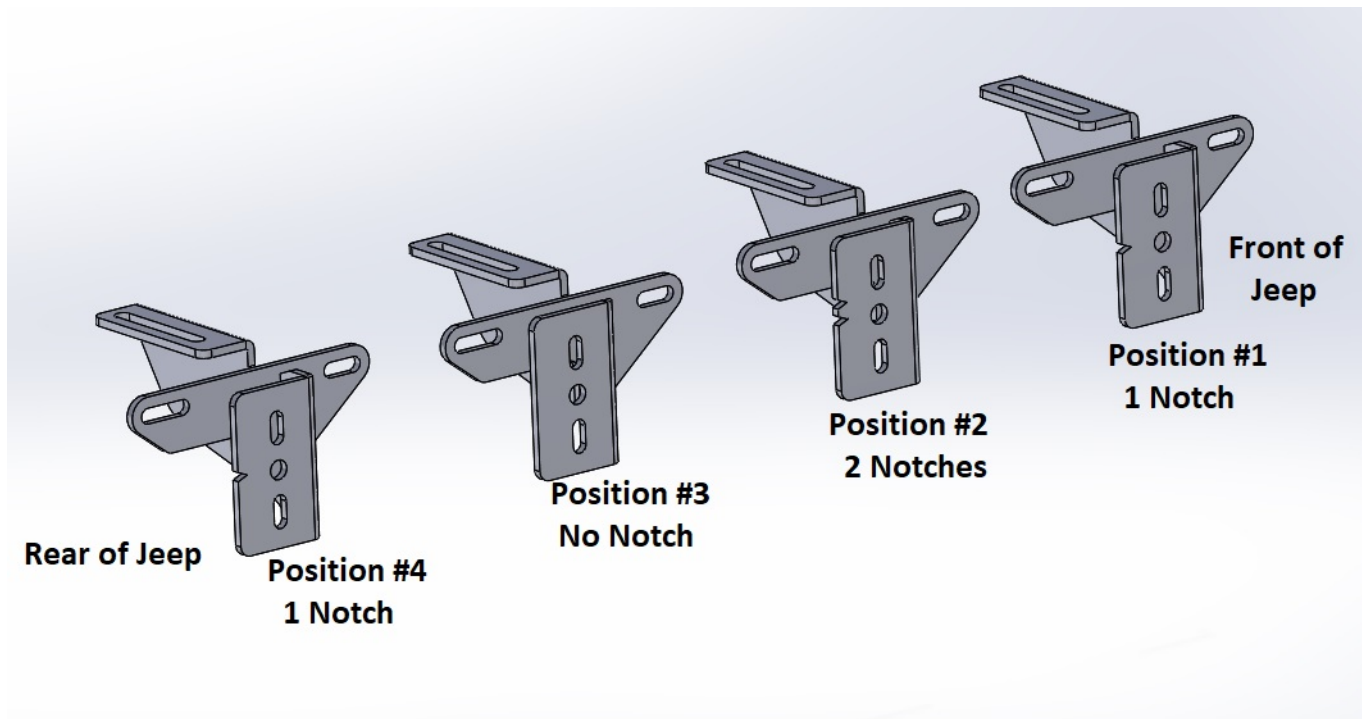

Bracket Installation Continued...

2) Attach the brackets to the body. Use the 8mm bolt, lock washer and flat washer. Thread into the floorboard. (The 8mm bolts will be stamped 8.8 on the head). **Fig 3.**

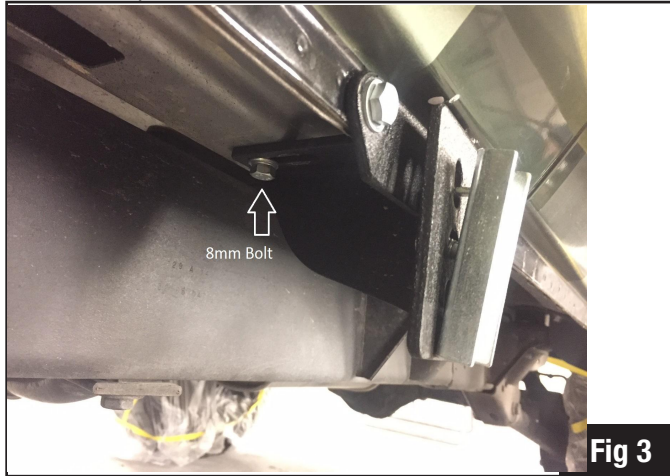

3) Use (2) 5/16" bolts, flat washers, lock washers, and nuts to attach the bracket to the pinch weld as shown in **Fig 4.**

4) Tighten brackets to the body at this time to 18 ft/lbs.

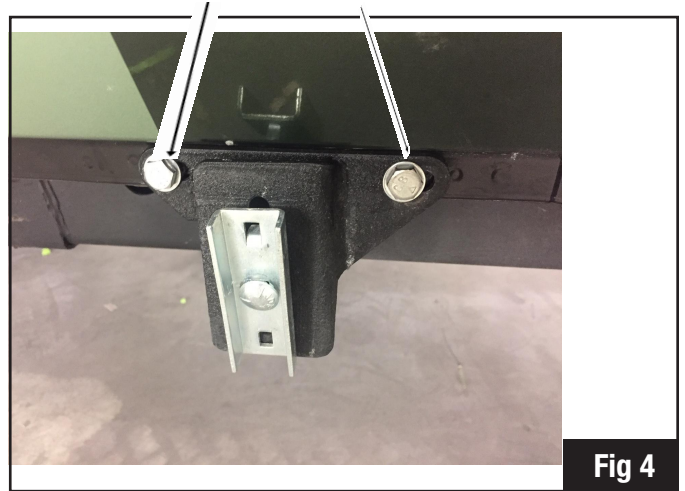

Side Arm Step Installation

1. Install 5/16" carriage bolt and "bracket clamp" to each bracket. Fig. 5
2. Carefully place sidearm step over bracket clamps and align so that clamp tabs are in between step channel. Begin to hand tighten 5/16" flange nuts while making sure bracket clamp tabs are aligning to the bracket holes.
3. Slide Side Arm Step front to rear and align and tighten all 5/16" flange nuts for final install.

Fig. 5

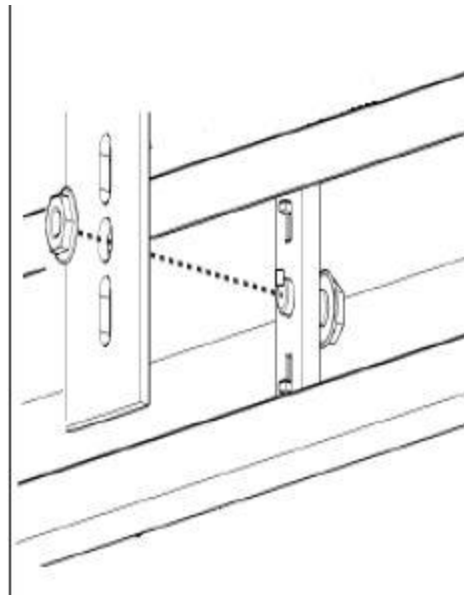

IRON CROSS AUTOMOTIVE

4942 E. 66th Street North,
Tulsa, OK 74117

www.ironcrossautomotive.com