

INSTALLATION GUIDE

PowerStep™ Xtreme

MADE IN USA

APPLICATION

Jeep Wrangler JL 4Dr

2018 - 2019

AMP Part

78132-01A

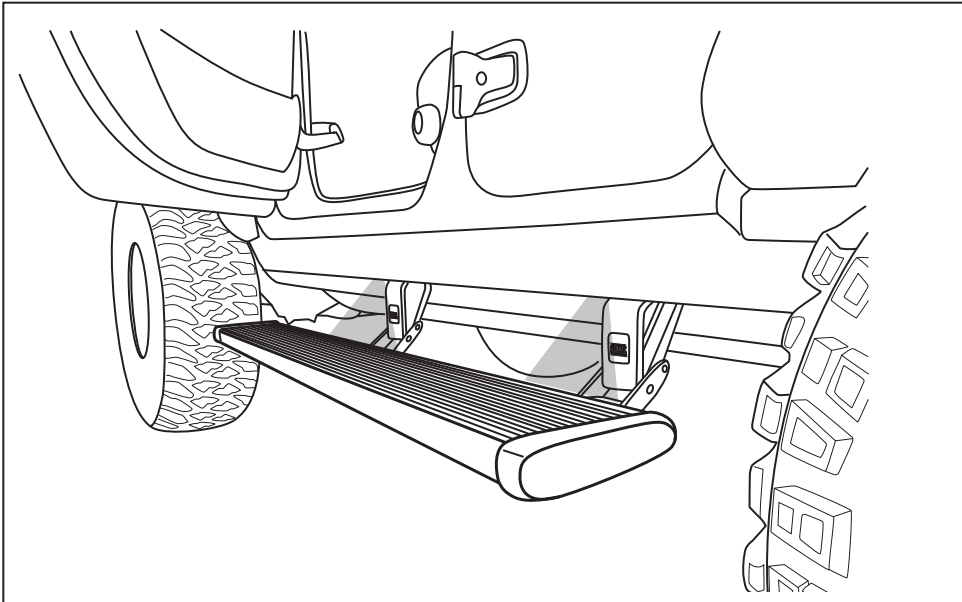

INSTALLATION TIME

3-5 Hours

Professional installation recommended

SKILL LEVEL



4= Experienced

TOOLS REQUIRED

- Safety goggles
- Measuring tape
- 10 mm socket
- 13 mm socket
- 1/2" socket
- Ratchet wrench and extension
- Wire crimpers
- Wire stripper / cutter
- 3/16" hex key wrench (allen wrench)
- 4mm hex key wrench (allen wrench)
- Electrical tape
- Weather proof caulking (silicone sealer)
- Silicone spray

WARRANTY

5-Year Limited Warranty

AMP RESEARCH TECH SUPPORT 1-888-983-2204 (Press 2) Monday - Friday, 7:00 AM - 5:00 PM PST

Invented, engineered and manufactured exclusively by AMP Research in the USA. May be covered by one of the following patents: 6,641,158; 6,830,257; 6,834,875; 6,938,909; 7,055,839; 7,380,807; 7,398,985; 7,584,975 ©2012 AMP Research. All rights reserved. Printed in USA.

EXPLODED VIEW

- Motor
- Hex Head Bolt

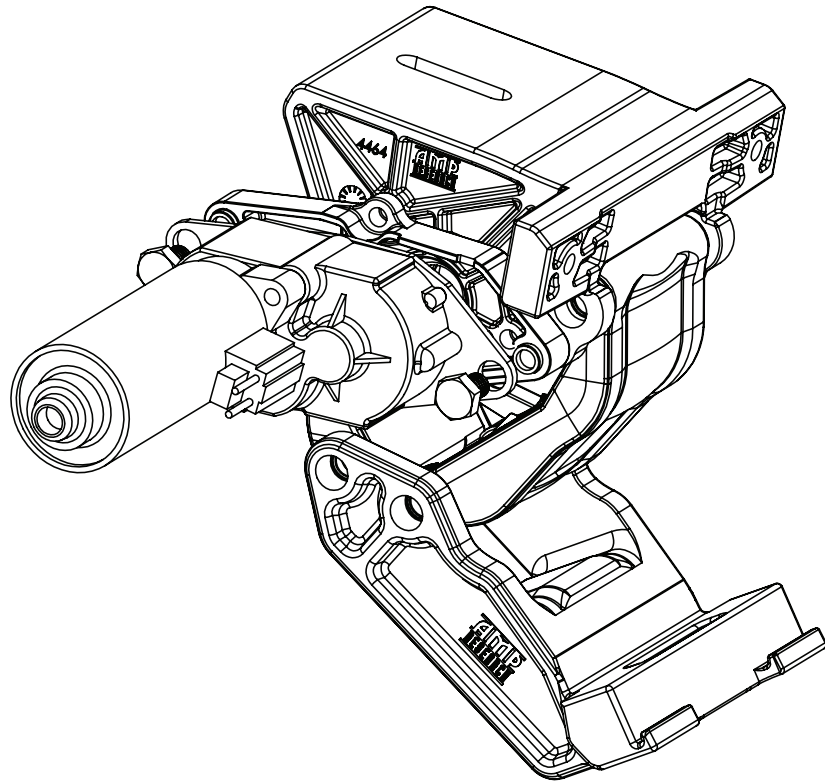

CAUTION: HANDLE WITH CARE.

To ensure our customers receive all components with full integrity, we pack the motors separate from their linkage assemblies. This requires that the installer position and fasten the motor before continuing with the install. Please follow the instructions below and handle the assembly carefully.

CAUTION: Dropping the assembly or any excessive impact MAY cause damage to the motor.

Instructions:

1. Position the gear cover in place as shown if not already in place.
2. Seat motor into position on the three mounting bosses. This may require an adjustment of the gear by moving the swing arms.
3. After seating into place, fasten the motor with the three motor mount screws with 4mm Hex Head. Tighten screws to 36 in-lbs (4N-m). **Do not over torque.**

- End cap left (x1)
- End cap right (x1)
- T-nut insert (x2)
- Socket cap screw (x2)
- Nut plate (x2)

① x2
Step assembly

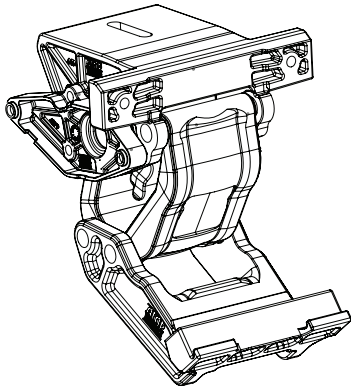
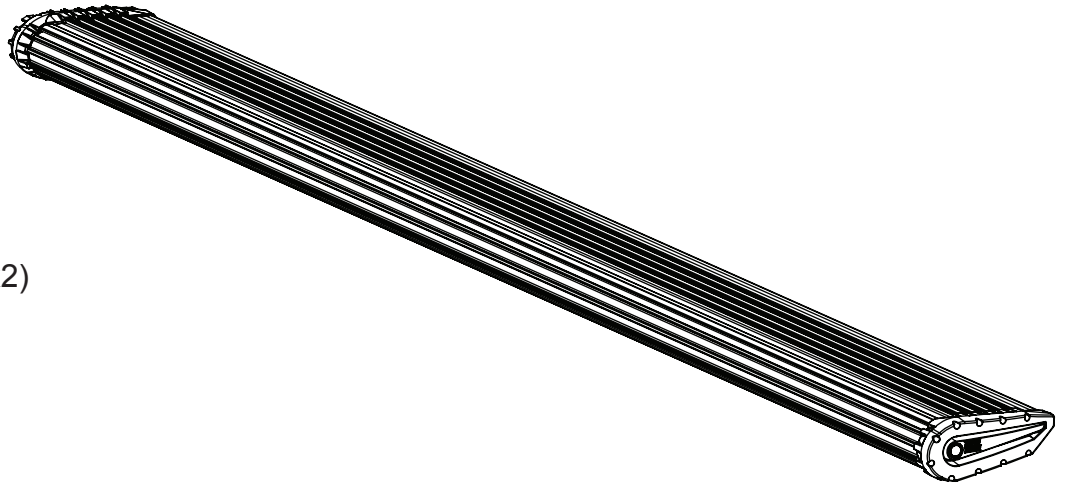

② x2
Motor Linkage assembly
Driver

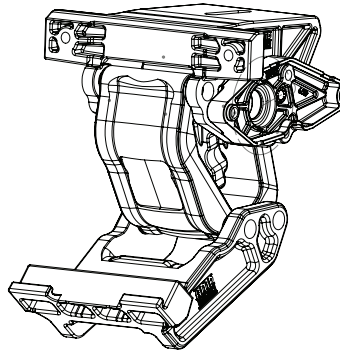

③ x2
Motor Linkage assembly
Passenger

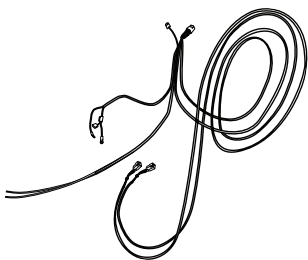

④
Wire harness

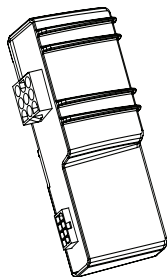

⑤
Controller XTA



⑥ x4
Posi Tap

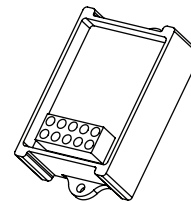

⑦
Door Trigger
Module

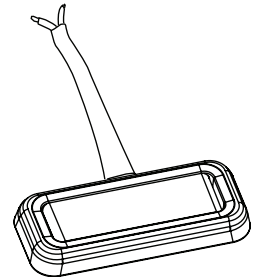

⑧ x4
LED Lamp
Module

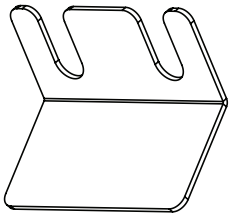

9 x4
LED Light Bracket

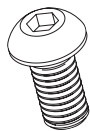

10 x8
M8 Button Head Bolt

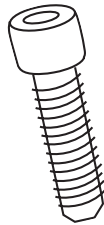

11 x8
Socket Cap Screw

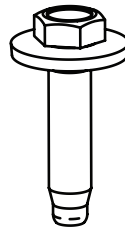

12 x4
M8 Hex Bolt w
Conical washer



13 x8
Washer

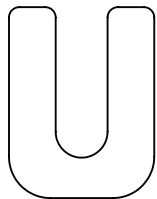

14 x2
Shim Spacer

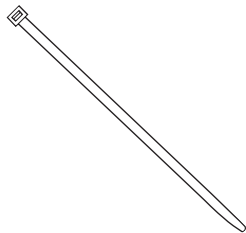

15 x20
Cable tie (7")

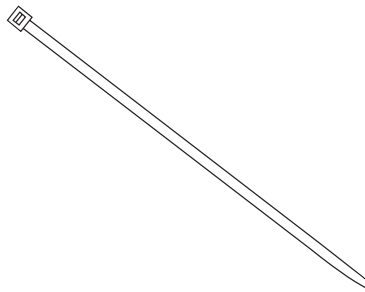

16 x2
Cable tie (11")

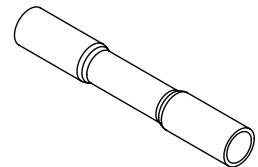

17 x11
Butt Connector

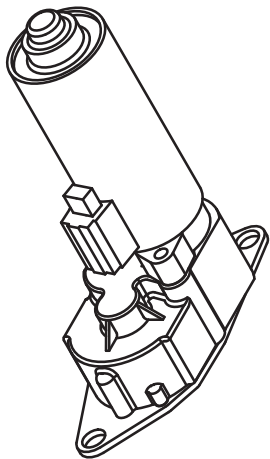

18 x4
CRH Motor



19 x12
Cinch Fastener

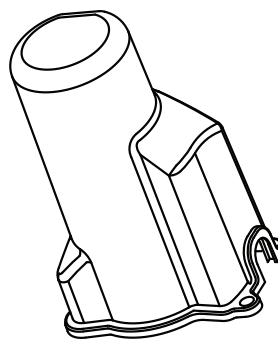

20 x4
Motor Cover

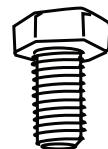

21 x8
M8 Head Hex Bolt

Install Rear Drive Linkage: Locate rear most mounting hole set. Using supplied button head screws(10) and washers(13) assemble linkage to pinch weld. Before tightening, slide Light mounting bracket(9) in forward mounting hole. Next use supplied hex bolt with conical washer(13) through bottom threaded insert in body. Torque fasteners to 16 ft-lbs (22N-m). Repeat linkage installation for passenger side.

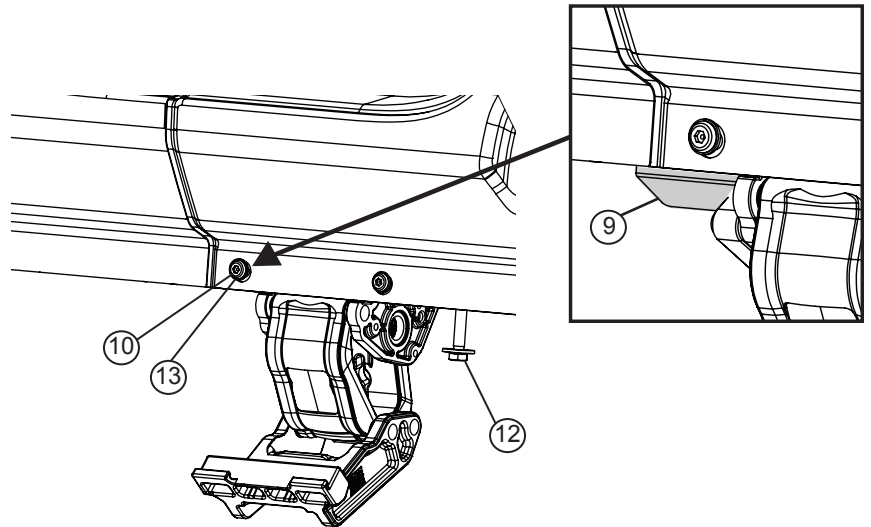

1

Install Front Drive Linkage: Locate next set of mounting holes forward. Note drive linkage with motor mount facing towards front of vehicle. . Using supplied button head screws(10) and washers(13) assemble linkage to pinch weld. Before tightening, slide Light mounting bracket(9) in Rearward mounting hole. Next use supplied hex bolt with conical washer(12) and shim (14) through bottom threaded insert in body. Torque fasteners to 16 ft-lbs (22N-m). Repeat linkage installation on passenger side.

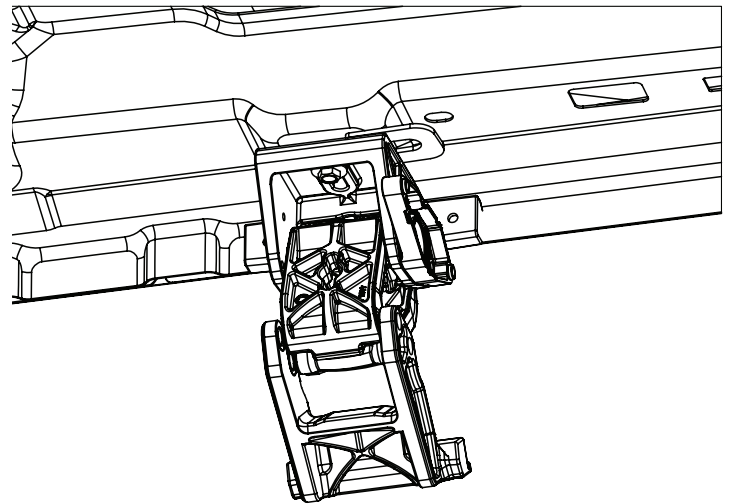

2

Mount step extrusion to linkage assemblies. Line up T nuts in step assembly with slots in lower mounts of linkage assemblies. Fasten loosely to allow for adjustments. Line up step extrusion with rear fender well. Tighten and torque 4 socket cap screws(11) with 3/16" allen wrench. Torque to 10 ft-lbs. (13.5N-m)

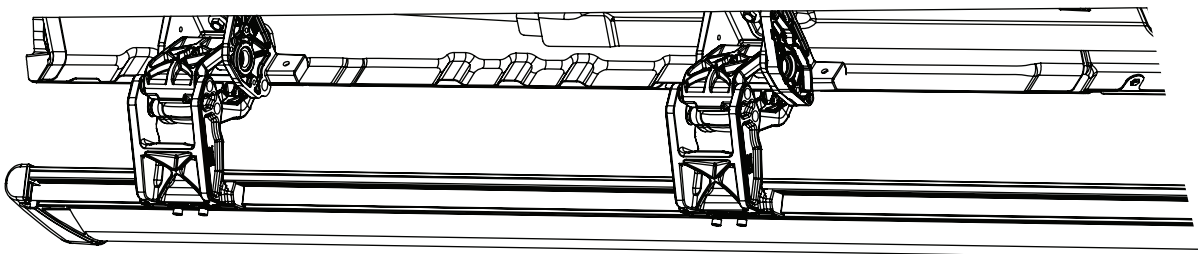

3

Slide motor assembly onto drive shaft and mounting bosses of driving linkage assembly. Use supplied M8 bolts. Torque to 8 ft-lbs(11N-m)

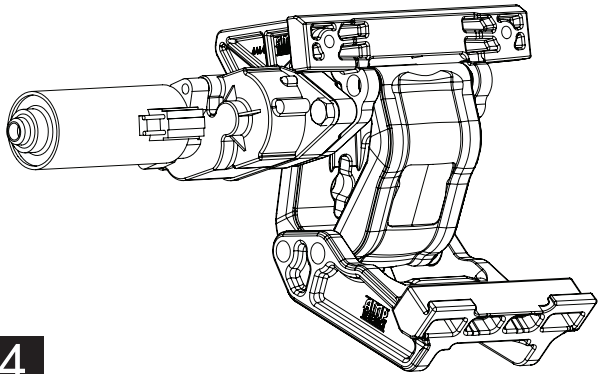

4

Remove fuses from Power Step Wire Harness.

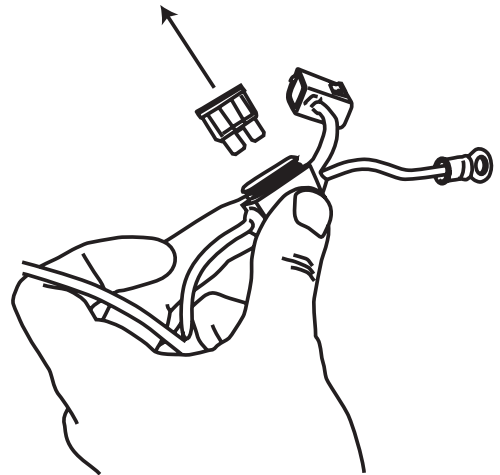

5

Prepare large tie-wraps for mounting Power Step Controller. Loosely loop tie-wraps around large bundle of wires behind battery in engine compartment. Insert controller into tie-wrap loops and cinch down securely. The tie-wraps should cinch down into channels on controller surface. Connect power leads from Controller, Red to positive battery terminal and Black to the vehicle body ground as shown.

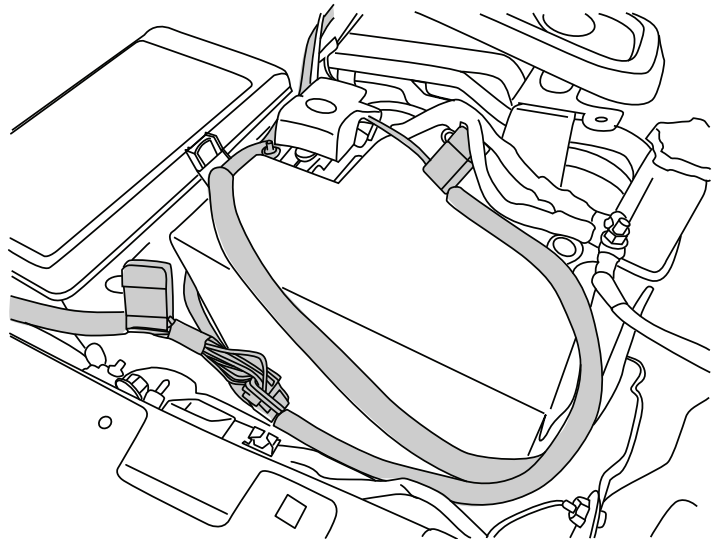

6

Splice Power Step trigger wires into the Door Ajar wires with provided Posi-Tap™ splicers. The Power Step trigger wires color coordinate with the factory Door Ajar wires. Follow the steps below to correctly splice wires.

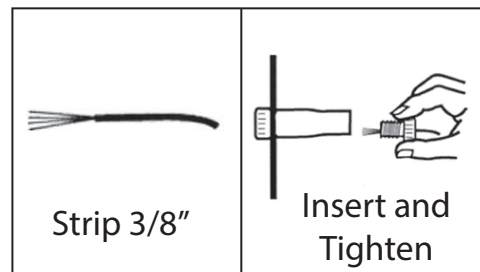
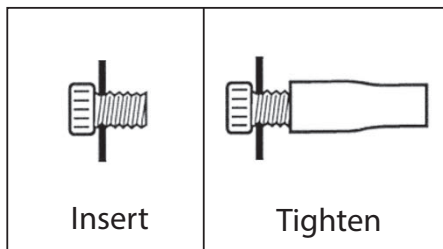

7

Route the two Wire Harness legs down over the wheel wells toward Motor Linkages, long leg across to the driver side. Secure harness with tie wraps.

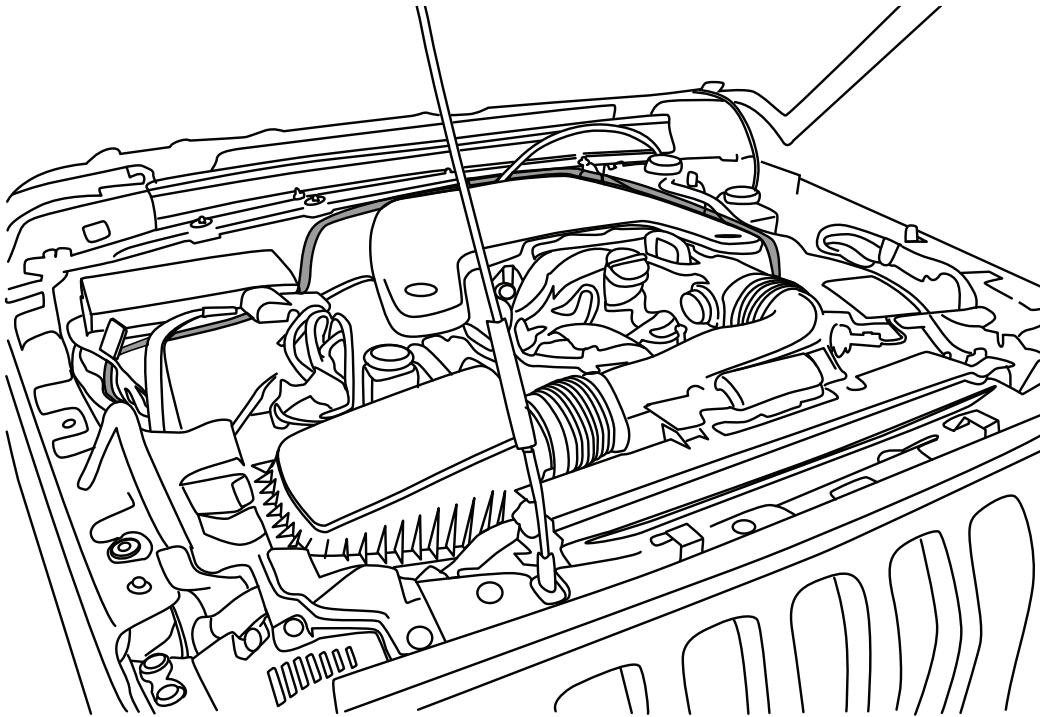

8

Remove sill plate cover. Remove grommet under floor and route trigger wires and power wire thru grommet.

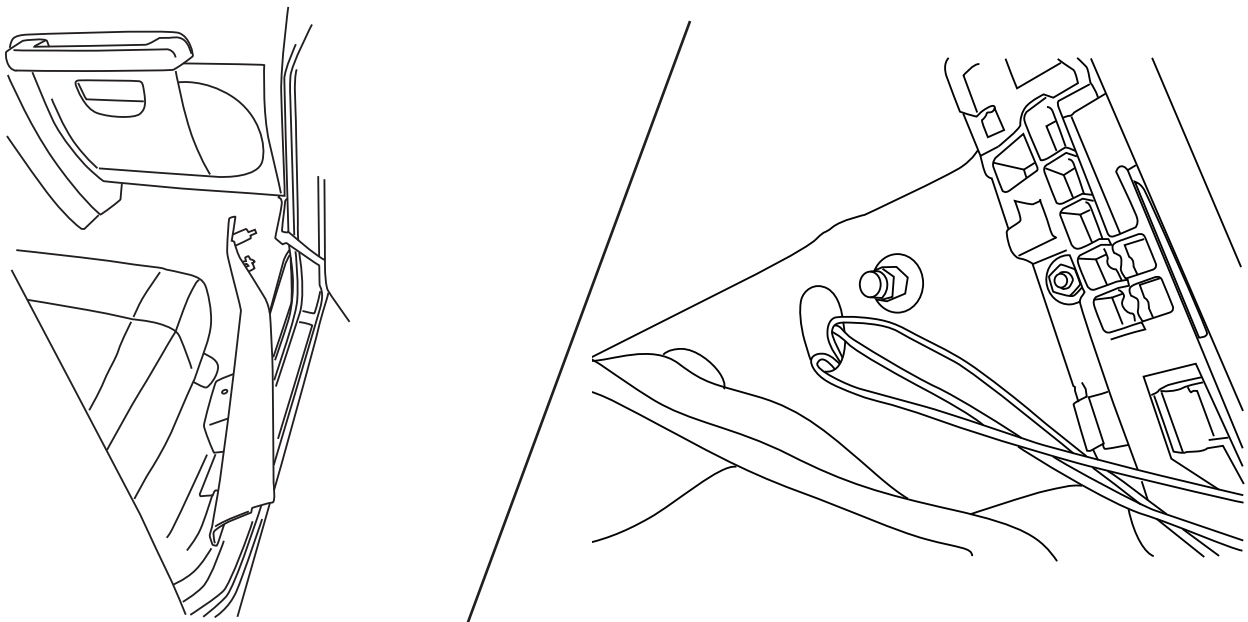

9

Mount door trigger module to wire harness in kick panel area. Using a 10mm socket remove ground lug and connect ground to body. Using supplied butt connectors connect red wire on harness to red wire (Pin1) on module. Next connect Purple with black stripe wire on harness to purple with black stripe from module (pin 6). Lastly connect Purple from harness to purple on module (Pin 7). See next step for trigger wire assembly.

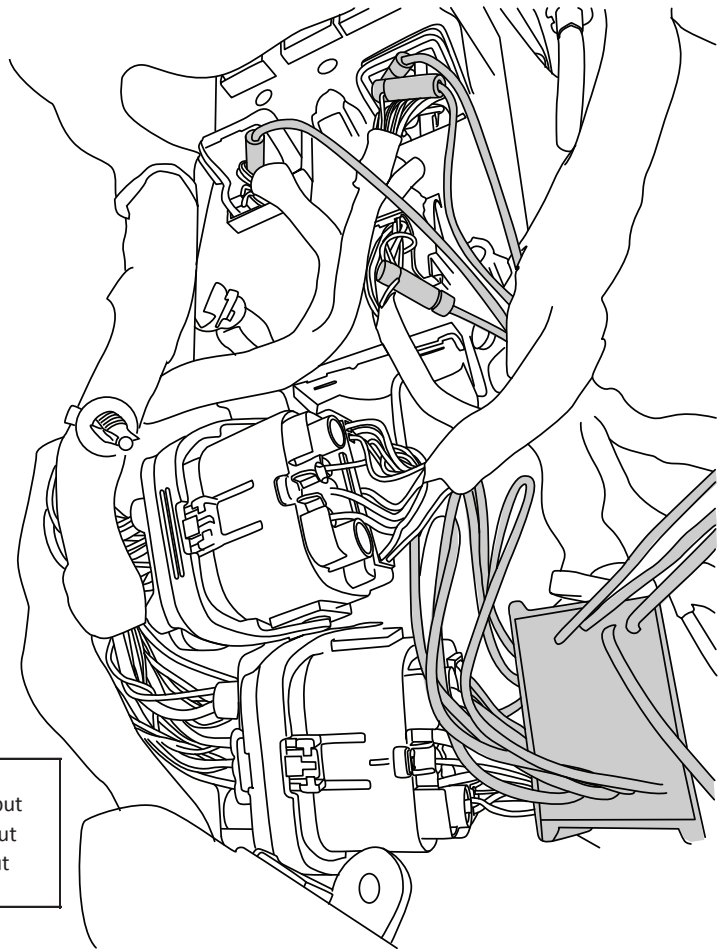

Description	Wire Color	Pin locations		Wire Color	Description
Positive Supply	Red	1	6	PRP/BLK	Driver Side Output
Ground	BLK	2	7	PRP	Passenger Side Output
Driver Front Input	PRP	3	8	WHT	Passenger Front Input
Driver Rear Input	GRY	4	9	YEL	Passenger Rear Input
Not Used	-	5	10	-	Not Used

10

Locate the white connector panel against passenger side kick panel area. Locate three connectors as shown below and connect powerstep trigger wires as indicated in the chart. Match pin locations called out in previous step.

	Vehicle Wire Color/ Stripe Color	Pin location on Door Trigger Module	Connector color
Door Ajar Wire			
Driver Front	Violet	3	White
Pass. Front	Violet/White	8	Blue
Driver Rear	Violet/Grey	4	White
Pass. Rear	Violet/Yellow	9	Black

Note: Plug reassembly is critical. Lever Arm of plug must be rotated completely locked in the open position to engage properly!

11

AMP RESEARCH POWERSTEP™ – Jeep Wrangler JL

On driver side, run Wire Harness leg down and along underside of the vehicle floor and frame to front Drive Linkage. Connect harness to motor and secure harness with tie wraps. Route remainder of wire harness towards rear linkage assembly for LED lights. Repeat step on passenger side.

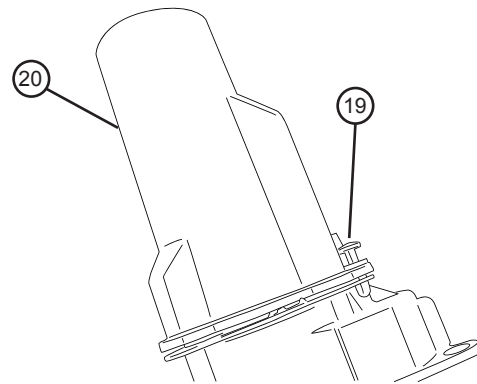
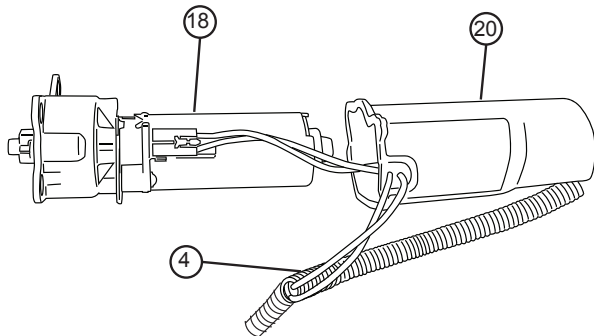

12

Affix LED lamp (8) to LED Bracket (9) as shown. Affix LED light bracket assembly to rail. Mount front light rearward of front linkage and mount rear light just forward of rear linkage.

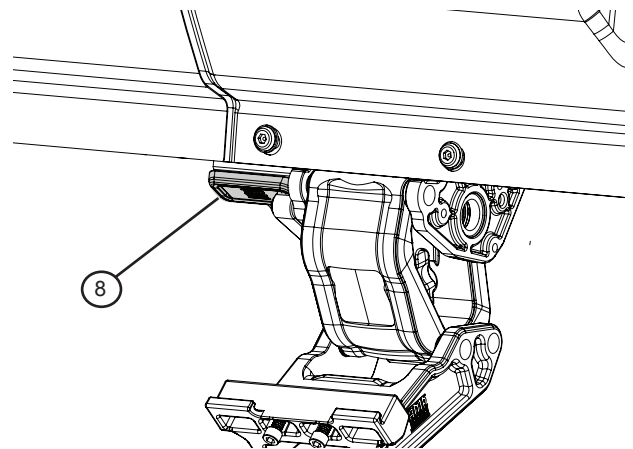
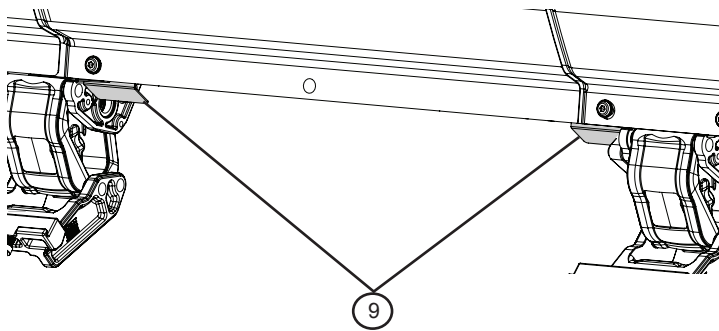

13

Using supplied butt connectors, connect the lamp wires. Red to Red, Black to Black. Once Crimped use heat gun to shrink tube. Close and wrap conduit with electrical tape. Secure all loose wires with cable ties. Pull lamp wires upward to avoid any wire snagging.

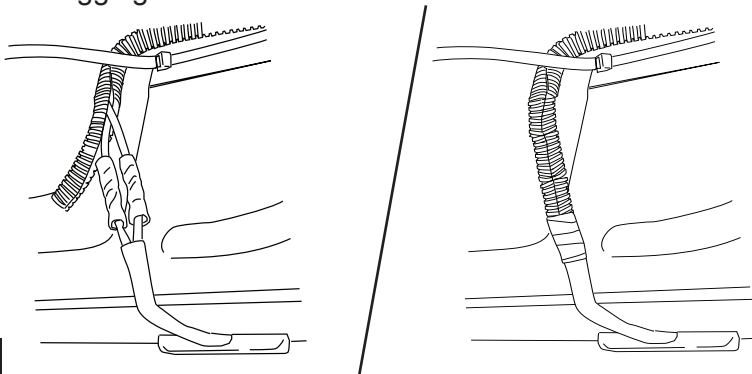

14

Reinstall Fuses from Powerstep Wire Harness.

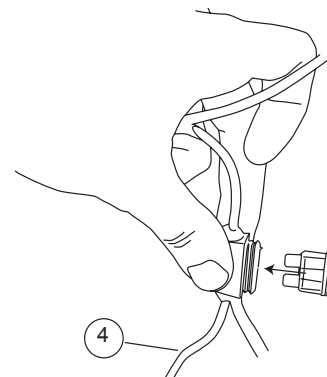

15

Check that all doors activate the Power Step and the LED Lights work when doors open and close. Reinstall any remaining trim panels.

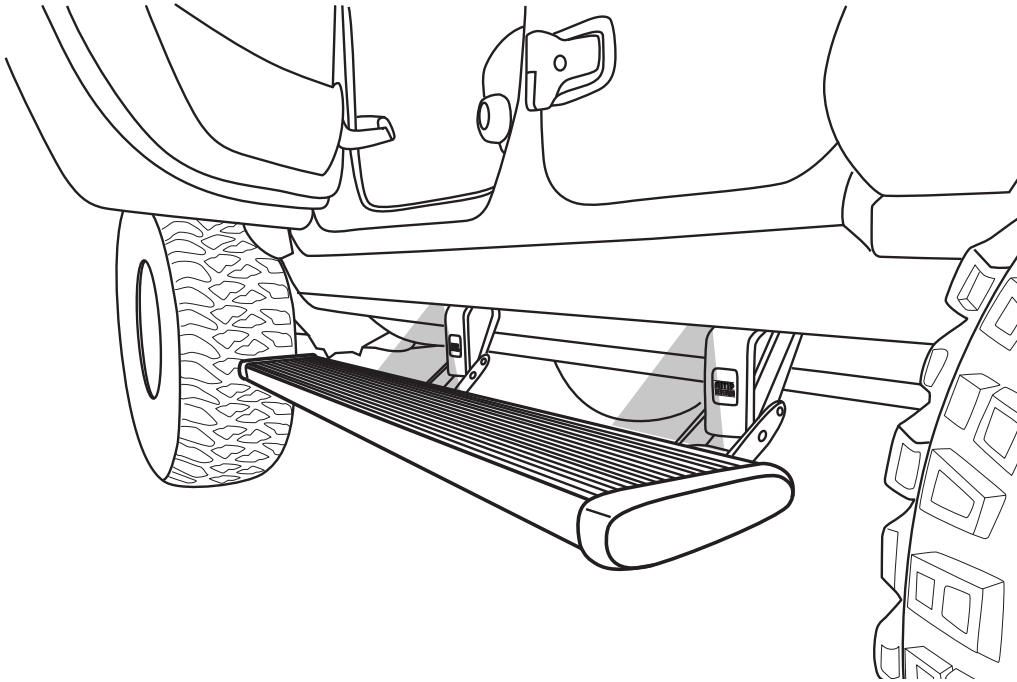

FINAL SYSTEM CHECK

Check that all doors activate the PowerStep and the LED lights work when doors open and close.

NORMAL OPERATION: When the doors open, PowerStep automatically deploys from under the vehicle. When the doors are closed, PowerStep will automatically return to the stowed/retracted position. **Note that there is a 2-second delay before the PowerStep returns to the stowed/retracted position.**

CORRECT OPERATION OF LIGHTS: All four lamps will illuminate upon opening any door of vehicle. Lamps will stay on until restowing of both Power Steps or until 5 minutes has expired with the doors open. When the lights timeout after 5 minutes, they can be reilluminated by closing and opening any door of vehicle.



Congratulations on your purchase of the genuine AMP Research PowerStep! Here's what you should know...

POWER-DEPLOYABLE RUNNING BOARDS OPERATION: AMP Research PowerStep running boards automatically move when the doors are opened to assist entering and exiting the vehicle.

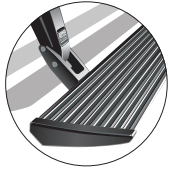

Automatic power deploy:

The running boards will extend down and out when the doors are opened.

Automatic power stow:

The running boards will return to the stowed position when the doors are closed. There will be a 2-second delay before the running boards move to the stowed position.

Automatic stop:

If an object is in the way of the moving running board, the running board will automatically stop. To reset, clear any obstruction, then simply open and close the door to resume normal operation.



Manually set in the deployed (OUT) position for access to the roof:

The running boards can be manually set in the deployed position by firmly holding the step down with your foot while at the same time closing the door. To resume normal operation, open and close the door.

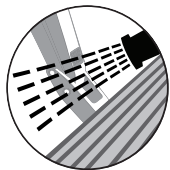

Maintenance: In adverse conditions, debris such as mud, dirt, and salt may become trapped in the running board mechanism, possibly leading to unwanted noise. If this occurs, manually set the running boards to the deployed position and flush the front and rear hinge arms with a high-pressure car wash wand.

Avoid spraying the motors directly. After washing, apply silicone spray lubricant to the hinge pivot pins. Do not apply silicone, wax or protectants like Armor All® to the running board stepping surface.

Caution! Keep hands away when the running board is in motion.

5-YEAR LIMITED WARRANTY

AMP RESEARCH warrants this product to be free from defects in material and workmanship for FIVE (5) YEARS FROM DATE OF PURCHASE, provided there has been normal use and proper maintenance. This warranty applies to the original purchaser only. All remedies under this warranty are limited to the repair replacement of the product itself, or the repair or replacement of any component part thereof, found by the factory to be defective within the time period specified. The decision to repair or replace is wholly within the discretion of the manufacturer.

This warranty specifically excludes labor. If you have a warranty claim, first you must call our factory at the number below for instructions. You must retain proof of purchase and submit a copy with any items returned for warranty work. Upon completion of warranty work, if any, we will return the repaired or replaced item or items to you freight prepaid. Damage to our products caused by accidents, fire, vandalism, negligence, misinstallation, misuse, Acts of God, or by defective parts not manufactured by us, is not covered under this warranty.

ANY IMPLIED WARRANTIES OF MERCHANTABILITY AND/OR FITNESS FOR A PARTICULAR PURPOSE CREATED HEREBY ARE LIMITED IN DURATION TO THE SAME DURATION AND SCOPE AS THE EXPRESS WRITTEN WARRANTY. OUR COMPANY SHALL NOT BE LIABLE FOR ANY INCIDENTAL OR CONSEQUENTIAL DAMAGE.

Some states do not allow limitations on how long an implied warranty lasts, or the exclusion or limitation of incidental or consequential damages, so the above limitations or exclusions may not apply to you. This warranty gives you specific legal rights, and you may also have other rights that vary from state to state.

FOR WARRANTY ISSUES WITH THIS PRODUCT PLEASE CALL AMP RESEARCH CUSTOMER SERVICE 1-888-983-2204

WARNING

Be sure to read and precisely follow the provided instructions when installing this product. Failure to do so could place the vehicle occupants in a potentially dangerous situation. After installing or reinstalling, re-check to insure that the product is properly installed.