



**BLACK-OPS SERIES**

**JK/JL/JT**

JEEP JK / JL / JT  
FRONT BUMPER



**\*VERIFY YOU HAVE ALL THE COMPONENTS BEFORE STARTING THE INSTALLATION. REFER TO THE ENGINEERING DRAWINGS AT THE END OF THIS DOCUMENT FOR A COMPLETE PARTS LIST\***

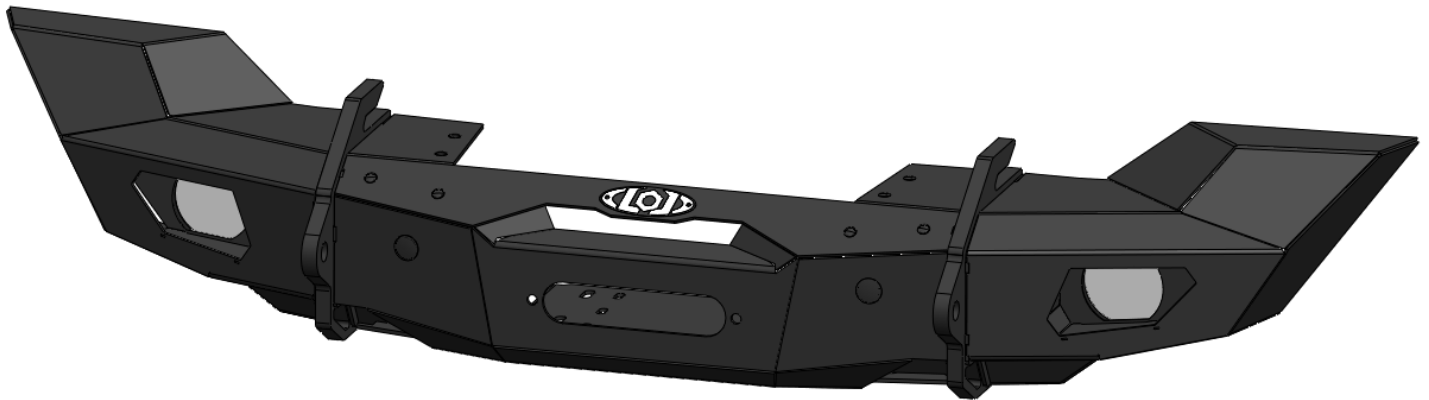

## Installing Frame Mounts and Bumper Center:

Begin by removing the factory front bumper from your Jeep.

If your bumper has fog lights, you will want to remove the wiring harness to install in your new bumper.



If you purchased the LOD Frame Tie In Brackets, you will want to install these now while installing your Front Bumper Frame Mounts.

Next install your Frame Mounts using the the  $\text{\O}7/16$  bolts, nuts and washers provided. Be sure to leave these bolts a little loose so you can check the bumper fit before tightening.

Be sure your mounts have the little arrow pointing up when installed.



Passenger Side Mount

Driver Side Mount

Arrow Points UP

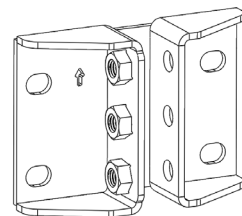
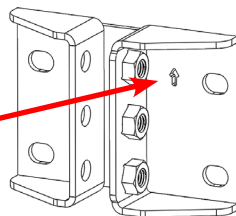

Next install the Tow Points to your Bumper Center using the  $\text{\O}1/2''$  Hex Bolts and Washers. You will be removing these bolts shortly so just snug tight for now.

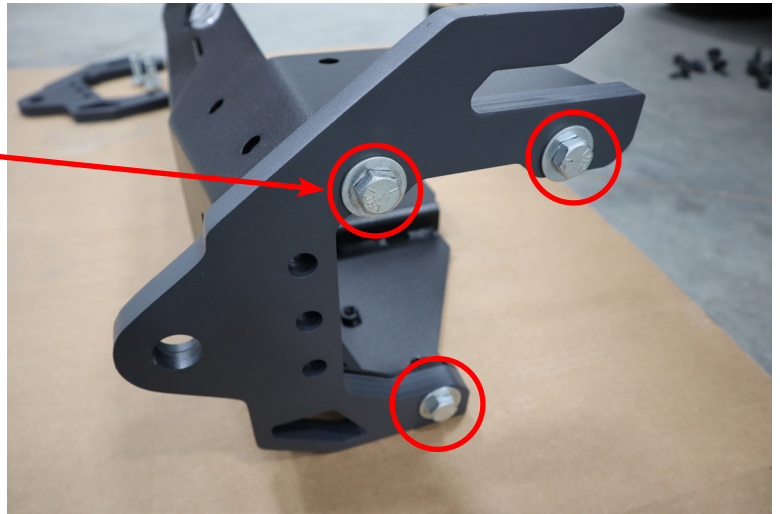

Next with a helper, place the Bumper Center (with Tow Points attached) onto your Frame Mounts as Shown. You may need to adjust the Frame Mounts slightly left or right to get the bumper to fit.

Once the Bumper Center is in position, you can leave it for a moment, it will hang there without falling. Now securely tighten the eight Frame Mount mounting bolts.

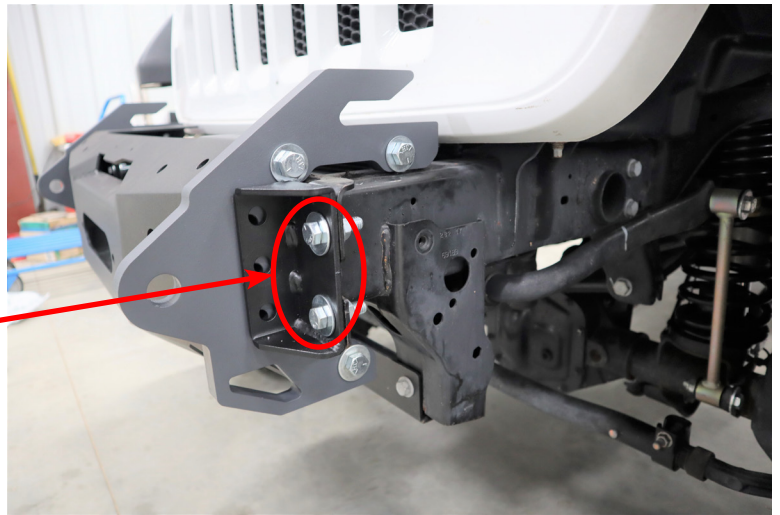

If you are not installing a winch, you can skip the sections on winch installation



## Installing Your Winch:

If your winch is small enough, you may be able to insert the winch in thru the top of the bumper while the bumper is installed on your Jeep. Larger winches like a Warn Zeon will need to be installed at the same time the bumper is installed.

With your Frame Mounts tightened securely, remove the Bumper Center by carefully sliding it back off the mounts. Place the Bumper Center onto a work surface and proceed with installing your winch.

Double check the spacing between the front frame plates vs. the length of your winch. If your winch will fit between the face plates, proceed to install your winch in the bumper as shown below. If it will not fit between the face plates, proceed to the next section for installing Warn Zeon or other large winches.

Install your winch Fairlead onto the Bumper Center first and then install your winch using the hardware provided with your winch.

Don't forget to spool the rope on your winch prior to installation. Although this can be done after install, it is a bit more difficult.

Place the winch into the Bumper Center over the 4 slotted mounting holes. Slide the winch as far forward as it will go and securely tighten the winch in place.

With a helper install the Bumper Center with winch onto the Frame Mounts as shown. It should slide in place easily without loosening the Frame Mount bolts.

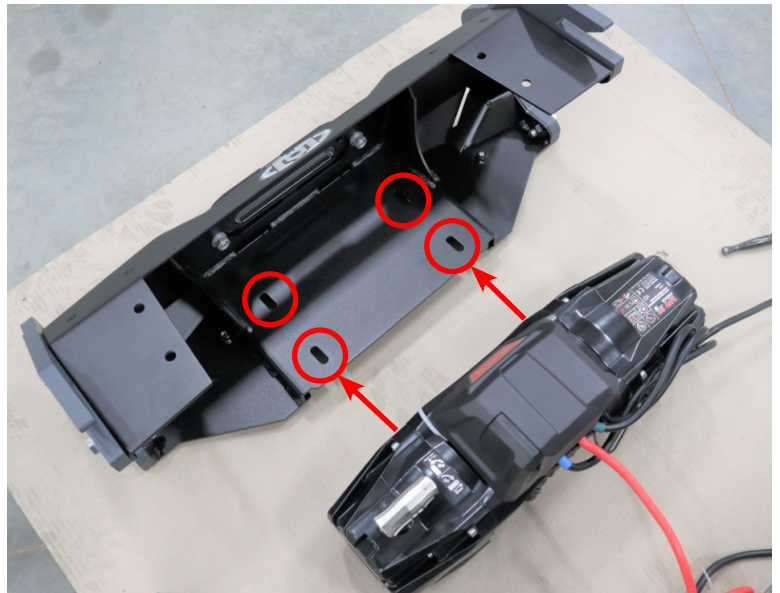

## Installing Warn Zeon or other Large Winches:

If you are installing a Warn Zeon or other winch that is too long to fit between the frame face plates, you will need to install the winch at the same time you install the bumper.

### \*\*\*Special Note\*\*\*

Be sure the 4 nuts in your winch base are installed prior to installing the winch, there is very little room to get these in after the fact. Also dont forget to install the fairlead and spool your winch rope prior to installation. Although this can be done after install but it is a little more difficult.

To do this start by placing the Bumper Center on the floor or work surface in front of your Jeep. Then place the winch into the bumper at a slight angle as shown here.

Arrange the winch power cables so they wont be in the way during the installation.



With a helper, begin installing the Bumper Center onto the Frame Mounts.

While one person holds the bumper in place, the other will maneuver the winch between the frame face plates





Position the winch behind the frame face plates as shown here before sliding the Bumper Center into the Frame Mounts.

With your helper holding the winch in position behind the frame face plates, you can now slide the Bumper Center into the Frame Mounts. It should slide in place easily without loosening the Frame Mount bolts.

Frame Face Plate

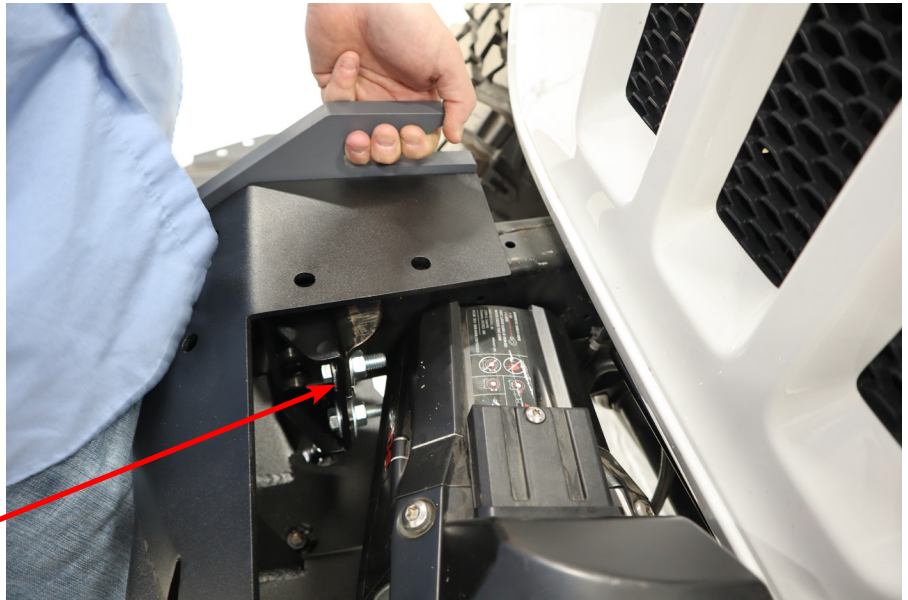

**Complete the Bumper installation before tightening your winch bolts!**

From underneath the bumper, install your winch mounting bolts and slide the winch as far forward as possible. Then securely fasten all 4 winch mounting bolts.

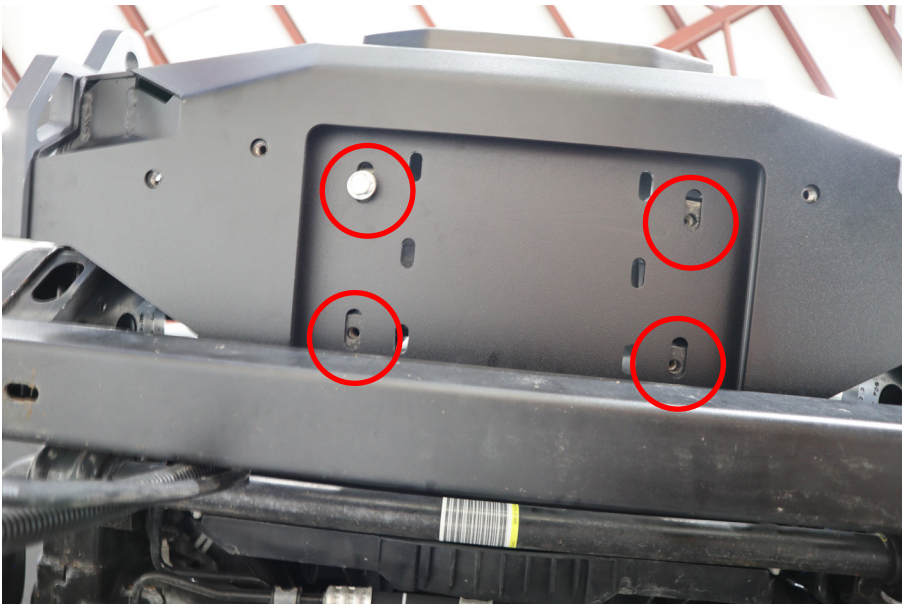

## Installing Frame Mounts and Bumper Center: Cont'd

Position the Bumper Center so that the 3 mounting holes are aligned.

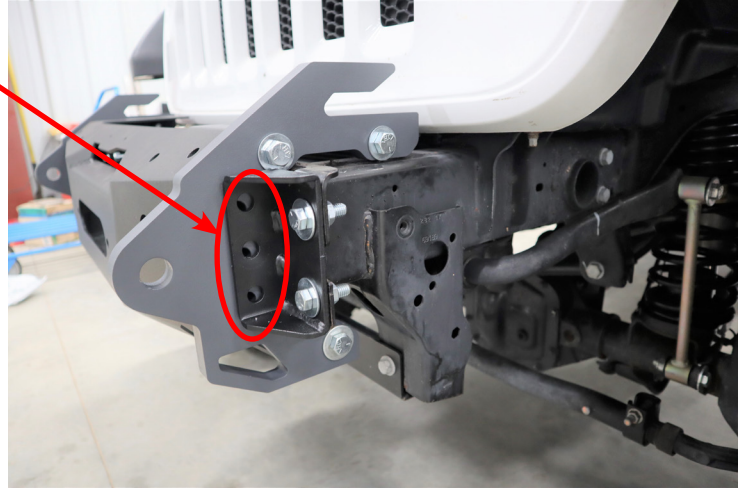

Install the  $\text{\O}1/2''$  Hex Bolts and Washers into the 3 holes on each Frame Mount and tighten securely.



With the Bumper Center now securely mounted to the Frame Mounts. Remove the original 3 Hex Bolts that were installed. These bolts will be used to install the wings.

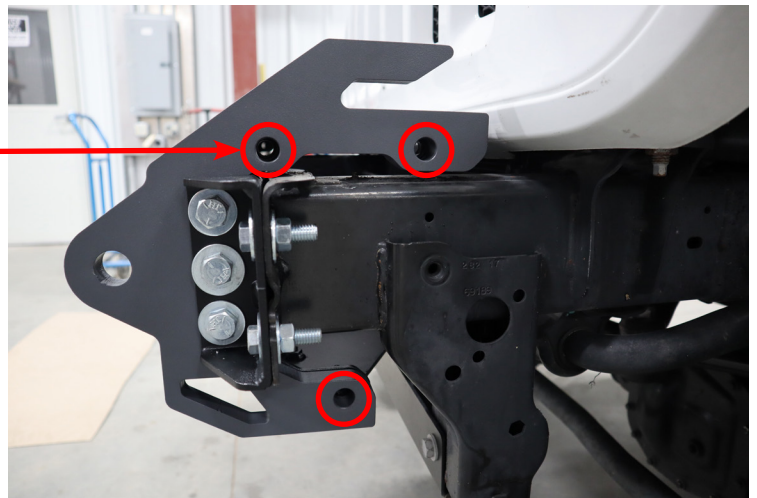



## Installing Wings:

Next install the Wings using the  $\text{\O}1/2''$  Hex Bolts and Washers that you just removed from the Tow Points on your Bumper Center.

Install all 3 hex bolts loosely. You can rotate the wing slightly on the bolts. Position as needed and tighten securely.

The inner bolt above the light pocket can be difficult to reach. We were able to easily install this bolt using a universal joint adapter and a 6" or longer extension on our 3/8" ratchet. Similar to the one pictured below.





## Installing Fog Lights:

If your stock bumper has fog lights, you can install these into your new LOD bumper using the optional "Stock Fog Light Bezel" purchased separately. There are 4 different stock OEM fog lights, refer to the diagrams below to see how your fog light will fit in your new bumper.

Or install your favorite aftermarket fog lights using the appropriate Black Ops Light Bezel. Or you can install blank bezels if you dont want to run fog lights in your bumper.

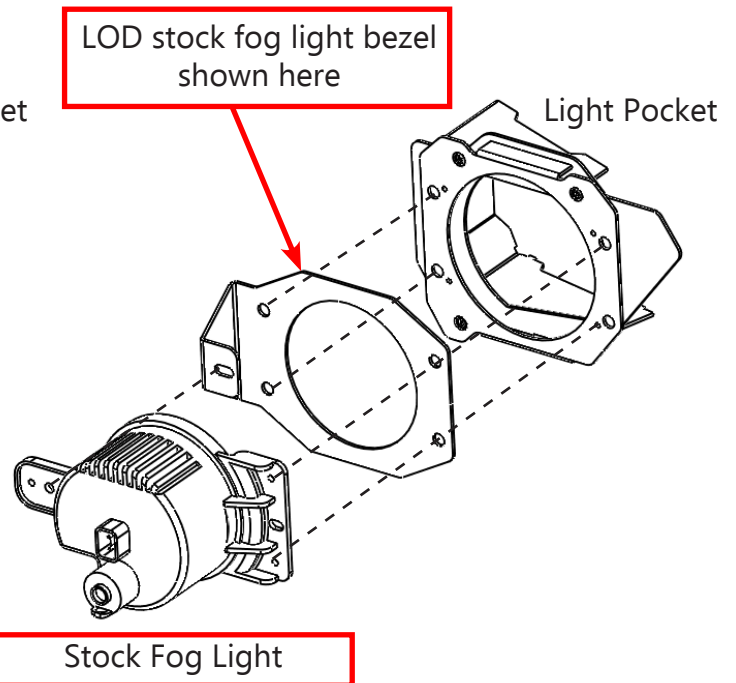
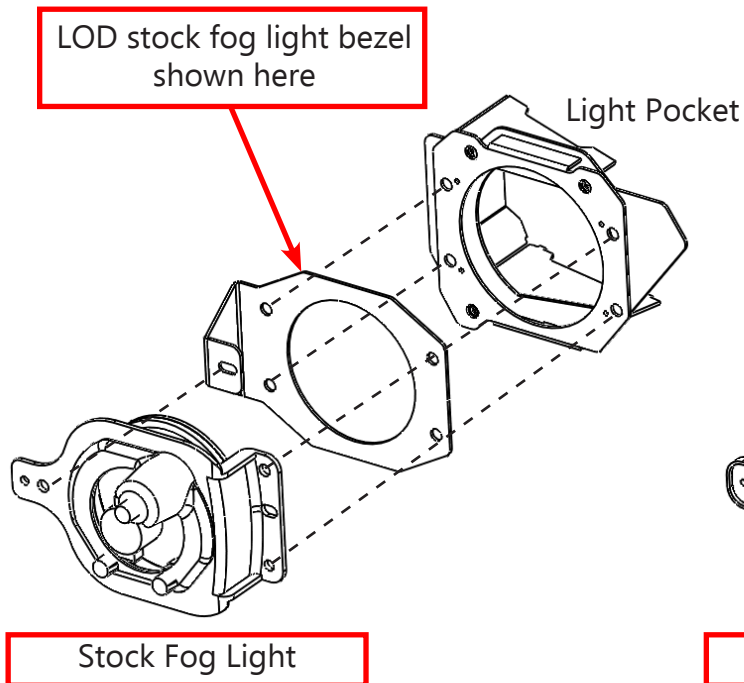

If your stock fog light looks like this one shown below with the 4 mounting ears, you will not need our optional fog light bezel. This light will mount straight to our light pocket using the 4 small self tapping screws

If your stock fog light looks like this one shown below with the 2 large mounting ears off to one side, you will **NOT** be able to install this light in your new LOD Black Ops Front Bumper.

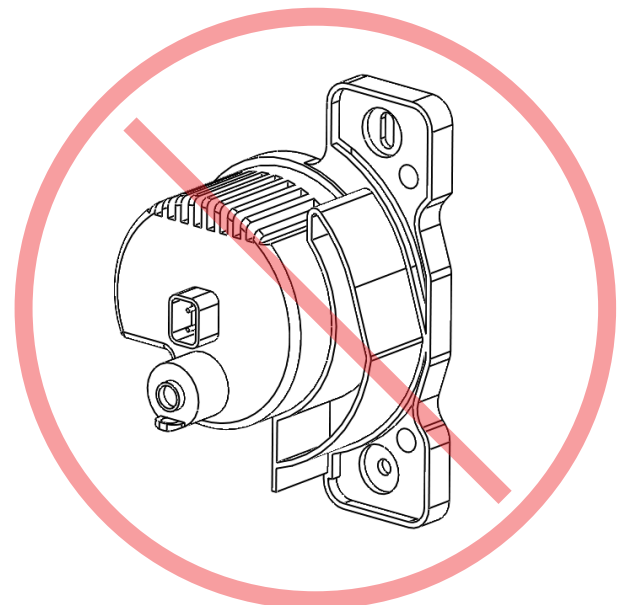
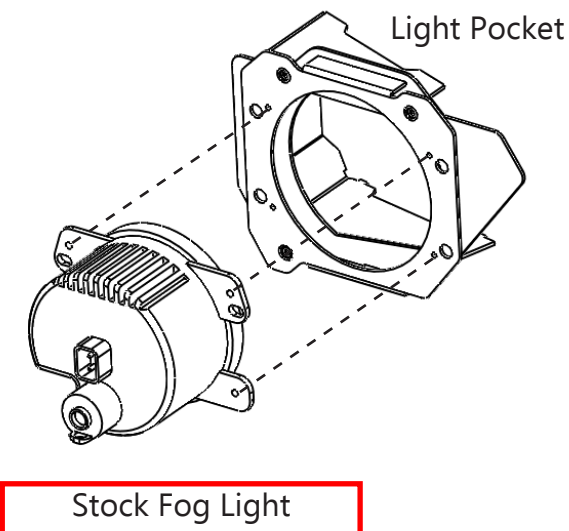

If your Halogen or LED fog lights are from the OEM Plastic bumper, you will need to drill a couple holes in the fog light flange to be able to mount into you LOD Light Bezel.

Assemble your fog light to the Fog Light Bezel using the single Button Head Screw and Washer and Nut.

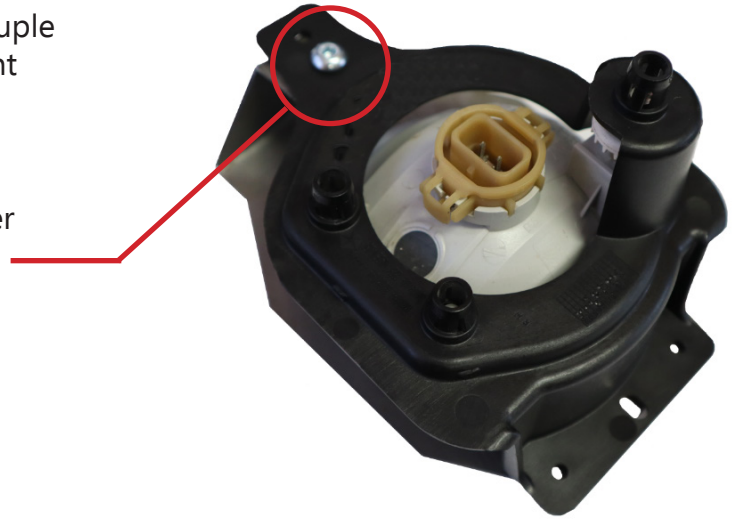

Center your fog light in the new Fog Light Bezel as shown and then mark the two mounting holes circled on the fog light flange. Drill these using a Ø1/4" drill bit.

Be careful when you drill these since the existing mounting holes in the plastic flange are not quite in the correct location.

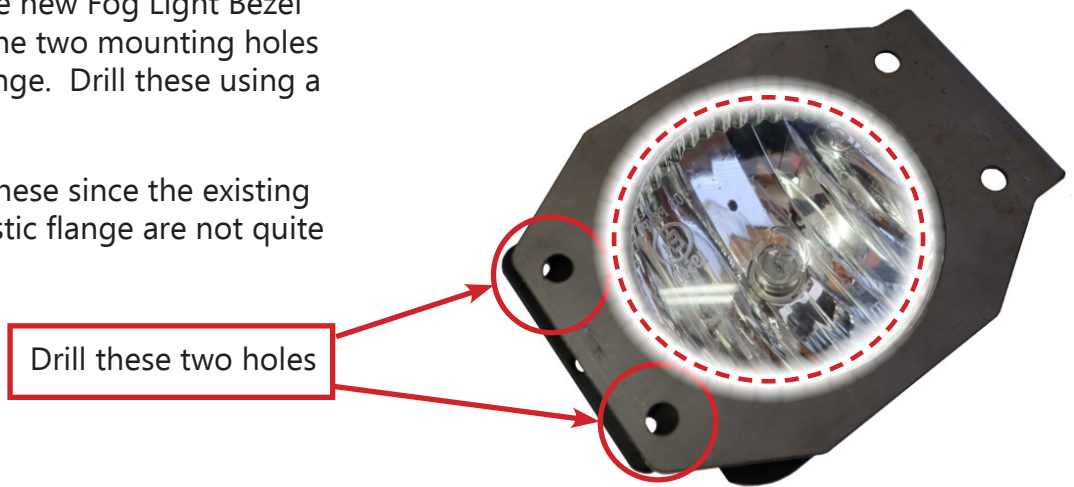

Install your bezels using the Ø1/4" Button Head Screws and Washers provided. Or the self tapping screws provided.

View of fog light bezel from inside the wing



Depending on your stock bumper configuration, you may need to lengthen your fog light wiring harness. Unwrap the sheathing to expose more length or splice in additional wire to add length where needed.



## **\*\*Maintenance\*\***

- Periodically check and re-tighten all fasteners.
- 
- Periodically check your product for scratches, dings, or rust spots which can happen over time or after heavy use. It is important to address these areas as soon as possible to prevent rust and corrosion from spreading. We recommend using Rustoleum® brand Black Semi-Gloss Protective Enamel (oil based). Apply using a foam brush by dabbing to match the powder coat texture.



ITEM NO.	PART NUMBER	DESCRIPTION	QTY.
1	4AFB2021-01	BUMPER CENTER WELDMENT	1
2	2AFB2021-32	FRONT TOW POINT	2
3	4JFB1880-04	JEEP JK/JL BUMPER MOUNT - PS	1
4	4JFB1880-05	JEEP JK/JL BUMPER MOUNT - DS	1
5	4JFB1880-03	JEEP FULL WIDTH WING - PS	1
6	4JFB1880-06	JEEP FULL WIDTH WING - DS	1
7	2AFL2000-01	BLANK LIGHT BEZEL	2
8	LOGO1001	DESTROYER LOGO - EMBOSSED	1
9	HP1004	HOLE PLUG Ø1.125"	2
10	HP1006	HOLE PLUG Ø0.50" BLACK	8
11	HB501328ZPGR5	HEX BOLT 1/2-13 X 1.75 HEX BOLT ZINC PLATE GR5	12
12	HB431424ZPGR5	HEX BOLT 7/16-14 X 1.50 HEX BOLT ZINC PLATE GR5	8
13	HN43142ZPGR5	HEX NUT 7/16-14 ZINC PLATE GR5	8
14	FW4318ZP	FLAT WASHER Ø7/16 X 1.25" ZINC PLATED	28
15	BHSCS252008ZP	BHSCS 1/4-20 X 0.50 ZINC PLATE	6
16	FW1209ZP	FLAT WASHER #12 X .56" ZINC PLATED	6
17	HH081808SDZP	HEX HEAD #8 X .50 SELF DRILLING SCREW ZINC PLATE	8

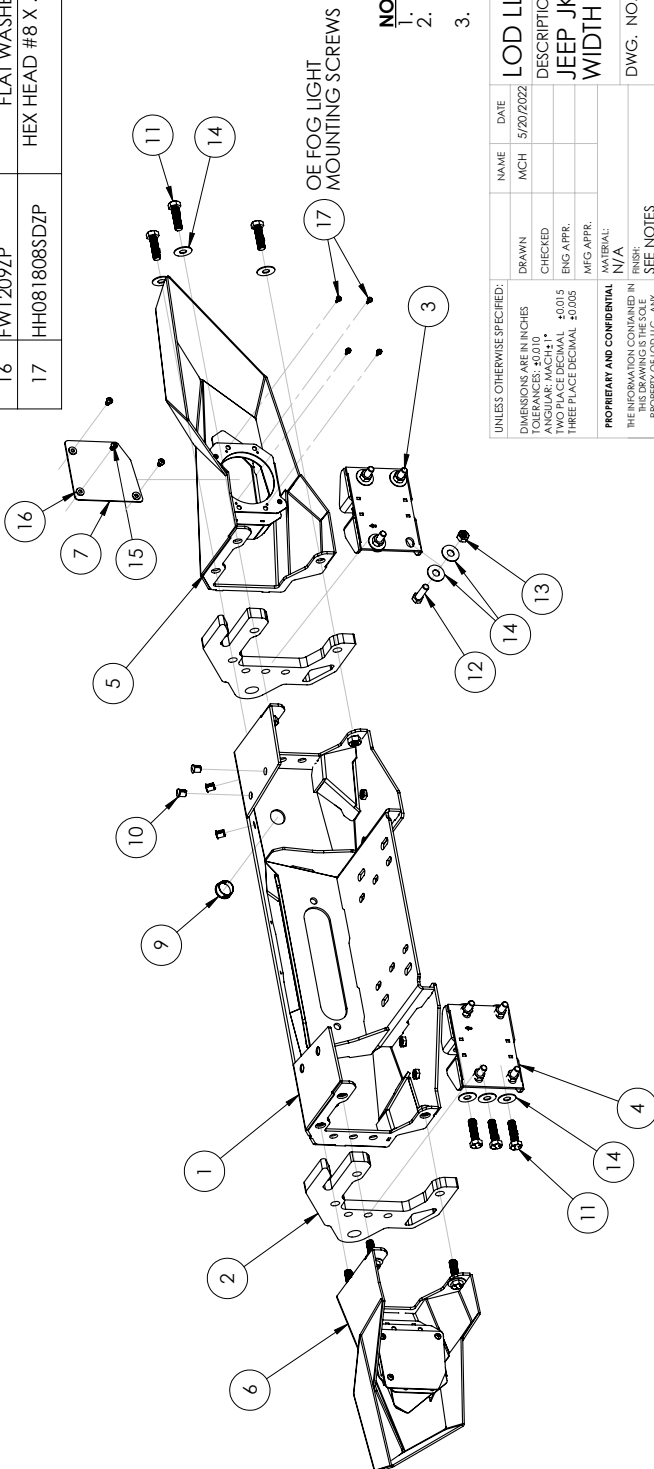
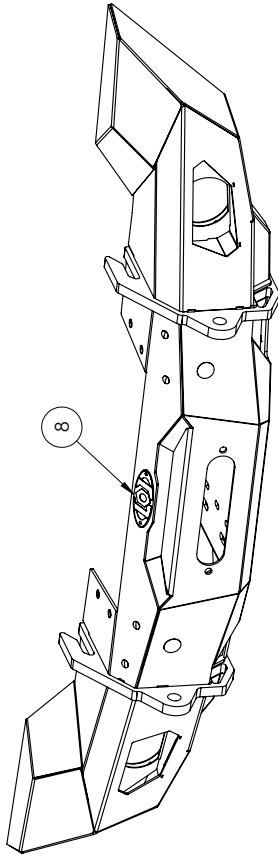

- NOTES:**
- JFB1880 = BARE STEEL OPTION
  - JFB1881 = BLACK POWDER COAT
  - WEIGHT = APPROX 88.65 LBS

UNLESS OTHERWISE SPECIFIED:		NAME	DATE
DIMENSIONS ARE IN INCHES		MCH	5/20/2022
TOLERANCES: ±0.010		DRAWN	
ANGLES: ±0.5°		CHECKED	
TWO PLACE DECIMAL ±0.015		ENG APPR.	
THREE PLACE DECIMAL ±0.005		MFG APPR.	
<b>PROPRIETARY AND CONFIDENTIAL</b>		MATERIAL:	N/A
THIS INFORMATION CONTAINED IN THIS DRAWING IS THE PROPERTY OF LOD LLC. ANY REPRODUCTION IN PART OR AS A WHOLE WITHOUT THE WRITTEN PERMISSION OF LOD LLC IS PROHIBITED.		FINISH:	SEE NOTES
		ECCO:	

LOD LLC.  
 DESCRIPTION:  
 JEEP JK/JL BLACK OPS BASE FB - FULL WIDTH

DWG. NO. JFB1880  
 JFB1881

SCALE: 1:8 SHEET SIZE: B SHEET 1 OF 1





**Jeep JK / JL / JT**  
**BLACK-OPS SERIES**  
 FRONT BUMPER - CENTER  
 SHIPPING SHEET - BOX 1

Packaged by:

\_\_\_\_\_

On:

\_\_\_\_\_

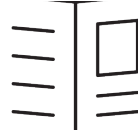

INSTRUCTION  
SHEET

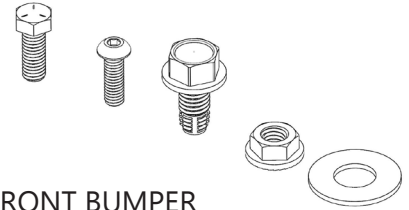

FRONT BUMPER  
CENTER BOLT KIT  
JFB1880-BK

**(x1)**



LOD LOGO  
(PACKAGED SEPERATE  
IF BUMPER IS BARE STEEL)

**(x1)**

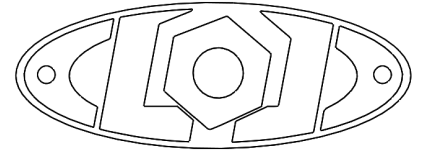

BUMPER CENTER WELDMENT  
4AFB2021-01

**(x1)**

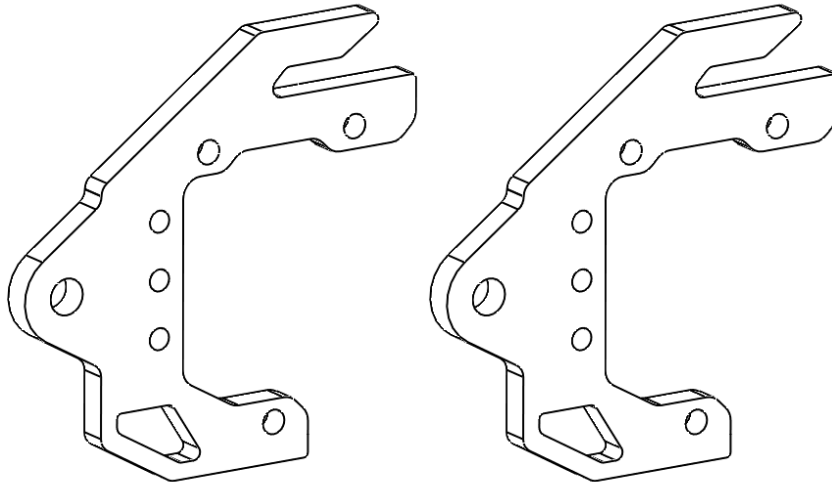
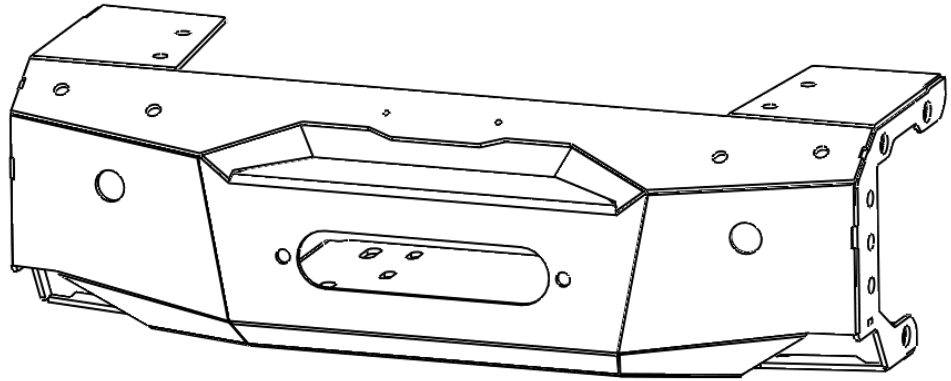

FRONT TOW POINT  
2AFB2021-32

**(x2)**



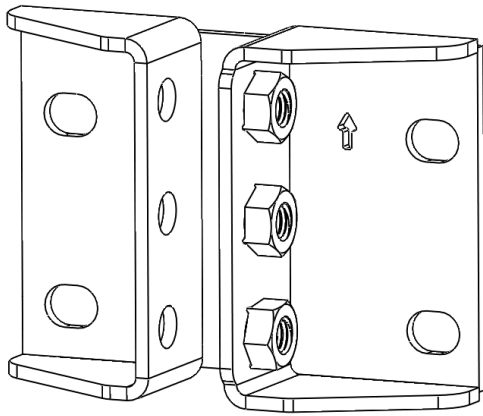

JEEP JK/JL/JT  
FRAME MOUNT - PS  
4JFB1880-04   
**(x1)**

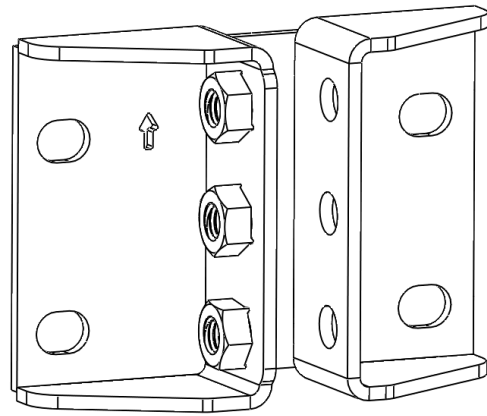

JEEP JK/JL/JT  
FRAME MOUNT - DS  
4JFB1880-05   
**(x1)**

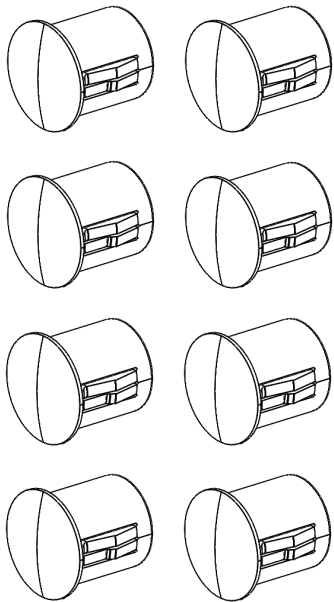

HOLE PLUG Ø0.50  
HP1006   
**(x8)**

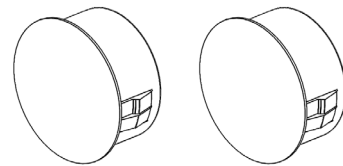

HOLE PLUG Ø1.125  
HP1004   
**(x2)**





**Jeep JK / JL / JT**  
**BLACK-OPS SERIES**  
FRONT BUMPER  
Bolt Kit

Packaged by:

\_\_\_\_\_

On:

\_\_\_\_\_

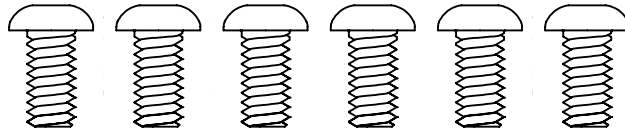

BUTTON HEAD SCREW

1/4-20 X 0.50"

(94049)



**(x6)**

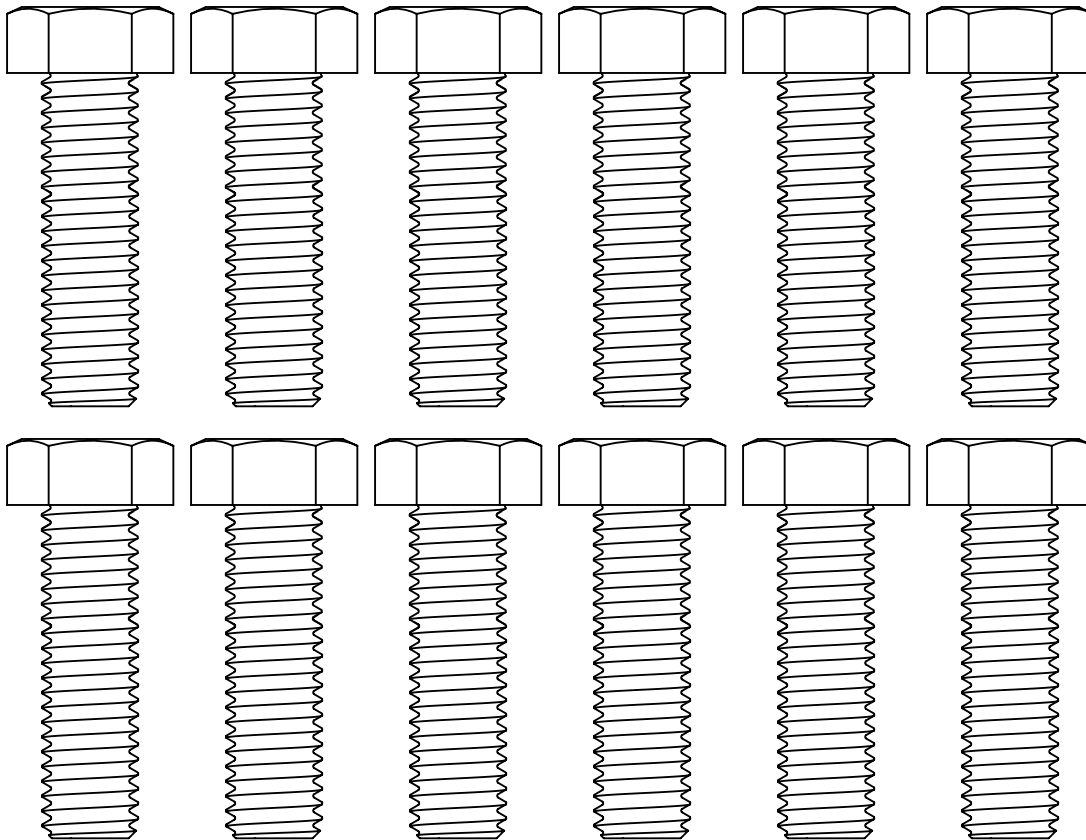

HEX BOLT 1/2-13 X 1.75"

(0137546)

**(x12)**



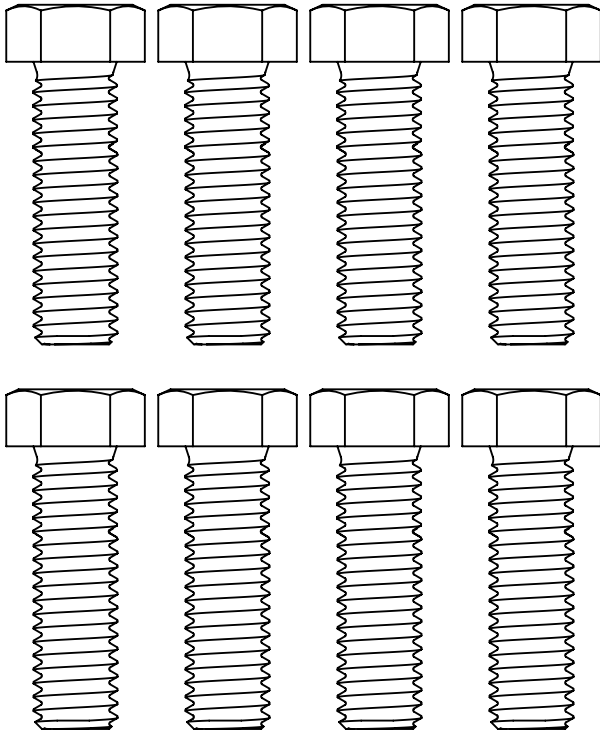

HEX BOLT 7/16-14 X 1.50"  
(13159)  
**(x8)**

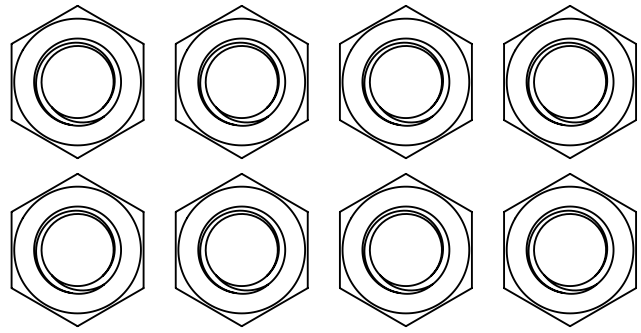

HEX NUT 7/16-14  
(36308)  
**(x8)**

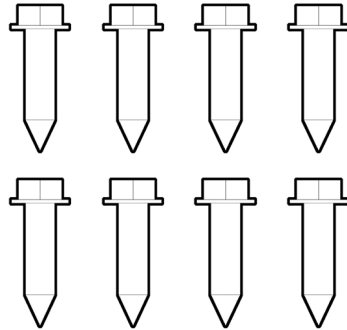

#8 SELF TAPPING SCREW  
**(x8)**

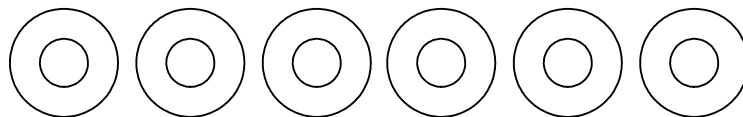

FLAT WASHER  
#12 X 0.56"  
(33076)  
**(x6)**





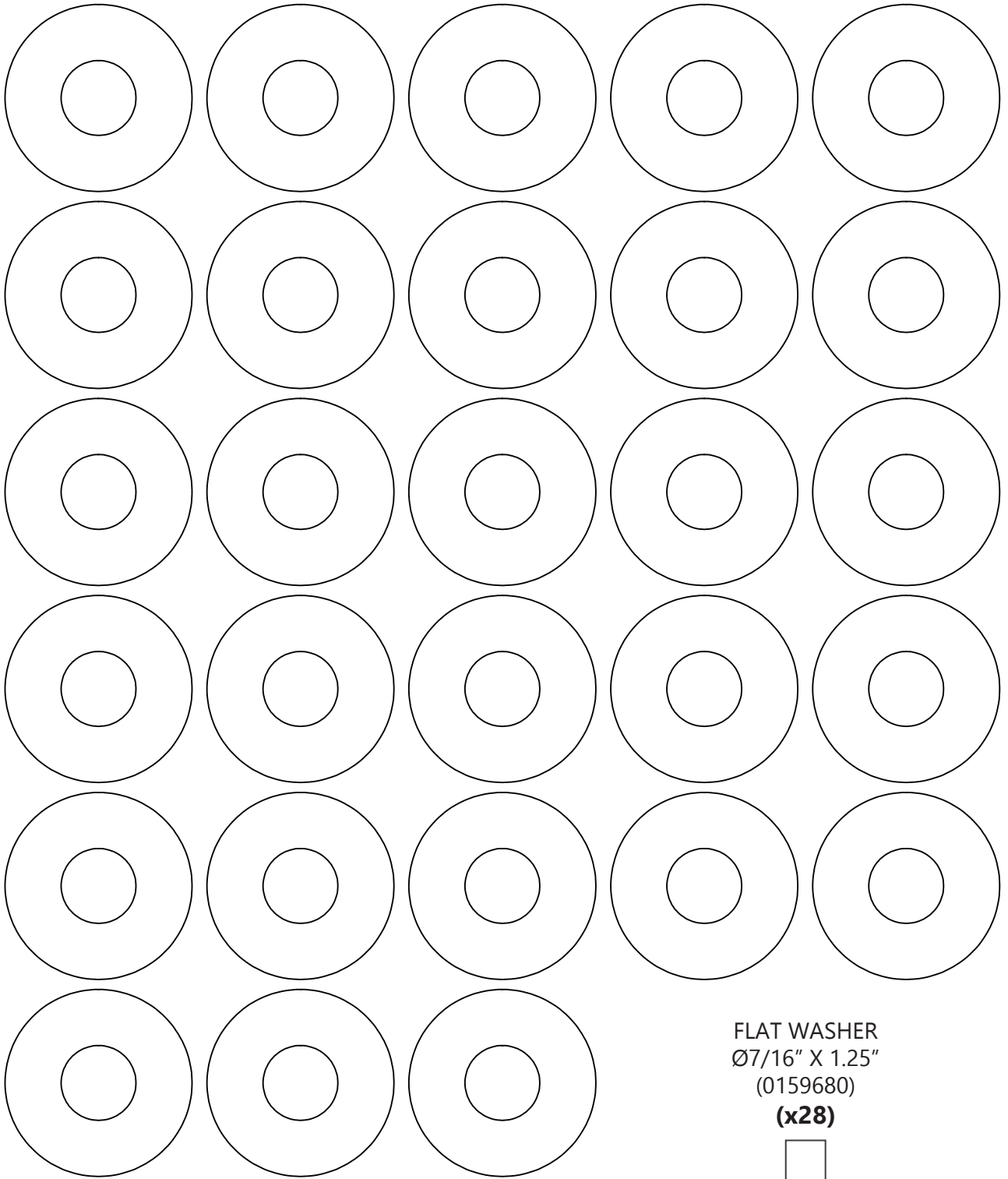

FLAT WASHER  
Ø7/16" X 1.25"  
(0159680)  
**(x28)**





**Jeep JK / JL / JT**  
**BLACK-OPS SERIES**  
**FULL WIDTH WINGS**  
SHIPPING SHEET - BOX 2

Packaged by:

\_\_\_\_\_

On:

\_\_\_\_\_

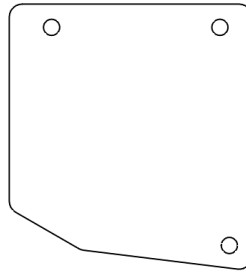

BLANK LIGHT BEZEL  
2AFL2000-01

**(x2)**

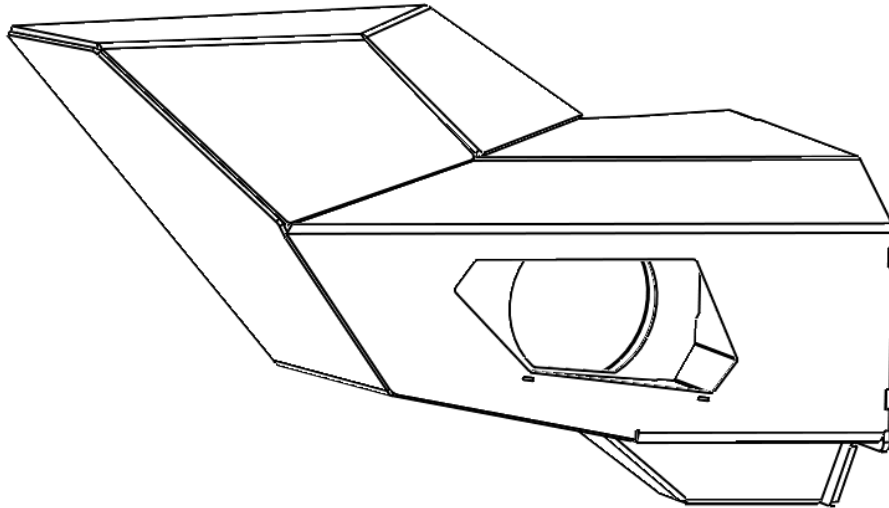
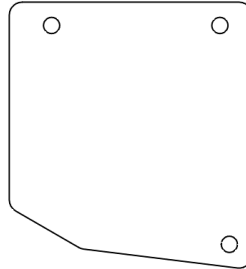

JK/JL/JT FULL WING - PS  
4JFB1880-03

**(x1)**



JK/JL/JT FULL WING - DS  
4JFB1880-06

**(x1)**

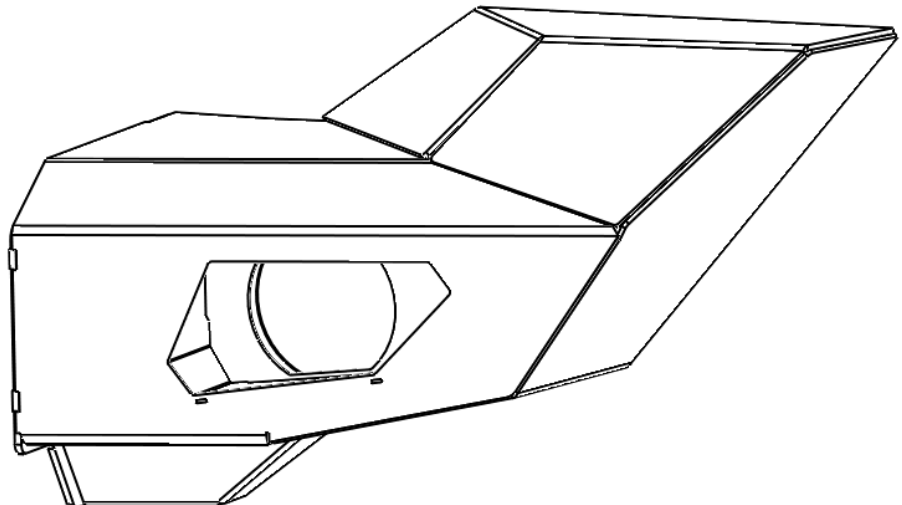



**Jeep JK / JL / JT**  
**BLACK-OPS SERIES**  
**SHORTY WINGS**  
SHIPPING SHEET - BOX 2

Packaged by:

\_\_\_\_\_

On:

\_\_\_\_\_

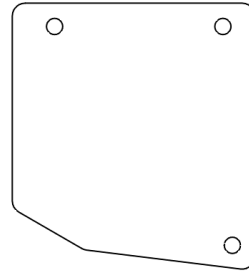

BLANK LIGHT BEZEL  
2AFL2000-01

**(x2)**

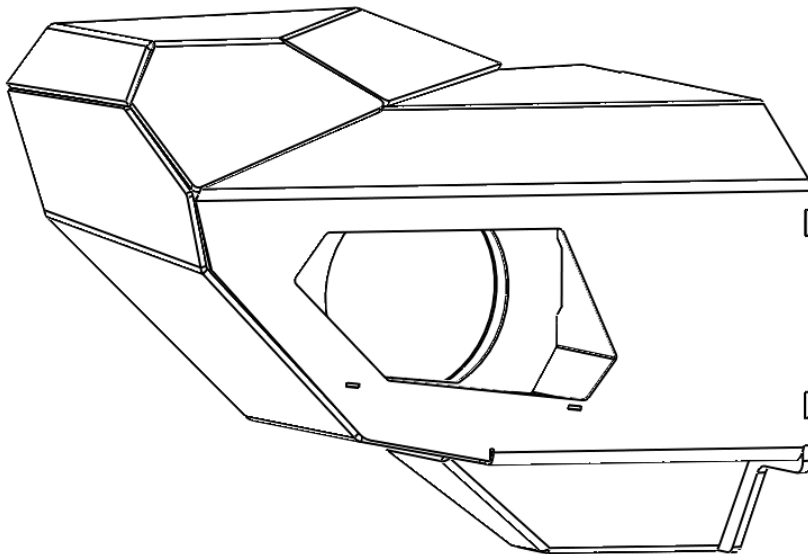
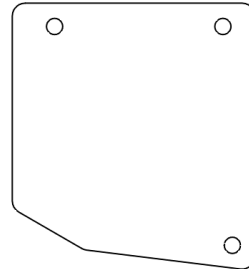

JK/JL/JT SHORTY WING - PS  
4JFB1884-01

**(x1)**



JK/JL/JT SHORTY WING - DS  
4JFB1884-02

**(x1)**

