

## JL Hiline Rear Bumper PART #JK-2966

### PARTS LIST:

1	Hiline Rear Bumper	2	14mm x 40mm Fine Thread Hex Bolts
1	License Plate Bracket	4	14mm x 28mm x 3mm Flat Washers
1	License Plate Light	4	14mm Lock Washers
2	License Plate Plugs	2	14mm Fine Thread Hex Nuts
2	Mesh Panels	6	6mm x 20mm Button Head Combo Bolts
4	Plastic Retaining Caps	2	6mm Nylon Lock Nuts
4	20mm x 10mm Foam Spacers	4	6mm Flange Nuts
4	15.5mm x 25mm OD x 2mm Foam Washers	2	Wire Quick Taps
4	Plastic Sensor Covers	2	Wire Ties
1	Sensor Cover Kit	1	Tire Carrier Hole Plug
1	14-1.50mm Fine Thread Double Nut Plate	1	4mm Wrench

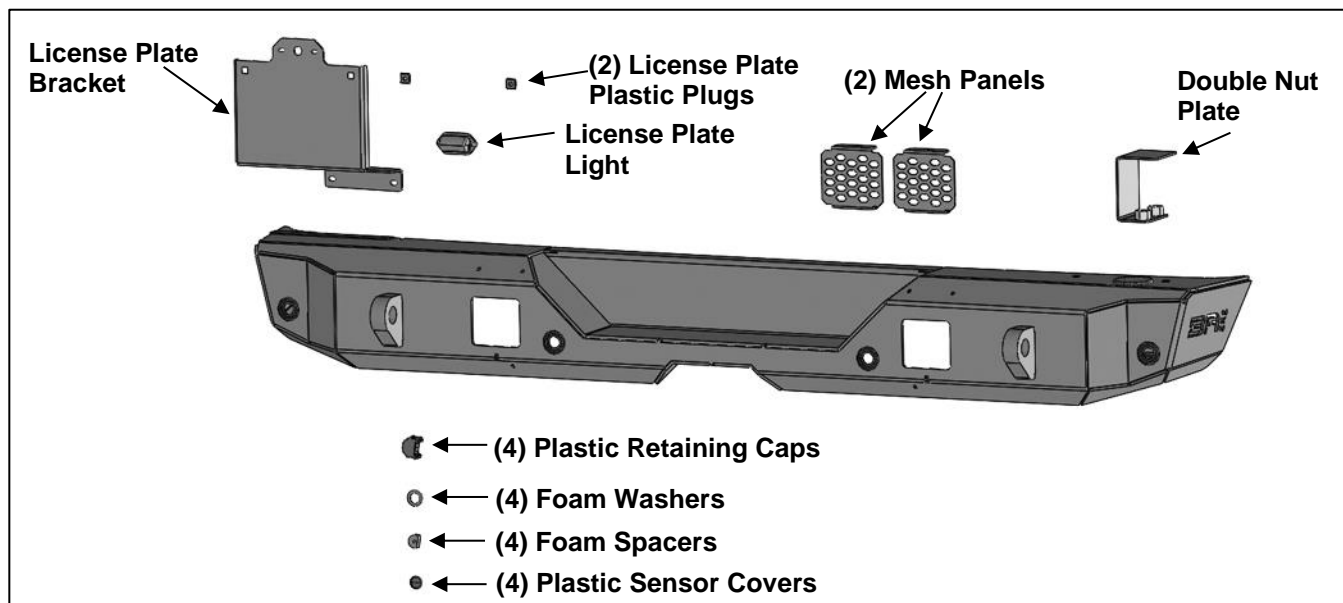

### PROCEDURE:

REMOVE CONTENTS FROM BOX. VERIFY ALL PARTS ARE PRESENT. READ INSTRUCTIONS CAREFULLY BEFORE STARTING INSTALLATION. WARNING: ALLOW TIME FOR THE MUFFLER TO COMPLETELY COOL BEFORE REMOVING REAR BUMPER.

1. Start installation from under the driver/left side of the rear bumper. Remove the plastic cover from the back of the rear wheel opening, **(Figure 1)**. Locate and remove the (2) hex bolts attaching the outer bracket running from the side of the frame to the outer end of the bumper, **(Figure 2)**. Remove the (2) hex bolts attaching the bottom of the bumper to the rear crossbar if equipped, **(Figure 3)**. Repeat this **Step** on the passenger/right side of the vehicle. Unplug the wiring harness leading to the rear bumper.
2. With assistance, remove the (4) hex nuts attaching the bumper to the inner bumper brackets, **(Figure 4)**. Slide bumper off of the inner and outer bumper brackets.
3. Remove the driver/left outer bumper bracket attached to the side of the frame, **(Figure 4)**. Next, remove the (2) hex bolts attaching the tow hook to the side of the frame and remove the inner bumper bracket,

(Figure 5). **NOTE:** It may be necessary to loosen the (2) bolts attaching the tow hook to the bottom of the frame to remove the bumper bracket.

4. Repeat **Step 4** to remove the Passenger/right side bumper brackets.
5. Determine if the model of vehicle has a center support bracket attached to the back of the crossbar. Remove the center support bracket from the crossbar, (**Figure 5**). Reuse the factory bolts, (2) 14mm Flat Washers, (2) 14mm Lock Washers and (2) 14mm Hex Nuts.
6. Insert the Double Nut Plate into the open end of the frame. Line up the Nut Plate with the holes in the bottom of the frame, (**Figure 6**).
7. If lights will not be installed, select (1) Mesh Panel. Attach the Mesh Panel to the back of the bumper with (2) 6mm Combo Button Head Bolts and (2) 6mm Flange Nuts, (**Figure 7**).
8. **Determine if the vehicle is equipped with parking sensors. NOTE:** Depending on tow package, it may be necessary or easier to install sensors, (if equipped), before attaching the Bumper.

**Models without parking sensors:**

- a. Select (1) Plastic Sensor Cover.
- b. Insert the Cover into the front of the sensor mounting sleeve, (**Figure 8**).
- c. Repeat previous **Steps** to insert the remaining (3) Plastic Sensor Covers.

**Models with bumper mounted sensors:**

- a. Disassemble the factory bumper to remove the wiring harness and sensors.
  - b. Select (1) parking sensor. Remove the seal from the end of the sensor. Slide (1) Foam Washer over the front of the sensor.
  - c. Insert the sensor with Foam Washer into sensor sleeve on the back of the Bumper.
  - d. Place (1) Foam Spacer over end of the sensor. Push Sensor Retaining Cap into sensor mount and lock into mounting sleeve, (**Figure 9**).
  - e. Repeat previous **Steps** to attach the (3) remaining sensors.
  - f. Attach the wiring harness to sensors.
  - g. **Optional:** Secure each sensor to the sensor sleeve with (2) 4mm x 10mm Button Head Screws. **IMPORTANT:** Sensors fit snug in sockets. The 4mm Screws are used to apply slight pressure to lock the sensors in place. Tighten both screws evenly until they touch the sensor body only. Do not overtighten screws or damage to sensors will result.
9. With assistance, carefully position the Rear Bumper up to the outside of the frame. Attach the Bumper to the Nut Plate in the passenger/right frame end with (2) 14mm Fine Thread Hex Bolts, (2) 14mm Lock Washers and (2) 14mm Flat Washers, (**Figure 10**). Reuse the (2) factory hex bolts to attach the Bumper to the threaded inserts in the side of the frame. Reuse (4) factory hex bolts to attach the driver/left side of the Bumper to the frame, (**Figure 11**). Do not tighten hardware.
  10. Level and adjust the Rear Bumper and tighten all hardware.
  11. Select the License Plate Bracket. Attach the Bracket to the top of the Bumper with (2) 6mm Combo Button Head Bolts and (2) 6mm Flange Nuts, (**Figure 12**). Select the License Light. Temporarily remove the hardware in the Light and slide the wires through the large round hole in the top of the License Bracket. Reuse the Light hardware to attach the light to the Bracket, (**Figure 13**). Insert (2) License Plate Plugs into the top holes in the Bracket, (**Figure 14**).
  12. Plug-in the bumper wiring harness to the main harness.
  13. Do periodic inspections to the installation to make sure that all hardware is secure and tight.

**To protect your investment,** Do not use any type of polish or wax that may contain abrasives that could damage the finish. Mild soap may be used to clean Bumper.

## Driver/left Side Installation Pictured

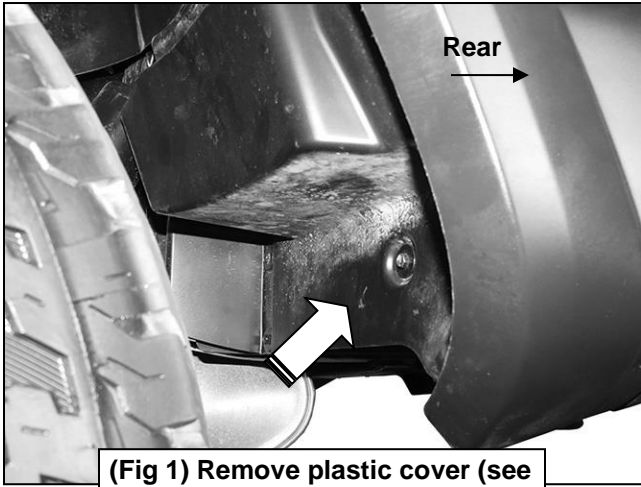

(Fig 1) Remove plastic cover (see arrow-driver/left side pictured)

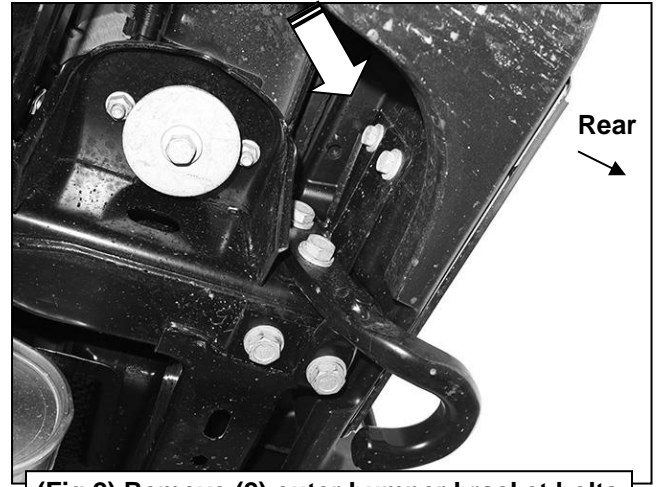

(Fig 2) Remove (2) outer bumper bracket bolts



(Fig 3) Remove (2) hex bolts attaching bottom of bumper to frame cross member

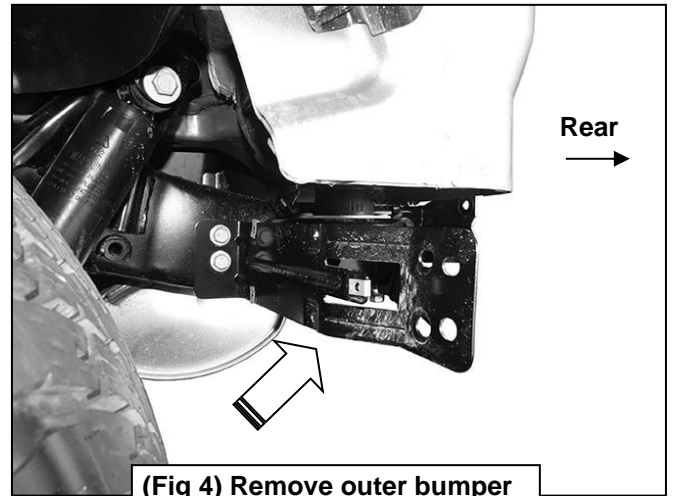

(Fig 4) Remove outer bumper bracket from side of frame

## Driver Side Installation Pictured

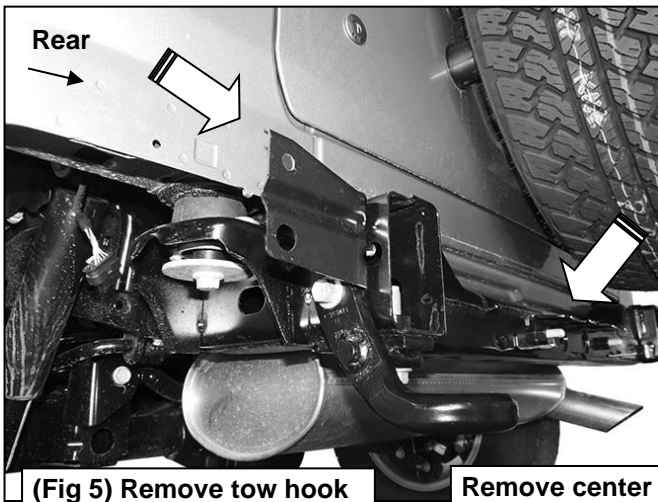

(Fig 5) Remove tow hook and inner bumper bracket from side of frame

Remove center bumper support bracket from the back of the frame

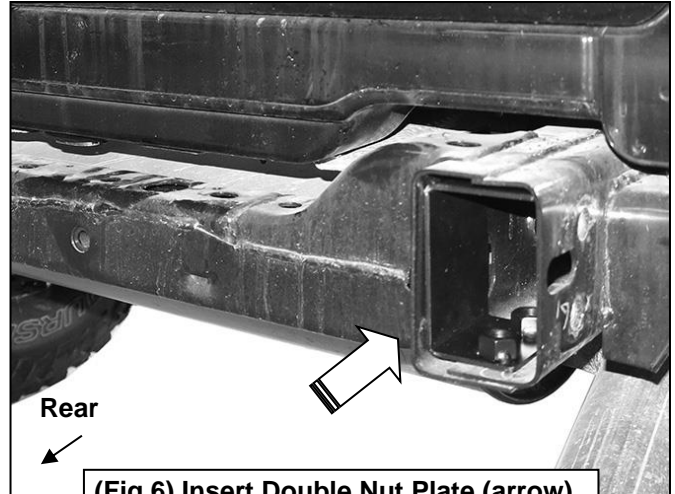

(Fig 6) Insert Double Nut Plate (arrow) into passenger/right end of frame

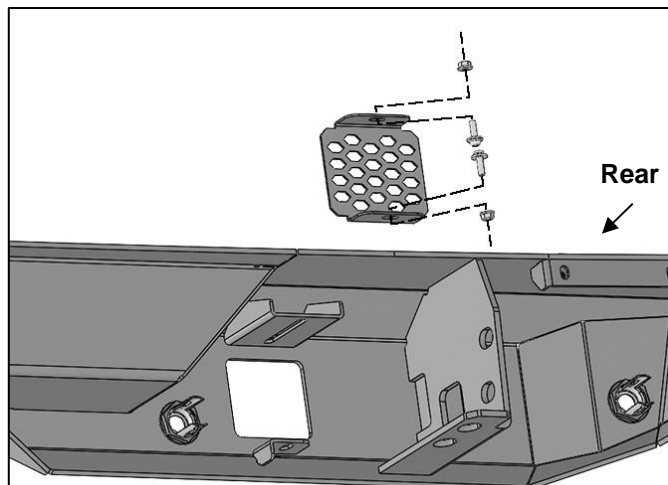

(Fig 7) Before installing Bumper, remove screens as required for clearance around lights (not included)

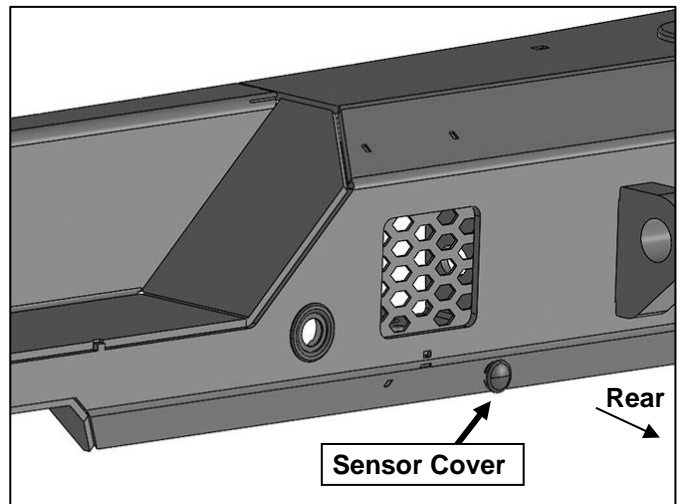

(Fig 8) Insert the Plastic Sensor Cover into the mounting sleeve

**Driver Side Installation Pictured**

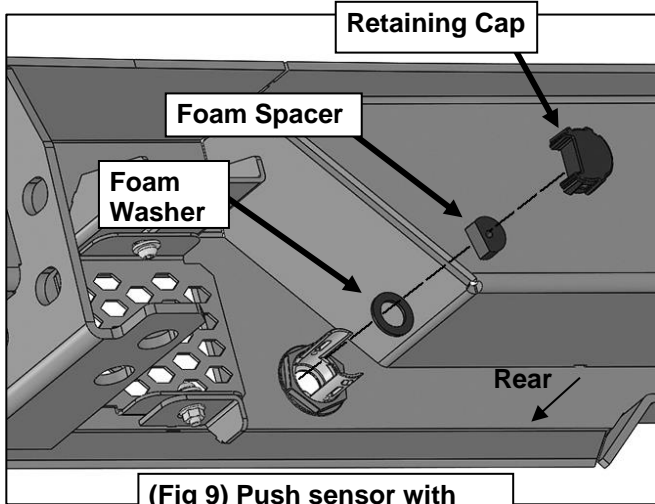

**(Fig 9) Push sensor with Sealing Washer into sleeve**

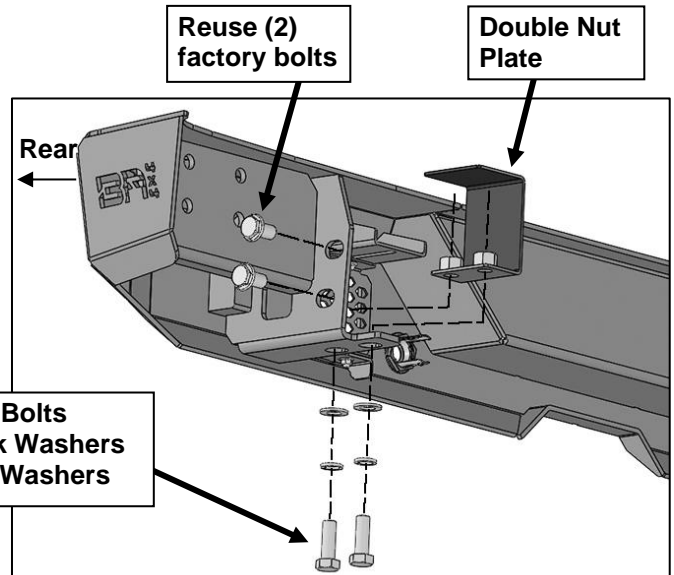

**(Fig 10) Attach passenger/right side of Bumper to Double Nut Plate. Reuse (2) factory hex bolts to attach Bumper to side of frame (see Fig 11)**

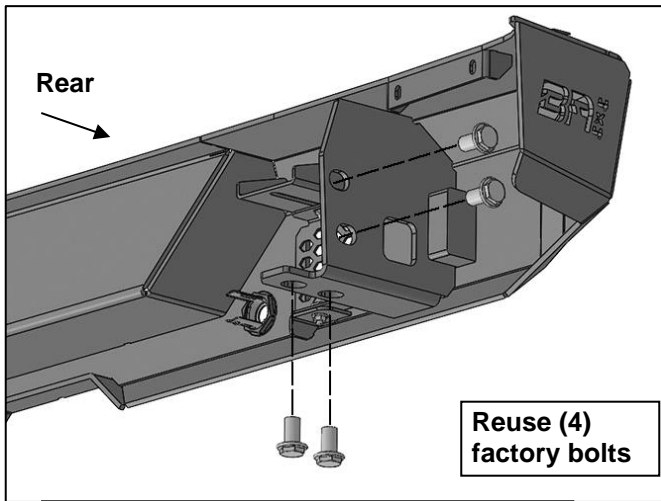

**(Fig 11) Reuse (4) factory bolts to attach the Driver/left side of the Bumper**

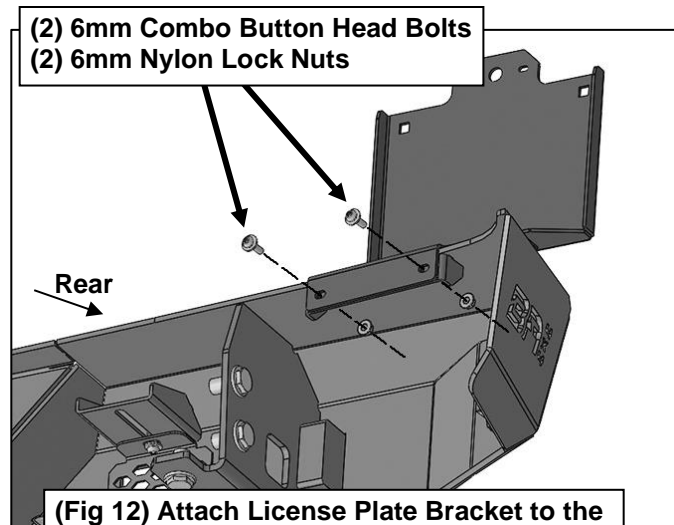

**(Fig 12) Attach License Plate Bracket to the top of the driver/left side of the Bumper**

## Driver Side Installation Pictured

