

Quadratec® Adventure Top S With Flip Back Sunroof

For 2007-2018
4 Door Jeep® Wrangler JKU
Item #11113.1535



WARNING

Loss of vehicle control involves risk of death or serious injury, particularly to parts of your body not restrained within vehicle. This product is intended for weather protection only and should not be relied upon to contain occupants in the event of an accident or to protect from either ground contact or falling objects. To reduce risk of accident or injury:

- ALWAYS WEAR SEATBELTS
- Always keep head, arms & body parts within vehicle.
- Fully secure or stow the soft top before driving according to instructions. Never try to latch or fold soft top while driving. Do not use if damaged or worn.
- Read and follow all instructions & warnings accompanying this product, in your vehicle owner's manual and Off Road Driving Supplement.

CAUTION

RISK OF EYE INJURY. Safety glasses should be worn at all times while installing or maintaining this product.

PART LIST:

TOP DECK/HEADER ASSEMBLY	QTY 1
DRIVER SIDE QUARTER WINDOW	QTY 1
PASSENGER SIDE QUARTER WINDOW	QTY 1
REAR WINDOW	QTY 1
REAR BOW ASSEMBLY	QTY 1
CENTER BOW ASSEMBLY	QTY 1
DRIVER'S SIDE DOOR SURROUND	QTY 1
PASSENGER SIDE DOOR SURROUND	QTY 1
DOOR SURROUND KNOBS	QTY 6
REAR STRAP ASSEMBLIES	QTY 2
OVER DOOR BOW QUICK RELEASE	QTY 2
4MM ALLEN HEAD WRENCH	QTY 1

REQUIRED TOOLS:

SAFETY GLASSES
PHILLIPS SCREW DRIVER
FLAT HEAD SCREW DRIVER
SOCKET WRENCH
13mm SOCKET
PLIERS



The Trusted Source

Important Safety information

Your QuadraTop® soft top is intended to increase the utility and enjoyment of your offroad capable vehicle. Before installation, please take a moment to review the following safety information

and installation instructions. Important safety information is generally preceded by one of three signal words indicating the relative risk of injury.

The signal words mean:

WARNING a hazardous situation which, if not avoided, could result in death or serious injury. You CAN be KILLED or SERIOUSLY HURT if you don't follow instructions.

CAUTION a hazardous situation which, if not avoided, could result in minor or moderate injury. You CAN be moderately HURT and also may suffer property damage if you don't follow instructions.

NOTICE Careful attention is required to this instruction or operation but does generally not relate to personal injury. Damage to your Quadratec® product or other property may result if you don't follow instructions.

Before you begin Installation:

Congratulations on your purchase of the QuadraTop! This high quality soft top is designed to provide years of protection from whatever nature can throw at you! We have used only the finest materials in creating this soft top but like any product that is exposed to the elements, there is some general maintenance that is required to keep your QuadraTop looking like new. Please see page 14 for these important maintenance tips as well as page 13 for available hardware components that may have been lost

or worn over the years.

Thank you again for your purchase and let's start the installation process!

When unpacking, check to make sure all parts are included. If any part is missing or broken, please call Quadratec Customer Service at 800-745-6037 as soon as possible.

Important: Make sure you become familiar with the installation process of this top by reading the following instruction sheet thoroughly.

Pre-installation & Initial Steps:

NOTICE For a smooth fit and ease of installation, this top should be installed at temperatures above 72 degrees. Below this temperature, the fabric may contract an inch or more making it difficult to install. We highly recommend taking the top out of the package and letting it sit inside a warm place or direct sunlight for 1-2 hours before you install the top. When warm, this top will install quickly.

Please also note that it is normal for fabric to contract and wrinkle when stored in the shipping carton. In a few days the fabric will relax and wrinkles will disappear.

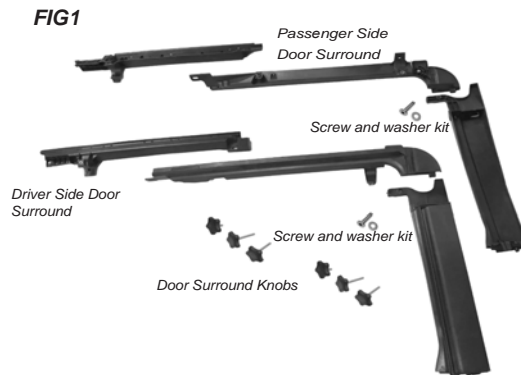

Step 1: Door Surround Assembly:

Put on safety glasses. Carefully remove all the contents of the large shipping box onto a table top or onto the ground on top of a soft towel making sure the driver's and passenger side components are separated.

Once the components are removed from the shipping box, locate the front and rear door surround components and knobs (FIG1).



The Trusted Source

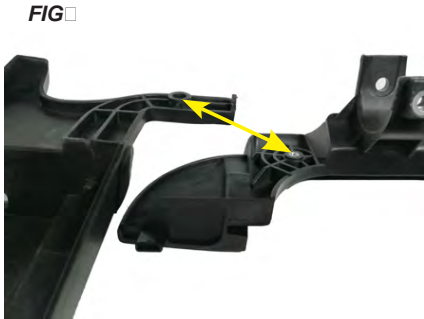

Step 1: Rear Door Surround Assembly
 Locate the driver's side rear over door assembly and the driver's side Pillar assembly shown in FIG 2

In the Driver's side Rear over door assembly, there is a screw and washer installed for shipping (Fig 3). Remove this screw and washer using the included 4mm Allen head tool and set aside (Do not lose this screw/washer).

Line up the Driver's side rear over door assembly and the driver's side Pillar assembly as shown in Fig 4 making sure the holes line up. Place the washer over the top of the hole as shown in Fig 5 and insert the screw (Fig 7). Tighten this screw securing the two pieces (Fig 7a).

Remove the screw and washer from the driver's side rear over door and set aside.



The Trusted Source



Step 1: Install Rear Door Surrounds to Jeep
 Locate the assembled Driver's side rear door surround (Fig 8). On the bottom of the vertical pillar portion of the assembled door surround is a pin that will be inserted into the body tub as shown in FIG9.

On the body tub you may have a rubber seal that is called out in FIG 10. This seal will remain on the body tub. Insert the door surround pin into the

body tub as shown in FIG11. (With the rubber seal still on the vehicle). After inserting the pin, locate the upper portion the door surround "C" attachment and push onto roll bar (Figs 12 & 13).

The "C" should fit in the cutout of the roll bar pad. Line up the threads in the "C" with the top hole in the roll bar.

Repeat this procedure on the passenger side.



The Trusted Source



Step 1: Secure Front & Rear Door Surrounds to Roll Bar

Locate the two sets of screw knobs in each Door surround box. There should be (2) sets of three knobs with two the same length and one shorter length. The shorter knob attaches to the center hole on the door surrounds and the (2) longer knobs go on the front and rear holes.

Line up the door surround "C" attachment holes with the vertical holes in the roll bar. Slip the front knob through

the hole in the front door surround (FIG 4). Tighten the knob securing the front door surround. Repeat this procedure on the back of the rear door surround. Finally, with the short knob secure the "sandwiched" front & rear door surrounds with the short knob and tighten all three knobs (FIGs 5 & 6). All knobs on both sides of the vehicle should be secured to the roll bar.

This completes the installation of the door surrounds to your vehicle.



Step 2: Attach Quick Release Knobs to Over Door Bows

Locate the two Quick release knobs and the header/Deck Assembly shown in FIG 8. You will be installing one Quick release knob into each of the over door bow ends. Line up the quick release knob in the bow end making sure the knob portion is facing inward and the slot on the Quick Release knob is vertical, up and down (FIG 9).

Using a Phillips head screw driver and the enclosed set screws, secure the Quick Release knob to the bow end through the pre-drilled hole in the bow (FIG 20).

NOTE: If you cannot get the hole started in the Quick release knob, you may have to drill a small pilot hole.

Tighten the screw securing the Quick Release knob to the bow. Repeat on the other side.



The Trusted Source

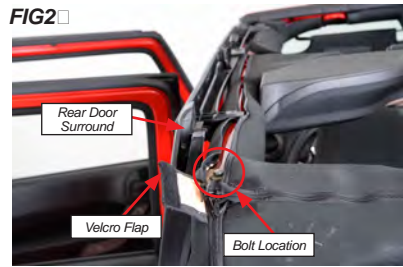

Step 2: Installing the Rear Bow
 Locate the rear bow as circled in FIG22. This bow is curved at the end and has a flat bracket welded onto each end as shown in FIG23. This bow mounts to the factory mounting point on the rear of the roll bar under the Roll Bar padding and just behind the rear door surround (FIG 24).

Un-zip the roll bar padding towards the rear of the vehicle just past the rear door surround and right after the small Velcro flap as shown

in FIG24. There will be a factory mounted bolt just under this flap. Using a 13mm socket and driver, remove this bolt from the roll bar (FIG25). Once removed, slip the rear bow bracket over the hole and replace the bolt (FIG 26)

Note: the rear bow mount has a slotted hole. This is due to the rear roll bar being slightly different on different Jeeps. Make sure the bow is centered (FIG 27a) and not off to one side as shown in FIG 27 when installed.

Repeat this install on the other side of the vehicle and then re-install the roll bar padding. The rear bow bracket should come right out under the Velcro flap (FIGS 28, 29 & 30).





Step 3: Installing the Two Center Bows

Locate the second center bow as circled in FIG3. This bow has a flat bracket welded onto each end as shown in FIG32.

This bow mounts to the rear Door Surround knob location. Remove the rear door surround Knobs from each side of the vehicle and place the second center bow bracket

hole over the door surround hole (FIG33). Make sure the bow is rear of the Door Surround Knob. Line up one side and place the long door surround knob into the hole securing the center bow (Do not tighten yet) (FIG34). Go to the opposite side of the vehicle and line up the holes and place the knob in the hole. Now tighten each knob securing the bow to the door surround.

NOTICE

This next step is easier and safer if you have a friend helping you. Having a person on the other side of the vehicle to help lift and locate the front header assembly will be very helpful.

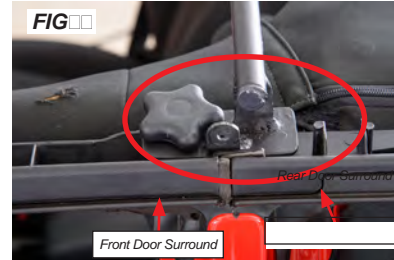

The Trusted Source

Step 1: Installing the Two Center Bows The first center bow as circled in FIG35 has been permanently installed to the deck assembly. To install this bow, you will need to place the soft top on top of the vehicle (Have a friend help!) with the front header resting on the windshield and the rest of the soft top towards the rear of the vehicle (FIG36). Now fold back the Windshield header as shown in FIG37 which will

the door surround hole. The center bow should be towards the rear of the vehicle. Line up one side and place the short door surround knob into the hole securing the center bow (Do not tighten yet) (FIG38).

Go to the opposite side of the vehicle and line up the holes and place the knob in the hole.

FIG 35



Step 2: Installing the Top Deck and Front Windshield Header Assembly

With the first bow installed to the vehicle and the front windshield header folded back (FIG42). Locate the Quick Release knobs on the ends of

FIG 37



expose the bow mount brackets installed on the first bow. The bow ends on the first bow have a multi piece bracket welded to the end of the bow (FIG39). This center bow attaches to the vehicle using the door surround knob installed in step 7 above, located in between the front and rear door surround (FIG40). Remove these door surround Knobs from each side of the vehicle and place the center bow bracket hole over

Now tighten each knob securing the bow to the door surround (FIG41).

NOTE: The oval cutout on the bow bracket must fit into the oval on the door surround. It should be flush when installed and there should be very little if any movement of this bracket once secured with the door surround knobs.



the over door bows and slip the knob into the hole in the first bow mount (FIG43) by pulling the knob out and then releasing. Repeat on the other side. This will secure the back of the header assembly to the vehicle (FIG44).

FIG 42



The Trusted Source

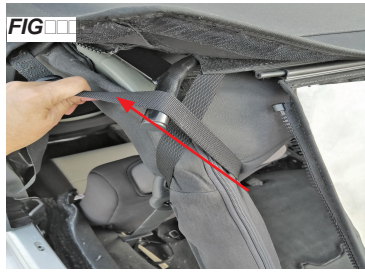

FIG5

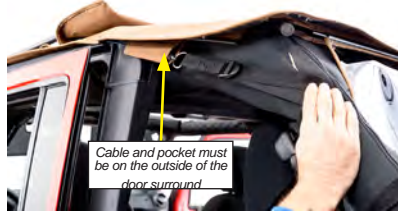

FIG5



Step 1: Installing the Top Deck
 With the rear of the header secured and the front header resting back towards the rear of the vehicle and on top of the rear bow (FIG45) go to the rear of the vehicle and locate the rear hook and loop flaps on the rear of the top deck. Attach the rear bow flap (Hook and loop fastener) to the rear bow as shown in FIG4. Locate the rear spring straps that are sewn on the rear end of the deck (FIG 47). This strap will wrap under the rear seat belt post (FIG's 47 & 48) and then from the inside and around the roll bar back up towards the rear bow leg (FIG 49a). As shown in FIG 49b, make sure the strap comes from the inside of the vehicle out and up towards the front of the vehicle and over the Rear bow leg. Attach the strap end to the buckle/D-Ring assembly.

Thread the end of the D-Ring through the flap/ tube sewn into the top deck (FIG50) and attach the D-Ring to the spring assembly that is hanging out of the top deck (FIG5). Using a pair of pliers, crimp the spring end slightly to keep the D-ring from sliding off the spring. Repeat this procedure on the other side of the vehicle and loosely tighten these straps, starting on one side and alternating to the other so the top deck is centered. When Tightening, the cable that is attached to the spring will fit under the pre-installed screw on the door surround (FIG's52 & 53). You will fully tighten these straps later.

NOTE: Do not fully tighten these straps until advised to do so in step 13 when the front header is closed on the windshield. If these straps are fully tightened before you fold down the front header you will damage the Top!



The Trusted Source



Step 1: Installing the Side and Rear Windows
 To ensure the top is centered on the vehicle you will be installing the two quarter windows and the rear window to the top deck and to each other before securing it to the vehicle body. **Pro-Install TIP:** To make this as easy as possible, you may have to release the front windshield header (release but not un-hook) and keep the rear corner straps installed in step 10 loosened. This will allow you to line up all window zippers and attachments. The rear corner straps and header will need to be retightened/clamped before using the top. Locate the drivers rear quarter window. Line up the driver's side quarter window to the zipper on the deck and zip it as shown in FIG's 54 & 55 Repeat this on the passenger side of the vehicle. Locate the rear window and line up and slide the rear window into the "C" Channel located at the top of the rear portion of the top deck and slide it across (FIGs 57 & 58). Once both quarter windows and the upper portion of the rear

window are secured to the top deck, line up the driver's side rear zipper on the Quarter window to the zipper on the rear window and zip it down a few inches (FIG59). Repeat this on the passenger side of the rear window. You may have to lift the quarter window up to secure this second zipper a few inches. Once both side zippers are attached, zip the rear window zippers down about a quarter of the way (FIG60). You will close these zippers completely at the end of the install. With the header resting on the windshield and the over door bows installed, close the front header latches to secure the front of the top to the windshield. See FIG's 62 & 63 above. With the front header latched, tighten the rear corner straps making sure that the top is centered on the vehicle and the cable/pocket is on the outside of the door surround (FIG4) and that the cable is secured under the screw on the door surround (FIG5).



The Trusted Source

NOTICE

When removing the quarter and rear windows from the Top deck be sure to completely remove the zipper pin from the Zipper box. Disengage the side hook and loop before un-zipping the windows. DO NOT "Peel" the windows out!



Step 1: Securing the Side and Rear Windows to the Vehicle

As shown in FIG's 6, 7, & 8, roll the vertical plastic strip into the door surround slot securing it to the door surround. Starting at the driver's side front, attach the side belt rail into the vehicle body by "rolling" the plastic into the slot (FIG 9 & 70). Once secure move to the rear

driver's side corner and "roll" the plastic into the Jeep body corner belt rail while pulling back towards the rear of the vehicle as shown in FIG7. Repeat the quarter window install on the passenger side of the vehicle. You may have to pull the corners around towards the front or back of the vehicle to center the top on the vehicle and to pull the zippers closer.



The Trusted Source

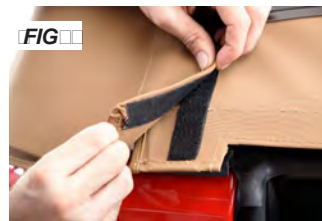
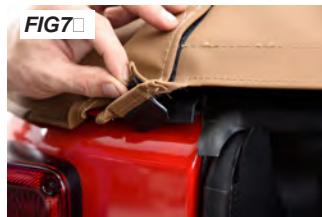

Step 1: Securing the tailgate bar & top to the vehicle

Open the tailgate. Take the factory bar and orient the "C"-Channel with the round seal facing down and slide the "C" Channel onto the rear window retainer as shown in FIGs 72 & 73. Clip the rear Tail gate retaining brackets to the body tub just outside the tailgate opening. Roll the tailgate bar

into the mounts with the outside of the fabric facing towards the rear rear of the Vehicle (FIGS74 & 75). Once the Tailgate bar is secure, lower zippers on both sides of the rear curtain and then secure the rear zipper cover flaps as shown in FIG7. Work your way around the outside of the vehicle and secure all Hook and loop sealing up the zippers and holes (Figs77, 78, 79 & 80).

Step 16: Securing the bow flaps to the bows
With the top installed, go inside the vehicle and

secure the hook and loop flap to the second bow making sure it is secure. See Warning below:

WARNING

Make sure the hook and loop fastener are tightly secured to the second and rear bow before the front sun roof is folded back. Both rear corner straps must also be secure when the top is folded back. Make sure these flaps are secure before driving. These safety measures are designed to secure the top deck to the vehicle (along with the permanently installed first bow) and if not adhered to can cause injury, death and a serious accident. Always wear your seat belts when using this product!



The Trusted Source

Flip-Back Front Open:



QuadraTop



Replacement Hardware & Soft Top Accessories available at Quadrattec.com

Please review this set of instructions, and examine your original equipment hardware. Is any hardware missing or damaged? Quadrattec offers a full assortment of original equipment hardware and accessories to keep your top looking new and performing at its peak. The following parts and current pricing are available at Quadrattec.com

- > Complete Bow Assemblies: #11132.95XX
- > Soft Top Emergency Repair Kit: #91083.4201
- > Zipper Slick Zipper Lubricant: #91083.4200
- > Soft Top Cleaner & Protectant: #91083.110X
- > Soft Glass Window Polishes: #91083.11XX

*Don't see what you need on the list? Call for Expert Advice at **800-745-5337***



The Trusted Source

Care and Maintenance:

Your QuadraTop is made of the finest materials available but to keep it looking new and for the maximum possible wear, it will need periodic cleaning and basic maintenance. The main threats to your soft top are pollutants, dirt and grime. By keeping your soft top clean you will prolong the life of your top. We recommend the following to keep your top like new:

Washing: The soft top fabric should be washed often using a mild soap, warm water and a soft bristle brush (do not use the brush on the window glass!). You can also use special soft top cleaners available on our website and shown on page 15. Make sure that after cleaning you rinse with clear water to remove all traces of soap.

Zippers: Keeping the zipper cleaned and lubricated with a silicone lubricant (see Page 15) will help prevent damage and keep the zippers in a smooth working condition. If zipper opens behind the slider, the slider may have been spread apart. This problem can usually be fixed

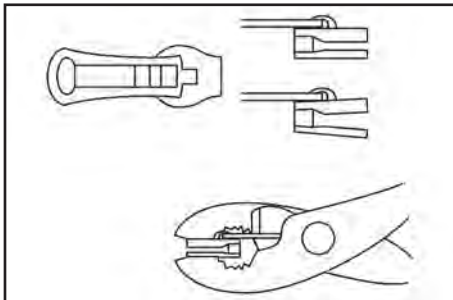

by using an ordinary pair of pliers to bring the sides back into parallel. Return slider to the end of the zipper in the normal Open position. Squeeze lightly at

First and test zipper. If the zipper continues to remain open squeeze more firmly with pliers and try the zipper again. Repeat procedure until your zipper operates correctly.

Windows: It is very important that you keep your QuadraTop windows clean! Use a mild soap and water solution to gently clean your windows. NEVER wipe your windows clean with a dry cloth! Dust and dirt on a dry cloth can scratch your windows causing "fogging" and permanent damage. When removing your windows, store them with a towel between the panels/rear windows to protect them from damage. If frost or ice forms on the outside of your windows during the winter, DO NOT use an ice scraper to remove this frost. Over time you will see small micro scratches in your windows which are natural wear and tear. These Micro scratches can be "polished" out using the window polish listed on page 15 (Available at Quadrattec.com).

Water/Fabric: In the event of seeping through the seams, 3M Scotchgard® may be applied on the inside of the seams to stop the see. Rips in the fabric may be repaired with Bondex® iron on patches. Iron the patches to the Inside of the top, carefully following the Bondex® instructions.

Snaps: Keep snaps cleaned and lubricated with silicone to help prevent snaps from sticking to the studs. If a snap does become stuck to a stud, use a screwdriver and GENTLY pry apart to prevent permanent damage to the snap or the top fabric.



The Trusted Source

Quadratec Limited Warranty

for QuadraTop® Replacement Soft Tops

Your QuadraTop® replacement soft top is covered by the following Limited Warranty provided exclusively by Quadratec, Inc. 1028 Saunders Lane, West Chester, PA 19380.

This **Limited Warranty** is the only warranty made in connection with purchase. Quadratec neither assumes nor authorizes any vendor, retailer or other person or entity to assume for it any other obligation or liability in connection with this product or **Limited Warranty**.

What is Covered:

Subject to the terms, exclusions and limitations herein and with respect only to soft tops first sold in the United States, Quadratec warrants to the initial retail purchaser only that your QuadraTop soft top shall be free of defects in material and workmanship **for a period of 3 years from date of initial retail sale**.

All other warranties are hereby disclaimed, except to the extent prohibited by applicable law in which case any implied warranty of merchantability or fitness for a particular purpose on this product is limited to 3 years from date of initial retail sale. Quadratec reserves the rights to: (a.) require invoice or other proof your soft top is within the terms of this **Limited Warranty** as a condition of warranty service and, (b.) make future revisions to this product and **Limited Warranty** without prior notice or obligation to upgrade your soft top.

What is Not Covered:

Your Quadratec **Limited Warranty** does not cover products or parts Quadratec determines to have been damaged by or subjected to: (a.) installation damage, alteration, modification, failure to maintain or attempted repair or service by anyone not authorized by Quadratec, (b.) normal wear and tear, cosmetic damage or damage from water immersion, (c.) Acts of God, accidents, misuse, negligence, inadequate mounting or impact with vehicle(s), obstacles or other aspects of the environment, (d.) theft, vandalism or other intentional damage.

Remedy Limited to Repair/Replacement: **The exclusive remedy provided hereunder shall, upon Quadratec inspection and at Quadratec's option, be either repair or replacement of product or parts (new or refurbished) covered under this Limited Warranty.** Customers requesting warranty consideration on QuadraTop soft top should first contact Quadratec to obtain a RGA number (610-701-3336). All labor, removal, shipping and installation costs are customer's responsibility.

Other Limitations - Exclusion of Damages - Your Rights Under State Law:

In consideration of the purchase price paid, neither Quadratec nor any independent Quadratec distributor/licensee are responsible for any time loss, rental costs, or for any incidental, consequential, punitive or other damages you may have or incur in connection with any part or product purchased. Your exclusive remedy hereunder for covered parts is repair/replacement as described above.

This **Limited Warranty** gives you specific rights. You may also have other rights that vary from state to state. For example, some states do not allow limitations of how long an implied warranty lasts and/or do not allow the exclusion or limitation of incidental or consequential damages, so the limitations and exclusions herein may not apply to you.

The terms Quadratec®, QuadraTop®, Essentials® and Essential® are Registered Trademarks of Quadratec Inc. Registered in U.S. Patent and Trademark Office.

©Quadratec, Inc. 2023. All Rights Reserved.
Version 02.03.23

Part #12999.0212



The Trusted Source