

# QuadraTop® Fabric Replacement Soft Top

Adventure Top Fabric Only  
Replacement Soft Top for 2007-2018  
2 Door Jeep® Wrangler JK Item #11113.0435



## NOTICE

This Replacement Fabric kit is designed to fit on your Factory soft top installed 2 Dr Jeep® Wrangler when portions of your original soft top rear bow assembly has been completely removed. Before beginning your installation of this product, you will need to remove your existing soft top fabric and factory rear bow.

## WARNING

Loss of vehicle control involves risk of death or serious injury, particularly to parts of your body not restrained within vehicle. This product is intended for weather protection only and should not be relied upon to contain occupants in the event of an accident or to protect from either ground contact or falling objects. To reduce risk of accident or injury:

- ALWAYS WEAR SEATBELTS
- Always keep head, arms & body parts within vehicle.
- Fully secure or stow the soft top before driving according to instructions. Never try to latch or fold soft top while driving. Do not use if damaged or worn.
- Read and follow all instructions & warnings accompanying this product, in your vehicle owner's manual and Off Road Driving Supplement.

## CAUTION

RISK OF EYE INJURY. Safety glasses should be worn at all times while installing or maintaining this product.

### PART LIST:

FABRIC TOP - QTY 1  
QUARTER WINDOW, RIGHT - QTY 1  
QUARTER WINDOW, LEFT - QTY 1  
REAR WINDOW - QTY 1  
Driver Side Over Door Bow - Qty 1  
Passenger Side Over Door Bow - Qty 1  
Center Bow Assembly - Qty 1

### REQUIRED TOOLS:

SAFETY GLASSES  
MASKING TAPE  
PHILLIPS SCREW DRIVER  
PLIERS  
LARGE TOWEL



The Trusted Source

### Important Safety information

Your QuadraTop® Fabric Replacement Top is intended to be used with other QuadraTop Products to increase the fair weather enjoyment of your off-road capable vehicle. Before installation, please take a moment to review the following safety information

and installation instructions. Important safety information is generally preceded by one of three signal words indicating the relative risk of injury.

The signal words mean.

**WARNING** a hazardous situation which, if not avoided, could result in death or serious injury. You CAN be KILLED or SERIOUSLY HURT if you don't follow instructions.

**CAUTION** a hazardous situation which, if not avoided, could result in minor or moderate injury. You CAN be moderately HURT and also may suffer property damage if you don't follow instructions.

**NOTICE** Careful attention is required to this instruction or operation but does generally not relate to personal injury. Damage to your Quadratec® product or other property may result if you don't follow instructions.

### Before you begin Installation:

We are excited that you have chosen the Adventure Top Fabric Replacement Top Kit. This high-quality soft top is designed to provide protection from the elements and a stylish look on your Jeep®. Please note that it is important that you become familiar with the installation process of this top by reading the following instruction sheet and warnings thoroughly.

When unpacking, carefully check to make sure all parts are included. If any part is missing or broken, please call Quadratec customer service at 800-745-6037. When unpacking, check to make sure all parts are included.

**NOTICE** For a smooth fit and ease of installation, this top should be installed at temperatures above 72 degrees. Below this temperature, the fabric may contract an inch or more making it difficult to install. We highly recommend taking the top out of the package and letting it sit inside a warm place or direct sunlight for 1-2 hours before you install the top. When warm, this top will install quickly.

### Preparation for Installation of the Adventure Top Fabric Only Replacement Top:



The roll bar mounted Bow bracket stays on the vehicle.

The Factory Door Surrounds also stay on the vehicle.



### Factory Hardware Requirement:

This product is designed to fit over your original factory soft top hardware with the rear bow assembly removed. Please see HARDWARE A to make sure you have the correct hardware for this top and identify which components will be removed.

Please note that the bow mount brackets installed on the roll bar and factory door surrounds will REMAIN on the vehicle and will be used to install the Adventure Top hardware. You will also be re-using your Factory Windshield Header for this install.



The Trusted Source



**Step 1: Remove Existing Soft Top Fabric**

Put on safety glasses. After verifying that you have the correct factory original bow system and hardware, remove the existing soft top from the vehicle.

This process will entail removing all Quarter windows, unscrewing the top from the rear bows and removing the fabric from the windshield header by unscrewing or loosening 19 or 27 header

screws (Depending on model year). See below for Header fabric removal options (Step 1B).

Make sure you keep all screws and fasteners in a safe place after removal. You will be using them again later in the installation. See FIGs 1, 2, 3 & 4. Once the soft top is removed, inspect all of your hardware to make sure no parts are bent or missing.



**Step 1A: Detach Old Top Fabric from Header**

**For Model Years 2010-2018 Only:**

You will need to peel back the corner foam and un-screw the cable attachment on both ends of the header using a Phillips Head Screw driver.

**For Model Years 2007-2009 Only:**

You will need to peel back the foam and remove the two corner screws that hold a plastic mounting flange located in the same vicinity.

See FIGs 5, 6, 7 & 8.

**NOTICE**

The following header installation will be easier to accomplish with the help of another person. This step will most likely be the most difficult step in the install and you should take your time. The easiest way to install this header is standing on the front seats facing forward.

We suggest placing a towel or cover on the seats to protect them from dirt & debris from your shoes. Once the soft top header fabric is installed in the factory header, the remaining installation is very straight forward.



The Trusted Source

**Preparation for Installation of Fabric Only Replacement Top:**



**Step 1B: Remove Fabric From The Header**

After you have removed the corner screws called out in step 1A, there are two ways to remove and replace the fabric on your vehicle's soft top header. Both ways will work but we have found that the quickest way is to just loosen (not remove) the 19 or 27 screws on the header and simply "peel" the old fabric from the header (Fig 9). Then when you install the new fabric to the header, you push the round front attachment on the

fabric back into the header and tighten the screws (see installing the front header later, in step 3).

The second method takes more time as it entails removing all 19 or 27 screws from the header and removing the fabric after the top plate is removed (Fig 10).

Then to install the fabric to the header you place the front round attachment into the header and replace the top plate with the screws (see installing the front header later, in step 3).



**Step 2: Remove the side Over Door Bows from the Front Header Assembly**

After removing the soft top fabric from your existing hardware, locate the front over door bows and remove the rear portion of the bows from the front header portion using a flat head screw driver (Fig 11 & 12).

Un-latch the over door bow from the roll bar mount bracket and the rear bow from the Bow mount bracket (Figs 13 & 14).

Repeat on the other side of the vehicle. With the help of a friend, completely remove this bow assembly from the vehicle (Fig 15).

**Installation of Fabric Only Replacement Top:**

**Step 3: Installation of the Fabric to the Front Header Assembly**

With the original bow assembly removed from the vehicle you now have the front header sitting on top of the wind- shield. Take the front header off the windshield and place on a table or soft towel.

As mentioned in Step 1B, you have two ways to install the front fabric onto the front header. If you just loosened the header top plate screws and "peeled" the soft top fabric from the header channel, proceed to step 3A.

If you removed the 19-27 screws from the top plate, proceed to step 3B.



The Trusted Source

**Installation of Fabric Only Replacement Top:**



**Step 3A: "Quick" Attach the Deck Fabric to the Windshield Header**

With the soft top underside (substrate) facing up and top of the Windshield header also facing up, center the front tube sewn onto the deck onto the header and push the front tube into the space created when you loosened the top plate screws. Working from the center out to each side, push the tube into the slot securing it into the header. Note: if necessary, to help you insert this tube you may want to use an ice scraper or plastic putty knife to push the tube into the slot (Figs 16, 17 & 18).

When the fabric is in the header and you know it is centered (Fig 19), tighten the screws on the

header securing the fabric to the header (Fig 20) including the four corner screws (Fig 21).

Flip the Header over so the underside is facing up (Fig 22). Slip the corner pocket sewn into the top between the header and position the cable anchors over the two holes with the cable facing the outside of the header (FIG 22). Wrap the plastic tab over the cable anchors and reinstall the screws securing the fabric/cable anchors to the header (Fig 23)

Note: On 07-09 models the screw holes may not line up exactly and some hole relocation may be required using a drill.



**Step 3B: Standard Attachment of Deck Fabric to the Windshield Header**

With the metal header top plate removed, slide the sewn in extrusion along the front edge of the top into

the channel of the lower header that is secured to the windshield in step one. See FIG 24.

Locate and line up the center notch in the middle of the fabric to the center of the channel centering the fabric on the lower header. Secure the fabric around the center notch with masking tape. See FIG 25.

**Step 4: Securing the Top in Lower Header**

Working from the center out, secure the top in the lower header channel with masking tape holding it in place for installing the top plate to the lower header.

Use 5-6 pieces of tape to hold the top in place. Note: The tape pieces will be completely covered when the top plate is put back on the lower header.

See FIGs 26, 27 & 28.

Once centered, use a heavy masking tape on each side of the notch in place.



The Trusted Source



**Step 5: Complete Header Re-Assembly**

Close the upper header over the taped down fabric sandwiching the fabric but leaving the underside faced up on the hood (See FIG 29).

Using the screws you removed in step one, reinstall the four corner screws and then the 19 or 27 (depending on model year) screws along the top of the header. See FIG 30 & 31.



Un-latch the bow assembly from the windshield (inside vehicle) and lower the bow assembly to the rear of the vehicle folding the top back over with the underside of the fabric facing down (see FIG 32).



**Step 6:**

**Install Over Door Bows to Front Header**

Take the Fabric/Header assembly from step five and place the assembly on a table top or on a soft towel with the underside facing up and the two "header legs" facing away from the header (Fig 33).

Locate the over door bow assembly (Fig 34) and round header sleeve (round tube). Slip the round door "sleeve" over the header leg and insert the "knuckle" installed on the over door bow into the Header leg (Fig 35).



Making sure the quick release knuckle is facing outward (Fig 36). Note that the over door bow assembly are sided-left and right.

Secure the over door bow to the Header leg with the attached set screw (Fig 37). Slide the bow sleeve over the knuckles as shown in Fig 38. Repeat this procedure on the opposite side.



The Trusted Source



**Step 7: Install Center Bow to the Vehicle**  
 Locate the center bow assembly. With a friend, place the bow assembly over the roll bar and line up the assembly to the original upper bow mount bracket (Fig 40) that were left on the vehicle. The center bow should be towards the rear of the vehicle as shown in Fig 39.



Line up the Quick release knuckle with the upper bow mount bracket attachment and attach each side of the center bow assembly to the bracket (Figs 41, 42, 43 & 44).



Repeat on other side of vehicle.

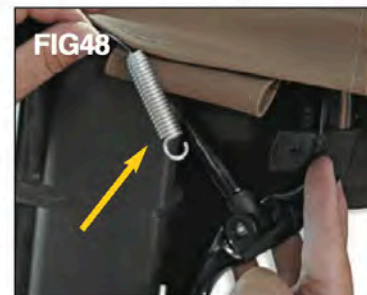

**Step 8: Installing the Header/Deck Fabric Fabric to the Center Bow**  
 With the help of a friend, locate the completed header assembly created in Step 4 and place this assembly over the windshield with the two "header legs" towards the rear of the vehicle. Line the

quick release knuckles to the center bow (Fig 46). Repeat on other side of vehicle. With the over door bows mounted to the center bow, drape the fabric attached to the front header back towards the rear of the vehicle as shown in Fig 47.



The Trusted Source



Locate the center bow webbing and the spring assembly that is attached to the top deck. Figs 48 & 49. Attach the spring end to the webbing as shown in figs 50 and 51.

**NOTE:** Fig 51 shows the spring end coming all the way through the web strap. This is Extremely important! Using pliers, crimp the spring end so it does not come loose.



**Step 9: Installing the Top Deck to the Jeep®**  
With the header resting on the windshield, close the front header latches to secure the front of the top to the windshield. See FIGs 52, 53 & 54.

With the fabric installed on the header and draped over the back of the vehicle, go to the rear corner of the Top deck and locate the rear corner straps.



Thread the straps down and under the seat belt mount as shown in FIGs 55 & 56 and thread the strap through the buckle (Figs 57 & 58). Repeat this on the other side of the vehicle and while pulling towards the rear of the vehicle, slightly tighten one strap and then the other side strap tightening up the top deck. When first tightening the rear straps notice the location of the rear bar sewn into the pocket on the top deck. It needs to be centered on the rear roll bar legs.



**NOTE:** Do not completely tighten these straps yet. They should be holding the top but not pulled as tight as possible. You will do final "tightening" after you install the windows.



The Trusted Source



**NOTICE**

**IMPORTANT:** The top deck **MUST** be centered on the rear of the vehicle for the windows to fit properly.



**Step 10: Installing the Quarter and rear Windows to the top Deck**

To ensure the top is centered on the vehicle you will be installing the two quarter windows and the rear window to the top deck and to each other before securing it to the vehicle body.

**Pro-Install TIP:** To make this as easy as possible, you may have to release the front windshield header (release but not un-hook) and loosen the rear corner straps installed in step 4. This will allow you to line up all window zippers and attachments. The rear corner straps and header will need to be re-tightened/clamped before using the top.

Locate the drivers rear quarter window. Line up the driver's side Quarter window to the zipper on the deck and zip it as shown in FIG's 59, 60 & 61 Repeat this on the passenger side of the vehicle.



Locate the rear window and line up and slide the rear window into the "C" Channel located at the top of the rear portion of the top deck (FIGs 62, 63 & 64).

Once both quarter windows are secured to the top deck, line up the driver's side rear zipper on the Quarter window to the zipper on the rear window

and zip it down a few inches (FIG 65).

Repeat this on the passenger side of the rear window. You may have to lift the quarter window up to secure this second zipper. Once both side zippers are secure, zip the rear window zippers down about half way (Fig 66). You will close these zippers completely at the end of the install.

**NOTICE**

When removing the quarter windows from the Top deck, make sure the zipper is completely out of the "zipper box" before removing the window. See fig 66A



The Trusted Source

**Each Time you remove the rear window:**  
 Completely pull the window out of the “C” Channel before pulling the windows down!  
 Do not “Peel” the window out.



**NOTICE**

There may be times when the “P” extrusion may come out of the “C” Channel ends due to extreme downward pressure. This is normal. If this occurs, slide the “P” extrusion out of the C channel and re install securing the window back into the “C” Channel.



**Step 10: Installing the Top to the Jeep Body**  
 Starting at the driver’s side front, attach the side belt rail into the vehicle body by “rolling” the plastic into the slot (FIG 67).

Once secure move to the rear driver’s side corner and “roll” the plastic into the Jeep body corner belt rail as shown in FIG 68. Repeat this procedure on the passenger side.

**NOTE:** as shown in FIG 69 there is a web loop installed on the side of the quarter window. This is to be used for unhooking the quarter window only and is not designed to be pulled down on for installation!



Repeat the quarter window install on the passenger side of the vehicle. You may have to pull the

corners around towards the front or back of the vehicle to center the top on the vehicle.



Go inside the Jeep and locate the long center bow flap. Wrap this bow flap tightly around the center bow and secure it with the hook and loop fastener (FIGs 70 & 71). you can now reach through the

rear zipper on each side and tighten the corner straps. Alternate tightening to keep the top centered. Seal hook and loop around windows (Figs 72 & 73).



**Step 11A: Installing the Tailgate Bar and Rear Window to the body of the Jeep®**

Take the factory bar and orient the “C”-Channel with the round seal facing down and slide the “C” Channel onto the rear window retainer as shown in FIGs 74 & 75.



The Trusted Source



After sliding the retainer all the way through the "C" Channel, roll the tailgate bar into the mounts with the outside of the fabric facing towards the rear of the Vehicle (Figs 76 & 77).

Once the Tailgate bar is secure, lower zippers on both sides of the rear curtain (FIG 78) and then secure the rear zipper cover flap as shown in Figs 79 & 80.



**Step 11B: Installing the Tailgate Bar and Rear Window to the body of the Jeep®**

Once the Tailgate bar is secure, lower zippers on both sides of the rear curtain (FIG 78) and then secure the rear zipper cover flap as shown in Figs 79 & 80.

**Using your SkyMaster Fastback Soft Top**

**Folding Back the Front Section of your Top:**

To fold back your SkyMaster Soft Top: If driving, stop the vehicle and put in park. Unlatch the front header from the windshield (FIG46, on page 6) Pushing up from the middle, fold back the top.

**WARNING**

Make sure the hook and loop fastener are tightly secured to the center bow after the front sun roof is folded back. Both rear corner straps must also be secure when the top is folded back. These safety measures are designed to secure the top deck to the vehicle and if not adhered to can cause injury, death and a serious accident. Always wear your seat belts when using this product!

**NOTICE**

Before Rolling up the rear window, make sure the glass is clean. Dirt and Debris can cause window scratches when rolled up.

Top Installation is now complete!



The Trusted Source

## Care and Maintenance:

Your QuadraTop is made of the finest materials available but to keep it looking new and for the maximum possible wear, it will need periodic cleaning and basic maintenance. The main threats to your soft top are pollutants, dirt and grime. By keeping your soft top clean you will prolong the life of your top.

We recommend the following to keep your top like new:

**Washing:** The soft top fabric should be washed often using a mild soap, warm water and a soft bristle brush (do not use the brush on the window glass!). You can also use special soft top cleaners available on our website and shown on page 15. Make sure that after cleaning you rinse with clear water to remove all traces of soap.

**Zippers:** Keeping the zipper cleaned and lubricated with a silicone lubricant (see Page 15) will help prevent damage and keep the zippers in a smooth working condition. If zipper opens behind the slider, the slider may have been spread apart. This problem can usually be fixed

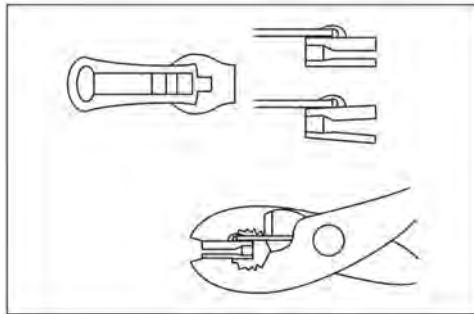

by using an ordinary pair of pliers to bring the sides back into parallel. Return slider to the end of the zipper in the normal Open position. Squeeze lightly at

First and test zipper. If the zipper continues to remain open squeeze more firmly with pliers and try the zipper again. Repeat procedure until your zipper operates correctly.

**Windows:** It is very important that you keep your QuadraTop windows clean! Use a mild soap and water solution to gently clean your windows. NEVER wipe your windows clean with a dry cloth! Dust and dirt on a dry cloth can scratch your windows causing "fogging" and permanent damage. When removing your windows, store them with a towel between the panels/rear windows to protect them from damage. If frost or ice forms on the outside of your windows during the winter, DO NOT use an ice scraper to remove this frost. Over time you will see small micro scratches in your windows which are natural wear and tear. These Micro scratches can be "polished" out using the window polish listed on page 15 (Available at Quadratec.com).

**Water/Fabric:** In the event of seeping through the seams, 3M Scotchgard® may be applied on the inside of the seams to stop the see. Rips in the fabric may be repaired with Bondex® iron on patches. Iron the patches to the Inside of the top, carefully following the Bondex® instructions.

**Snaps:** Keep snaps cleaned and lubricated with silicone to help prevent snaps from sticking to the studs. If a snap does become stuck to a stud, use a screwdriver and GENTLY pry apart to prevent permanent damage to the snap or the top fabric.



The Trusted Source

**Replacement Hardware & Soft Top Accessories available at Quadratec.com**

Please review this set of instructions, and examine your original equipment hardware. Is any hardware missing or damaged? Quadratec offers a full assortment of original equipment hardware and accessories to keep your top looking new and performing at its peak. The following parts and current pricing are available at **Quadratec.com**

- > **Complete Bow Assemblies: #11132.95XX**
- > **Soft Top Emergency Repair Kit: #91083.4201**
- > **Zipper Slick Zipper Lubricant: #91083.4200**
- > **Soft Top Cleaner & Protectant: #91083.110X**
- > **Soft Glass Window Polishes: #91083.11XX**

Don't see what you need on the list? Call for Expert Advice at **800-745-5337**



The Trusted Source

# Quadratec Limited Warranty

## for QuadraTop® Replacement Soft Tops

Your QuadraTop® replacement soft top is covered by the following Limited Warranty provided exclusively by Quadratec, Inc. 1028 Saunders Lane, West Chester, PA 19380.

This **Limited Warranty** is the only warranty made in connection with purchase. Quadratec neither assumes nor authorizes any vendor, retailer or other person or entity to assume for it any other obligation or liability in connection with this product or **Limited Warranty**.

### **What is Covered:**

Subject to the terms, exclusions and limitations herein and with respect only to soft tops first sold in the United States, Quadratec warrants to the initial retail purchaser only that your QuadraTop soft top shall be free of defects in material and workmanship **for a period of 3 years from date of initial retail sale**.

All other warranties are hereby disclaimed, except to the extent prohibited by applicable law in which case any implied warranty of merchantability or fitness for a particular purpose on this product is limited to 3 years from date of initial retail sale. Quadratec reserves the rights to: (a.) require invoice or other proof your soft top is within the terms of this **Limited Warranty** as a condition of warranty service and, (b.) make future revisions to this product and **Limited Warranty** without prior notice or obligation to upgrade your soft top.

### **What is Not Covered:**

Your Quadratec **Limited Warranty** does not cover products or parts Quadratec determines to have been damaged by or subjected to: (a.) installation damage, alteration, modification, failure to maintain or attempted repair or service by anyone not authorized by Quadratec, (b.) normal wear and tear, cosmetic damage or damage from water immersion, (c.) Acts of God, accidents, misuse, negligence, inadequate mounting or impact with vehicle(s), obstacles or other aspects of the environment, (d.) theft, vandalism or other intentional damage.

**Remedy Limited to Repair/Replacement:** **The exclusive remedy provided hereunder shall, upon Quadratec inspection and at Quadratec's option, be either repair or replacement of product or parts (new or refurbished) covered under this Limited Warranty.** Customers requesting warranty consideration on QuadraTop soft top should first contact Quadratec to obtain a RGA number (610-701-3336). All labor, removal, shipping and installation costs are customer's responsibility.

### **Other Limitations - Exclusion of Damages - Your Rights Under State Law:**

In consideration of the purchase price paid, neither Quadratec nor any independent Quadratec distributor/licensee are responsible for any time loss, rental costs, or for any incidental, consequential, punitive or other damages you may have or incur in connection with any part or product purchased. Your exclusive remedy hereunder for covered parts is repair/replacement as described above.

This **Limited Warranty** gives you specific rights. You may also have other rights that vary from state to state. For example, some states do not allow limitations of how long an implied warranty lasts and/or do not allow the exclusion or limitation of incidental or consequential damages, so the limitations and exclusions herein may not apply to you.

The terms Quadratec®, QuadraTop®, Essentials® and Essential® are Registered Trademarks of Quadratec Inc. Registered in U.S. Patent and Trademark Office.

©Quadratec, Inc. 2020. All Rights Reserved. Version 11.7.20

Part #12999.1000



The Trusted Source