

Quadratec® Mid-Width Rear Bumper

Installation Manual for 2007 - 2018 Wrangler (JK)
#12057.0250



⚠ WARNING ⚠

TO REDUCE RISK OF SERIOUS INJURY OR PROPERTY DAMAGE: READ ALL SAFETY MESSAGES AND UNDERSTAND ALL INSTRUCTIONS AND PROCEDURE *NOTICES* BEFORE ATTEMPTING TO INSTALL OR USE THIS PRODUCT.

⚠ CAUTION ⚠

RISK OF EYE INJURY! SAFETY GLASSES MUST BE WORN AT ALL TIMES WHILE INSTALLING OR MAINTAINING THIS PRODUCT. TORQUE AND RECHECK FASTENERS AFTER 250 MILES AND FREQUENTLY THEREAFTER. INSPECT BUMPER BEFORE USE. DO NOT USE IF DAMAGED.

NOTICE

CHECK STATE AND LOCAL HIGHWAY SAFETY LAWS REGARDING PERMITTED BUMPER TYPES AND HEIGHTS.

NOTICE

BUMPERS ARE HEAVY AND WE STRONGLY SUGGEST THE ASSISTANCE OF AN ABLE-BODIED ASSISTANT DURING LIFTING AND INSTALLATION OF YOUR BUMPER.

Quadratec®
The Jeep® Experts

A Few Words About Product Safety:

Your Quadratec® Rear Bumper is intended to enhance the utility and enjoyment of your off road capable vehicle. Before installation, please review the following safety information and installation recommendations.

Throughout these instructions important safety information is generally preceded by one of three signal words indicating the relative risk of injury, property damage or adverse consequence. **The signal words mean:**

⚠ WARNING ⚠	a hazardous situation which, if not avoided, could result in death or serious injury. You CAN be KILLED or SERIOUSLY HURT if you don't follow instructions.
⚠ CAUTION ⚠	a hazardous situation which, if not avoided, could result in minor or moderate injury. You CAN be moderately HURT and also may suffer property damage if you don't follow instructions.
NOTICE	Careful attention is required to this instruction or operation but does generally not relate to personal injury. Damage to your Quadratec® product or other property may result if you don't follow instructions.

Before You Begin Installation:

Congratulations on your purchase of Quadratec® Rear Bumper for your Jeep® Wrangler. This custom fit Bumper has been designed for long life and a great look. Though constructed of only the finest materials, this bumper must be maintained to keep its look while performing under the toughest conditions. Please see page 7 for important care and maintenance tips to keep your bumper

looking like new. When unpacking, check to make sure all parts are included and not damaged due to shipping. If any part is missing or broken, please call Customer Service at 800-745-6037 as soon as possible.

Thank you again for your purchase and let's start the installation process.

NOTICE	AS YOU UNPACK YOUR REAR BUMPER, BE CAREFUL NOT TO SCRATCH THE FINISH WITH A KNIFE OR RAZOR. WE SUGGEST PLACING THE UNPACKED BUMPER BACK INTO THE ORIGINAL BOX SO IT DOES NOT GET SCRATCHED BEFORE THE INSTALLATION BEGINS.
NOTICE	ACCESSORY REAR BUMPERS ARE HEAVY AND WE STRONGLY SUGGEST THE ASSISTANCE OF AN ABLE-BODIED ASSISTANT DURING LIFTING AND INSTALLATION OF YOUR BUMPER.

⚠ CAUTION ⚠	READ ALL SAFETY MESSAGES AND ALWAYS WEAR SAFETY GLASSES WHEN WORKING WITH TOOLS.
--------------------	---



JK Rear Bumper Parts & Tools:

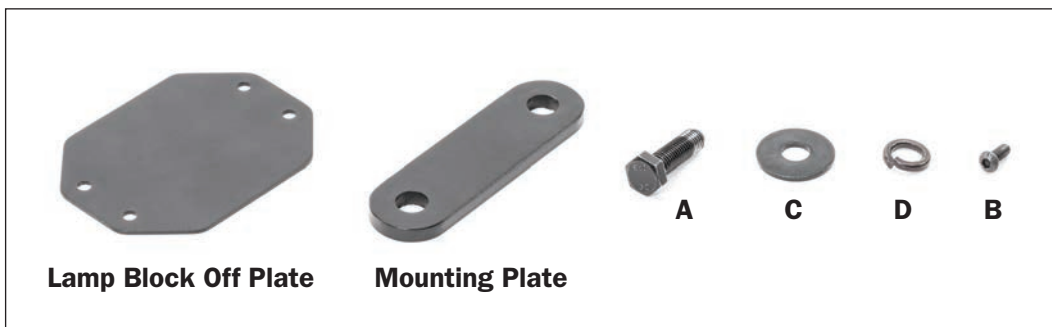
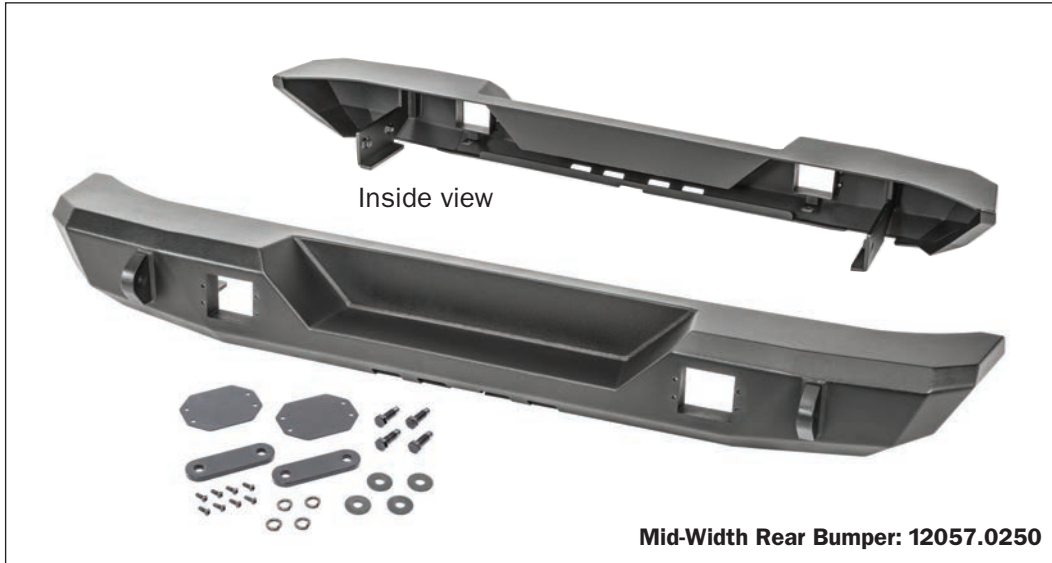

KIT CONTENTS LIST:

- Mid-Width Rear Bumper (1)
- Bumper Mounting Plates (2)
- Reverse Lamp Block Off Plates (2)

- A.) M12 x 40mm Hex Bolts (4)
- B.) M6 x 16mm Button Head Bolts (8)
- C.) M12 Flat Washers (4)
- D.) 12mm Lock Washers (4)

REQUIRED TOOLS:

- Safety Glasses
- 16mm & 18mm Sockets
- Ratchet Driver
- 4mm Hex/Allen Wrench Key
- Torque Wrench (ft lbs)

JK Rear Bumper Installation:

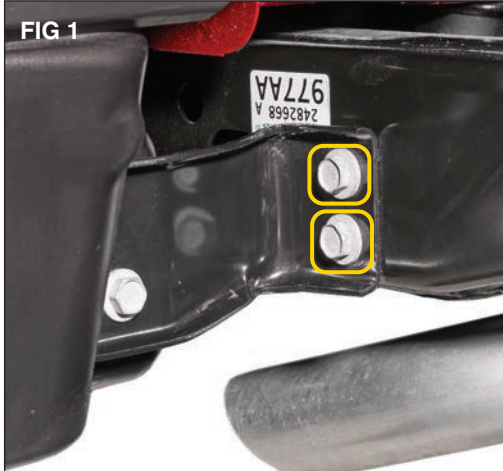

Put on safety glasses. Open tailgate and swing it, and spare tire out of the way. Remove the (4) M10 bolts (2 per side) that attach the rear bumper brackets to frame using a 16mm socket. (FIG1)

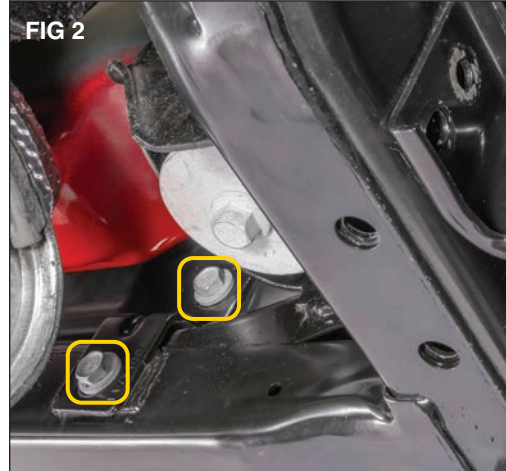

Remove the (4) M10 bolts holding the rear bumper support brackets to the frame using a 16mm socket. (see FIG2) Remove the brackets and bumper from the vehicle.

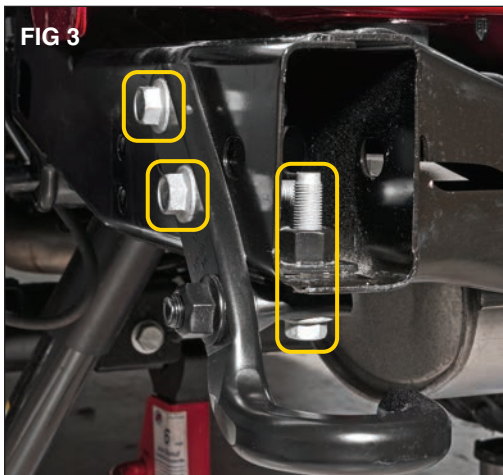

If equipped, remove the three bolts attaching the original recovery hook using a 18mm socket. (FIG3) Recovery hook will not be reused with the new rear bumper.



The Mid Width bumper is designed to accept two types of reverse lights if desired. The lamps will need to be mounted before bumper installation. If not installing lights, you may install the supplied block off plates as shown using the 6mm button Head bolts (B). (FIG 4)

JK Rear Bumper Installation:

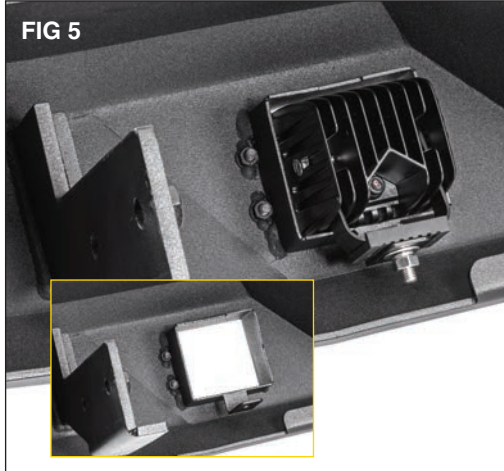

Pedestal Mounted Reverse Lamps: If installing pedestal mounted “Cube” style lamps, mount them as shown, using the 6mm Button Head bolts (B). (FIG 5)



Flush Mounted Reverse Lamps: If installing flush mounted “Cube” style lamps, mount them as shown, using the 6mm Button Head bolts (B). (FIG6)

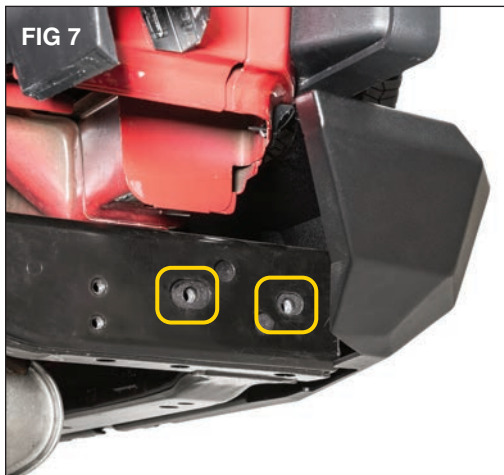

With assistance from another person, and with the tailgate partially open lift the bumper and gently slide it into the frame rails. Align the threaded holes with the holes in the frame rail. (FIG7)



While holding the bumper support plates in place, thread the 12 x 40mm Bolts (A), lock washer (D), and flat washer (C) through the plates, frame rail and into the bumper using a 18mm socket. (FIG8)

JK Rear Bumper Installation:



Adjust the bumper to the desired height. (FIG9) and Torque M12 Bolts to 66 ft lbs.



Bumper install is now complete. The Rear Bumper is designed to be compatible with the VersaHitch® (#12015.1002)



and also the standard 2" Quadratec receiver hitch (#12015.1000) as shown above.

JK Rear Bumper Results & Care:



Your Bumper has been designed and manufactured to provide years of use. However, like any product, general maintenance is required to keep it looking new.

Since the bumper is located on the rear of the vehicle, it is subject to potential rock chips and other debris potentially causing portions of the paint to chip off. We recommend using a textured or gloss black spray paint sprayed on a piece of cardboard and Q-Tip to gently fill in these chips. This will prevent any rust from forming.

On all bumpers there is a chance of some surface rust showing over time due to metal particles being embedded in the paint. This surface rust is easily removed by a non-abrasive cleaner/polish and a soft bristle brush (not a metal brush!).

For bumpers with a textured finish, wash only with soapy water and avoid other waxes and polishes.

Quadratec
The Jeep Experts

Quadratec® Exclusive Three Year Limited Warranty

Your Quadratec® branded accessories are covered by the following **Limited Warranty** provided exclusively by Quadratec, Inc., 1028 Saunders Lane, West Chester PA 19380.

This **Limited Warranty** is the only warranty made in connection with your purchase. Quadratec neither assumes nor authorizes any vendor, retailer or other person or entity to assume for it any other obligation or liability in connection with this product or **Limited Warranty**. This **Limited Warranty** does not apply and is not cumulative to any accessory or part distributed by Quadratec for which the Manufacturer provides a separate written warranty.

What is Covered: Subject to the terms, exclusions and limitations herein and with respect only to Quadratec branded accessories first sold in the United States, Quadratec warrants to the initial retail purchaser only that your Quadratec accessory shall be free of defects in material and workmanship: **for a period of three (3) years from date of retail purchase.**

This **Limited Warranty** is not assignable and shall terminate upon sale of the vehicle upon which the Quadratec accessory is installed or other transfer third persons.

All other warranties are hereby disclaimed, except to the extent prohibited by applicable law in which case any implied warranty of merchantability or fitness for a particular purpose on this product is limited to 3 year from date of initial retail sale. Quadratec reserves the rights to: (a.) require invoice or other proof your accessory is within the terms of this **Limited Warranty** as a condition of warranty service and, (b.) make future revisions to this product and **Limited Warranty** without prior notice or obligation to upgrade your product.

What is Not Covered:

Your Quadratec **Limited Warranty** does not cover products or parts Quadratec determines to have been damaged by or subjected to:

(a.) installation damage, alteration, modification, combination with other parts, failure to maintain or improper repair or service, (b.) normal wear & tear, cosmetic damage or damage from moisture or water immersion, (c.) Acts of God, accidents, misuse, negligence, inadequate mounting or impact with vehicle(s), obstacles or other aspects of the environment, (d.) theft, vandalism or other intentional damage.

Remedy Limited to Repair/Replacement:

The exclusive remedy provided hereunder shall, upon Quadratec inspection and at Quadratec's option, be either repair or replacement of product or parts (new or refurbished) covered under this Limited Warranty. Customers requesting warranty consideration should first contact Quadratec to obtain a RGA number (610-701-3336). All labor, removal, shipping and installation costs are customer's responsibility.

Other Limitations - Exclusion of Damages - Your Rights Under State Law:

In consideration of the purchase price paid, neither Quadratec nor any independent Quadratec distributor/licensee are responsible for any time loss, rental costs, or for any incidental, consequential, punitive or other damages you may have or incur in connection with any part or product purchased. Your exclusive remedy hereunder for covered parts is repair/replacement as described above.

This **Limited Warranty** gives you specific rights. You may also have other rights that vary from state to state. For example, some states do not allow limitations of how long an implied warranty lasts and/or do not allow the exclusion or limitation of incidental or consequential damages, so the limitations and exclusions herein may not apply to you.

©Quadratec, Inc. 2020. All Rights Reserved.
A4 Version 6.29.20

Instructions Part #12999.3124

