



# HARD TOP JEEP GLADIATOR

Dessus solide

Tapa dura

www.mopar.com

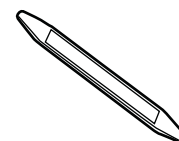
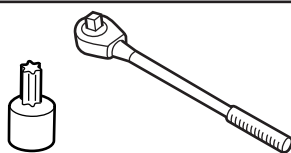
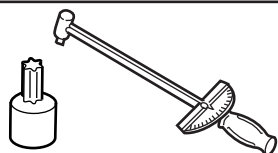
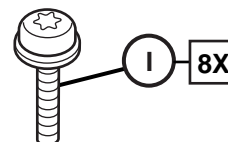
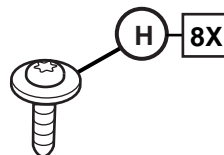
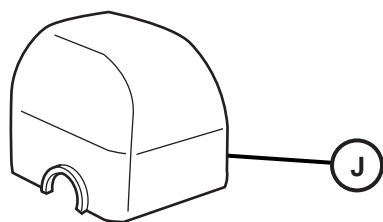
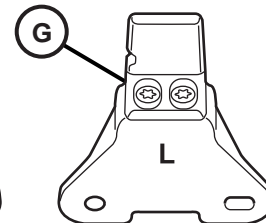
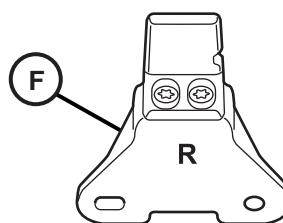
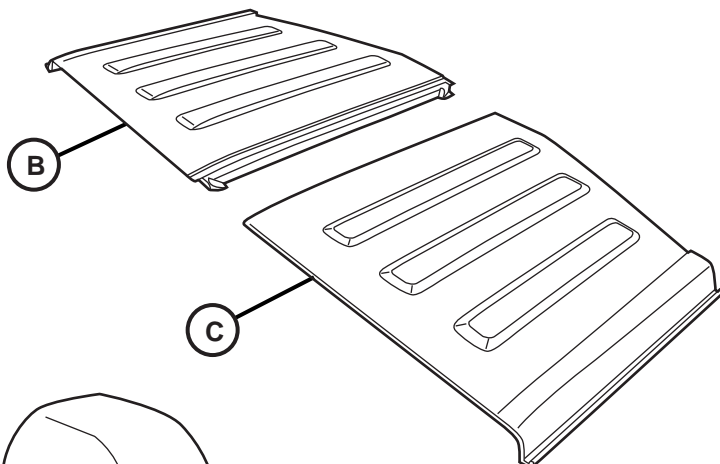
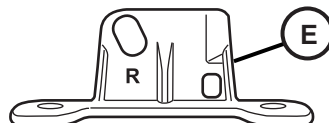
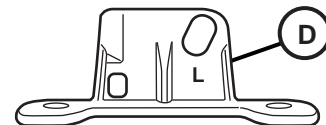
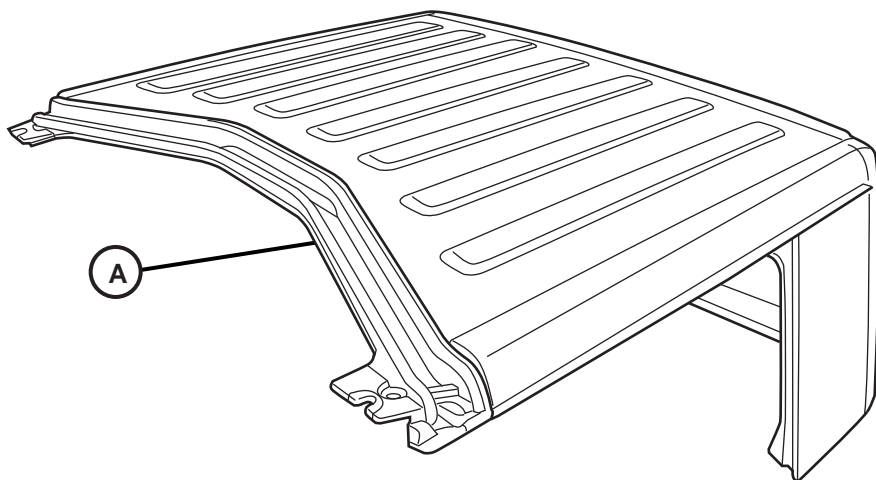

**NOTE: IF NECESSARY, REMOVE SOFT TOP BEFORE PROCEEDING**

Remarque: Si nécessaire, retirez la capote avant de continuer  
Nota: si es necesario, retire la parte superior suave antes de continuar

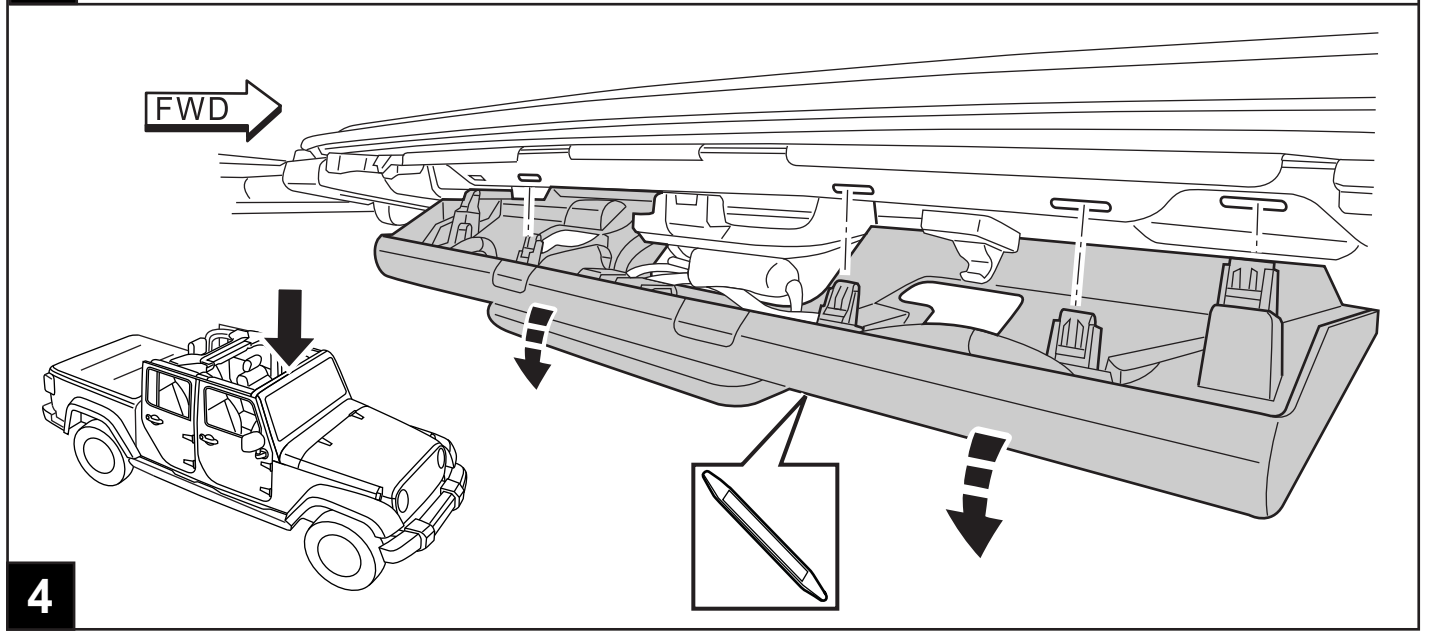
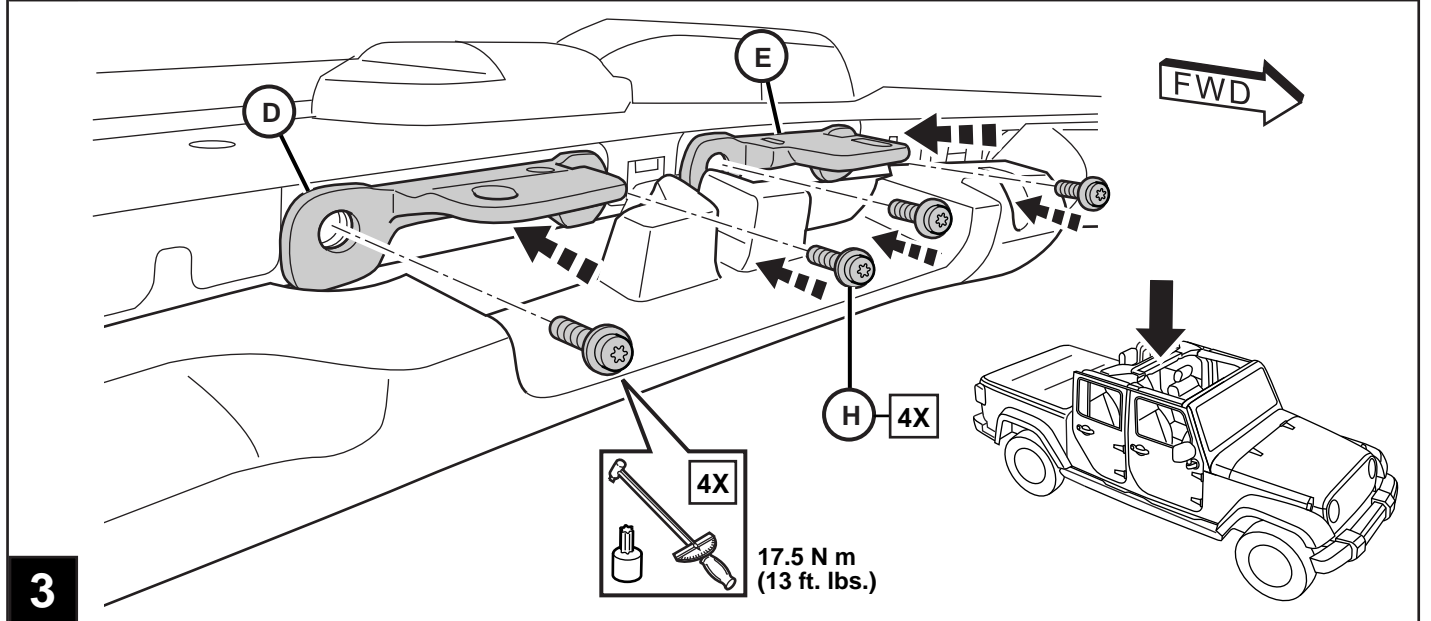
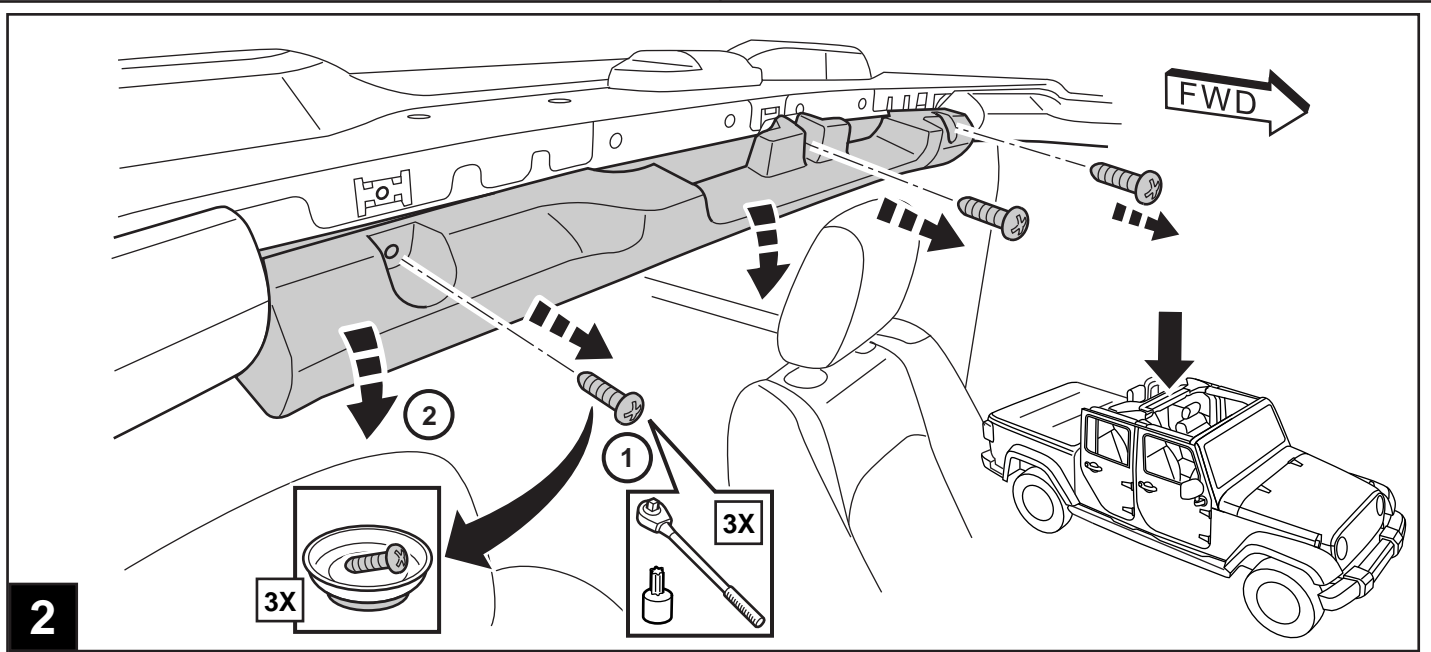

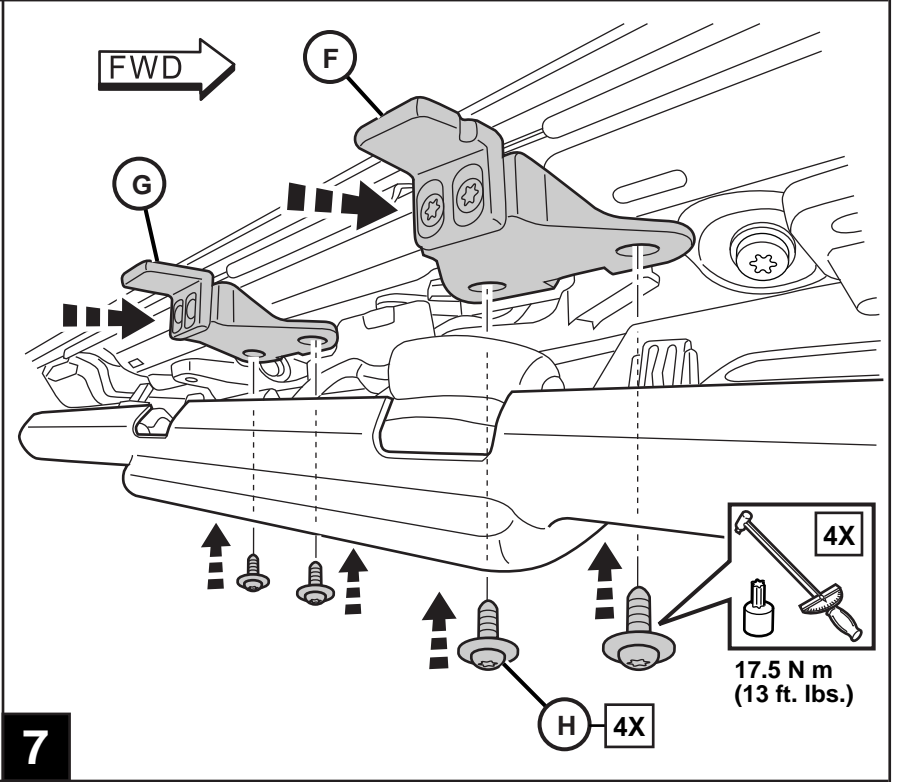
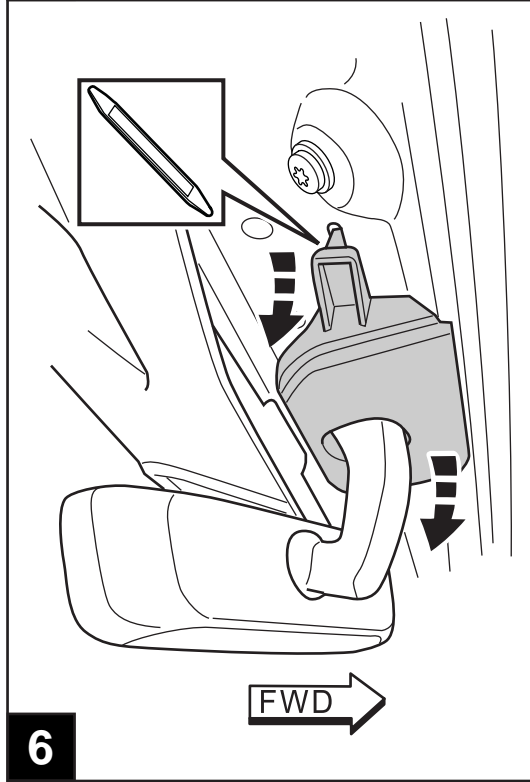
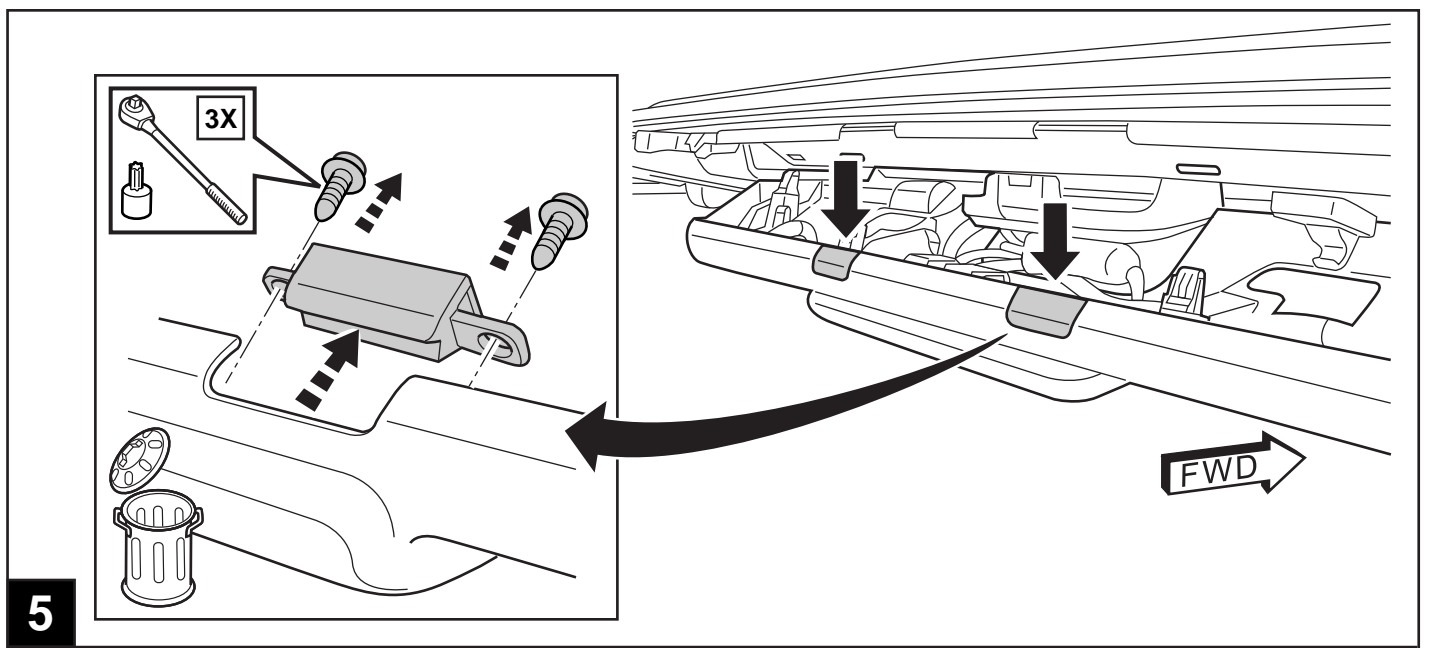

REVERSE STEPS 2, 4 AND 6 TO REINSTALL TRIM PANELS

Inversez les étapes 2, 4 et 6 pour réinstaller les composants du véhicule

Invierta los pasos 2, 4 y 6 para reinstalar los componentes del vehículo

8

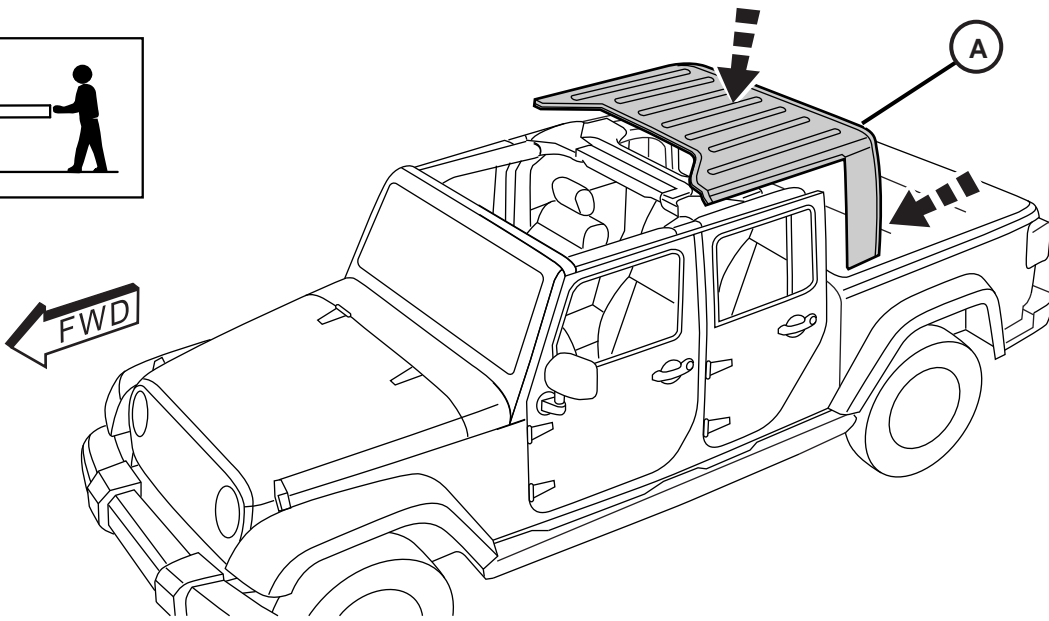
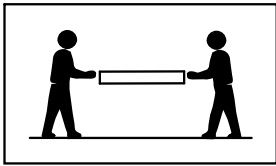

9

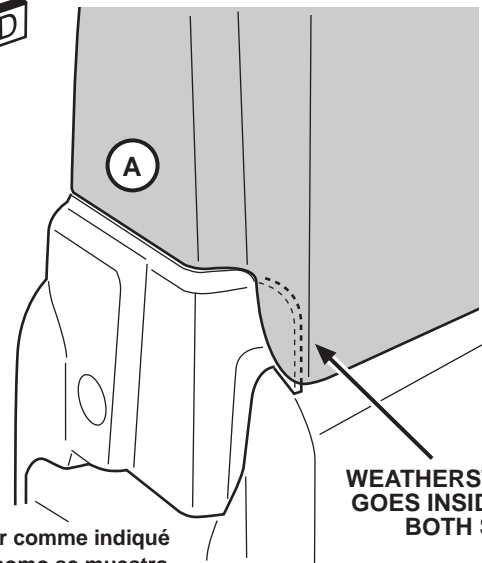
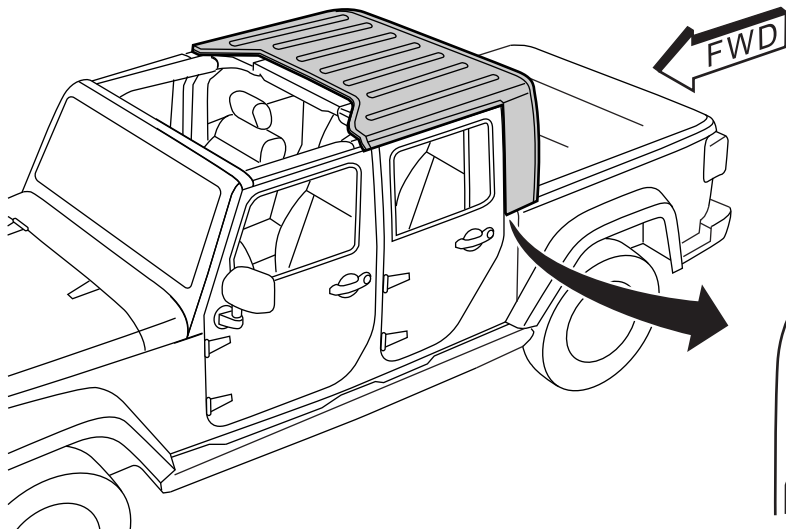

WEATHERSTRIP EDGE GOES INSIDE TOP ON BOTH SIDES

10

Le bord du joint en caoutchouc va à l'intérieur comme indiqué  
El borde del sello de goma va hacia adentro como se muestra

10 N·m (+/- 2.5 N·m)  
88 in lb (+/- 22 in lb)

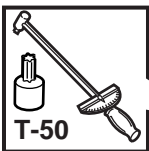

T-50

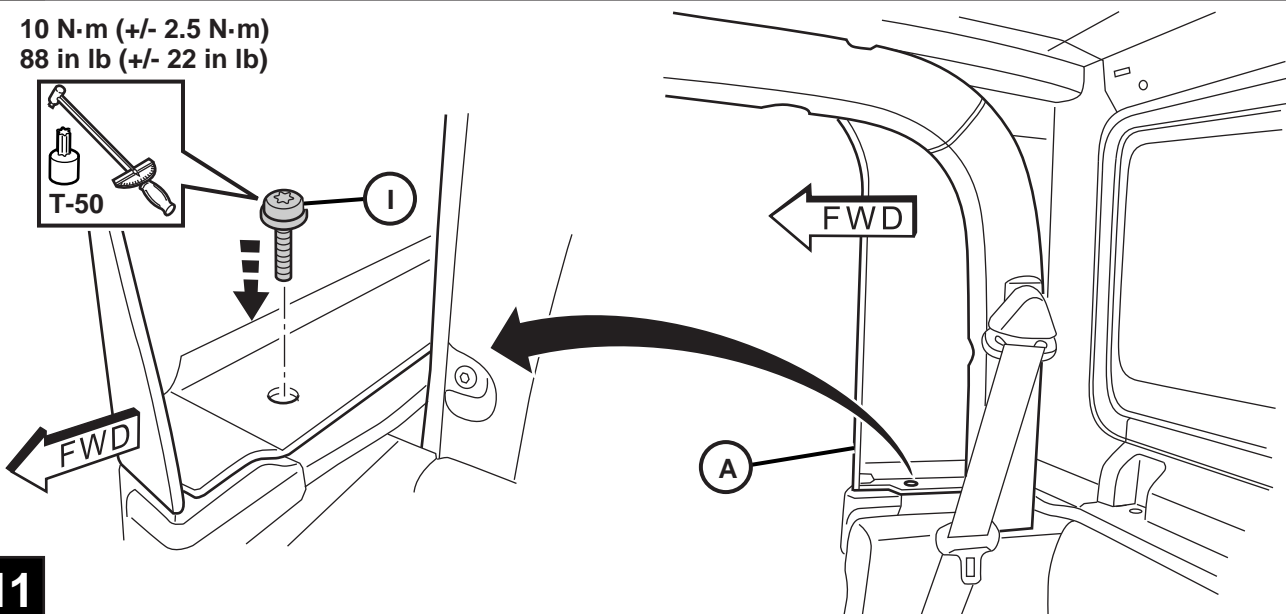

11

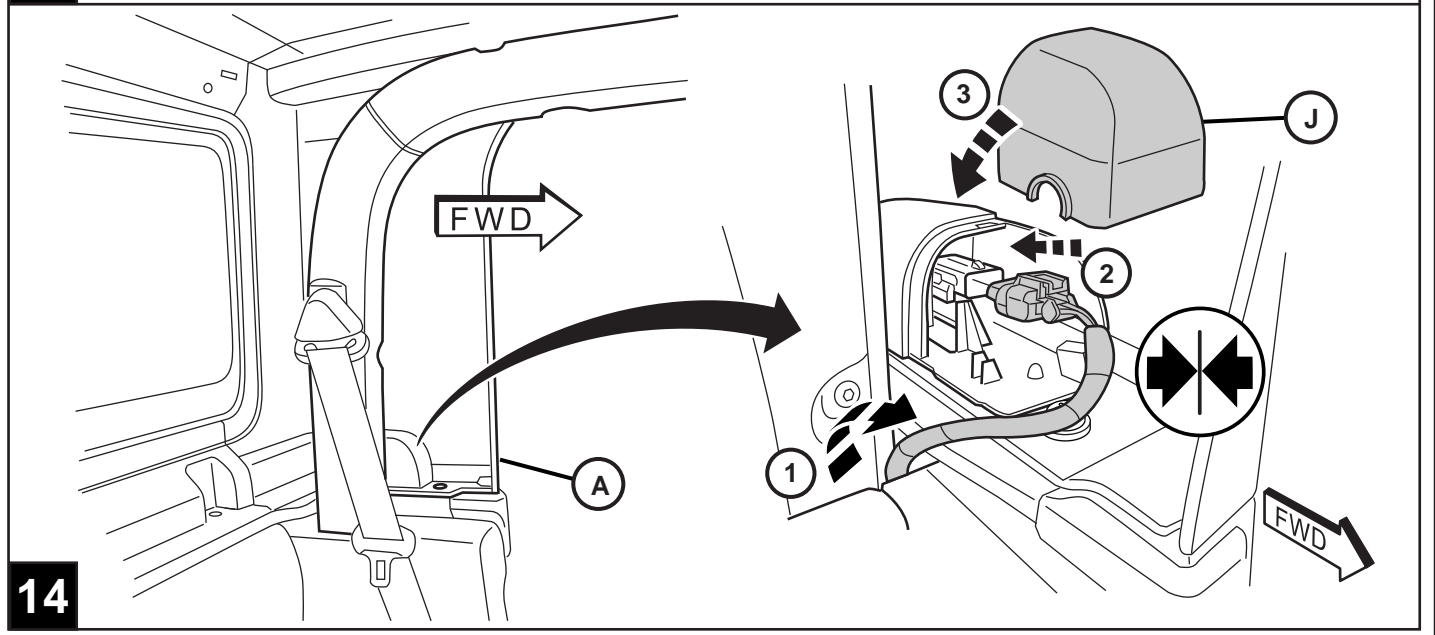
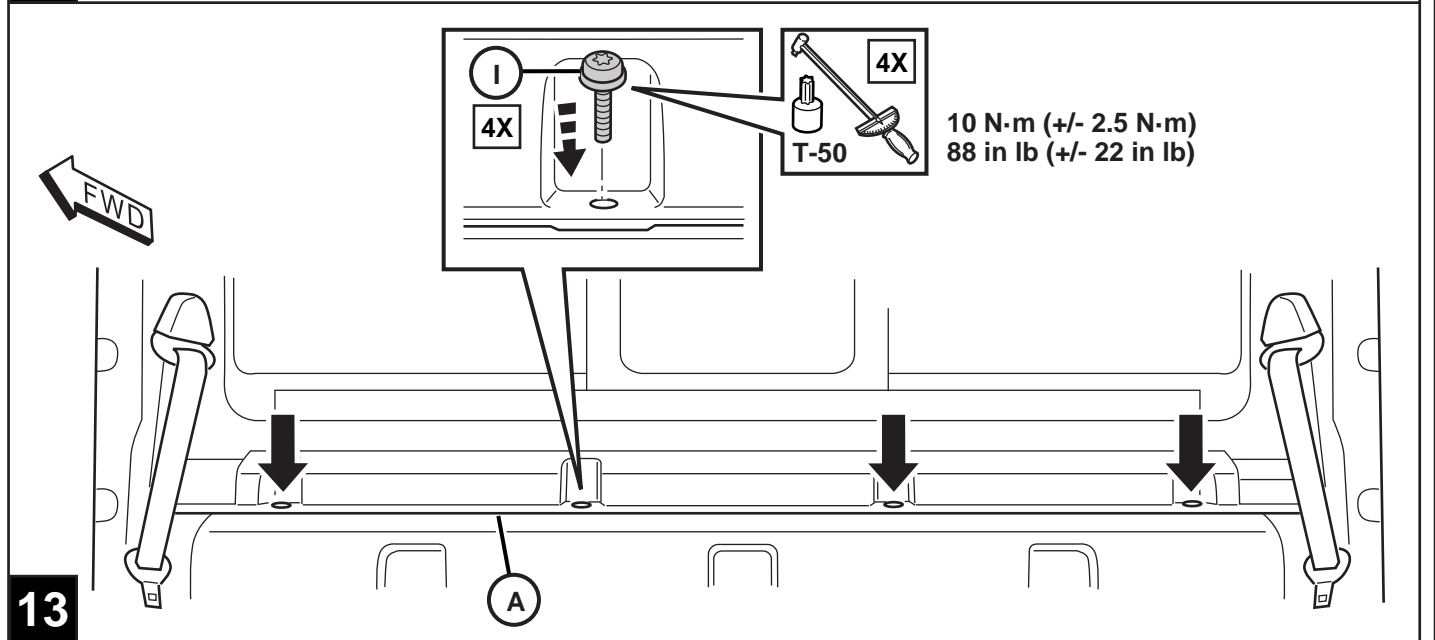
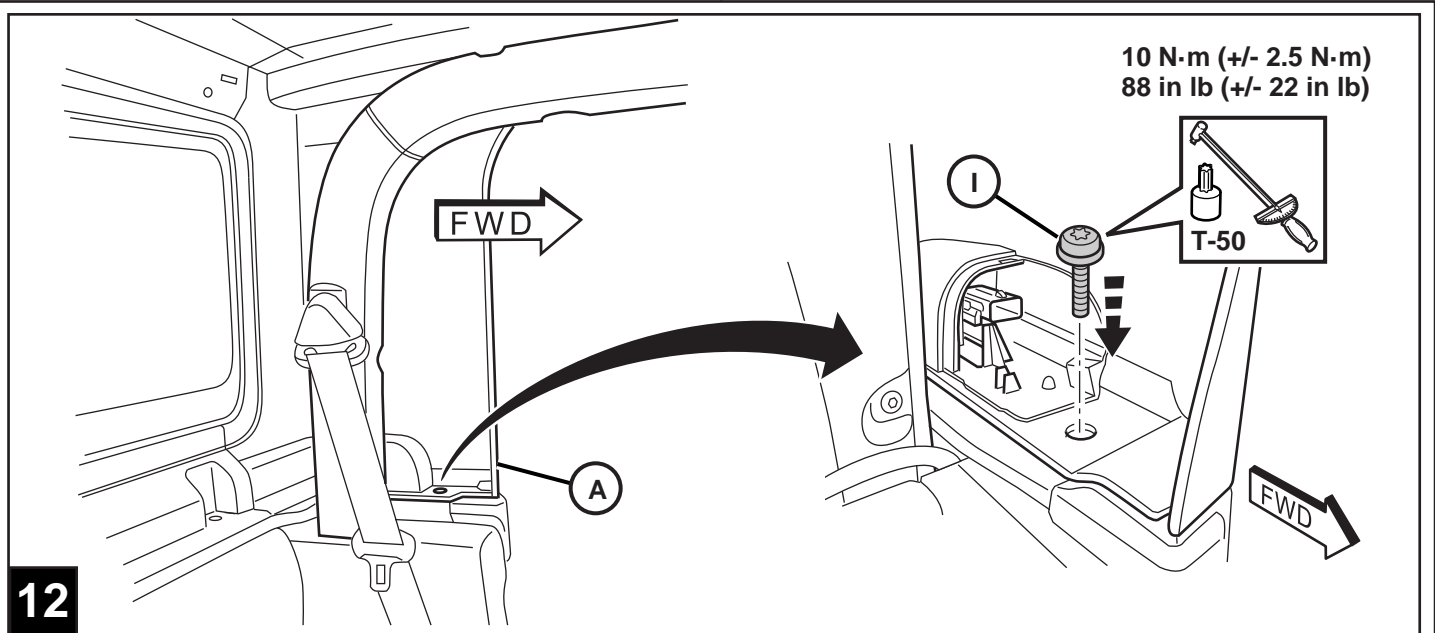

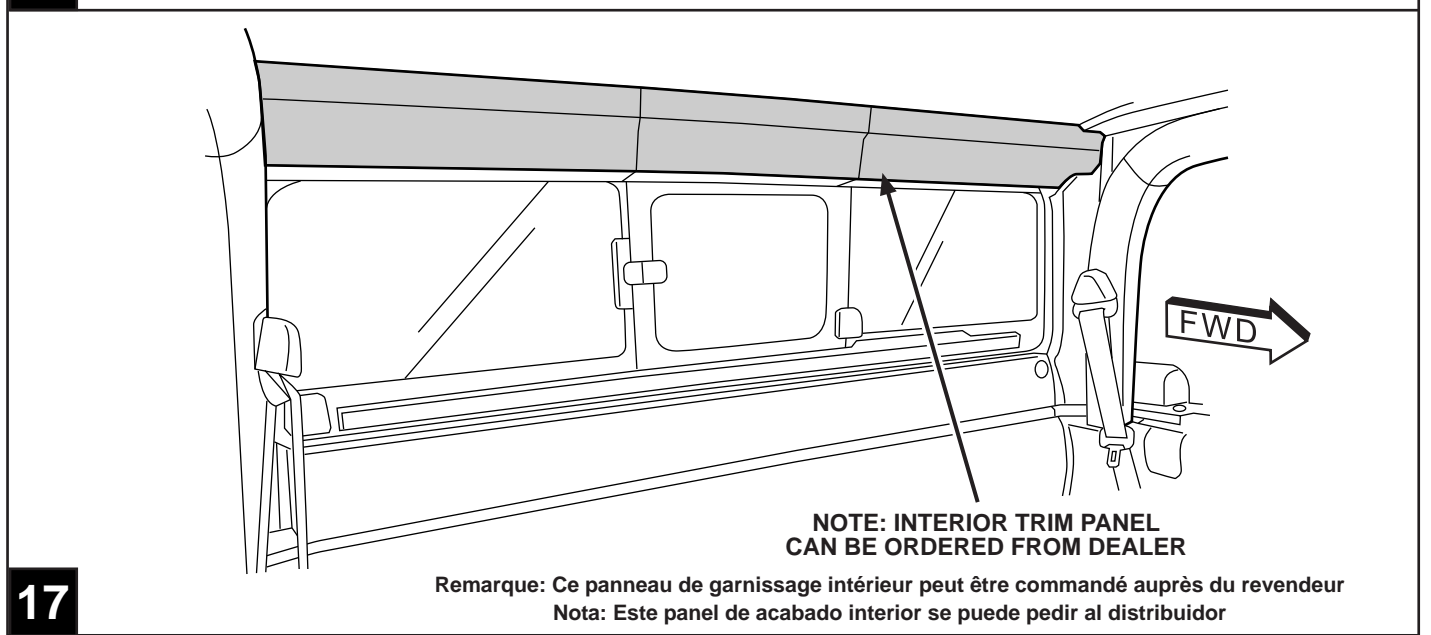
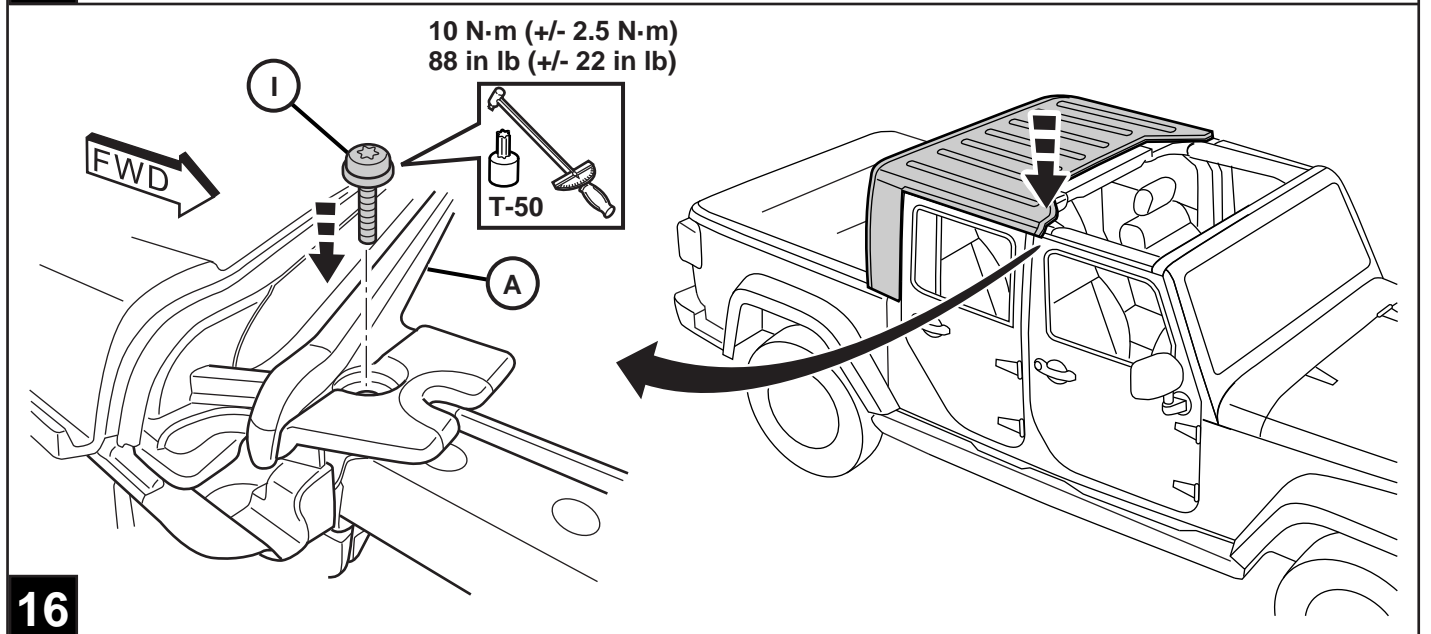
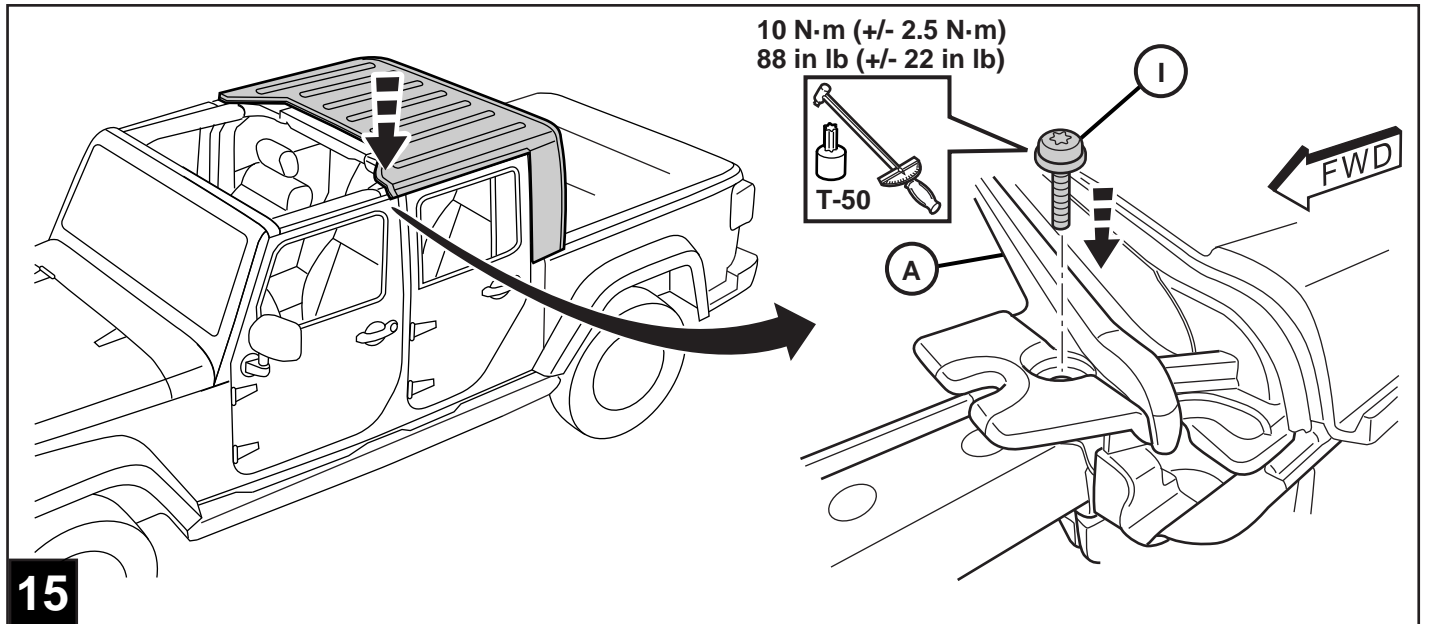

18

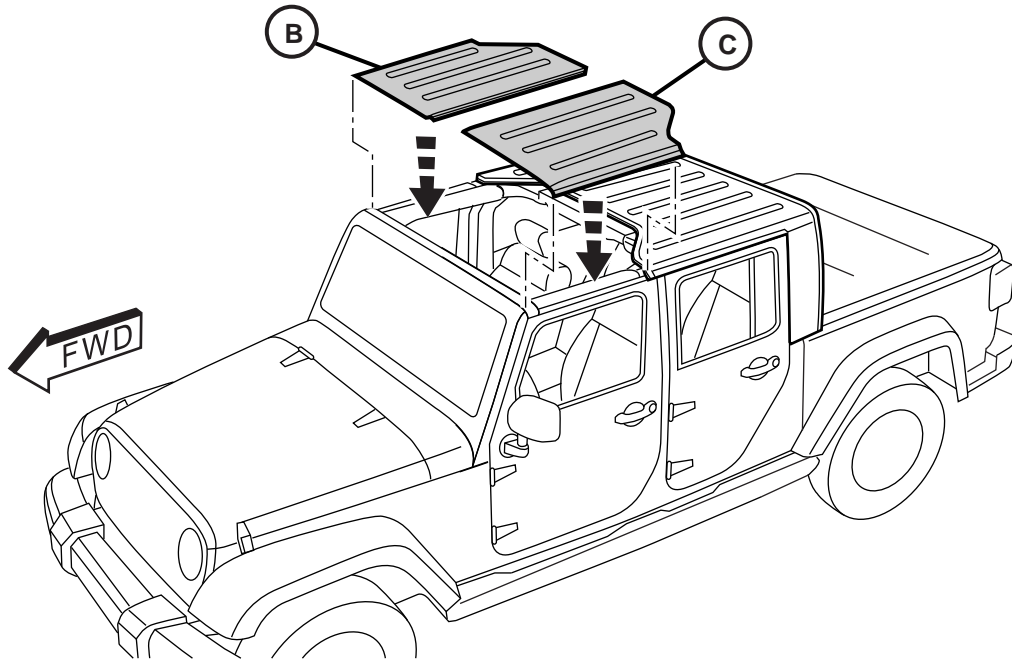

19

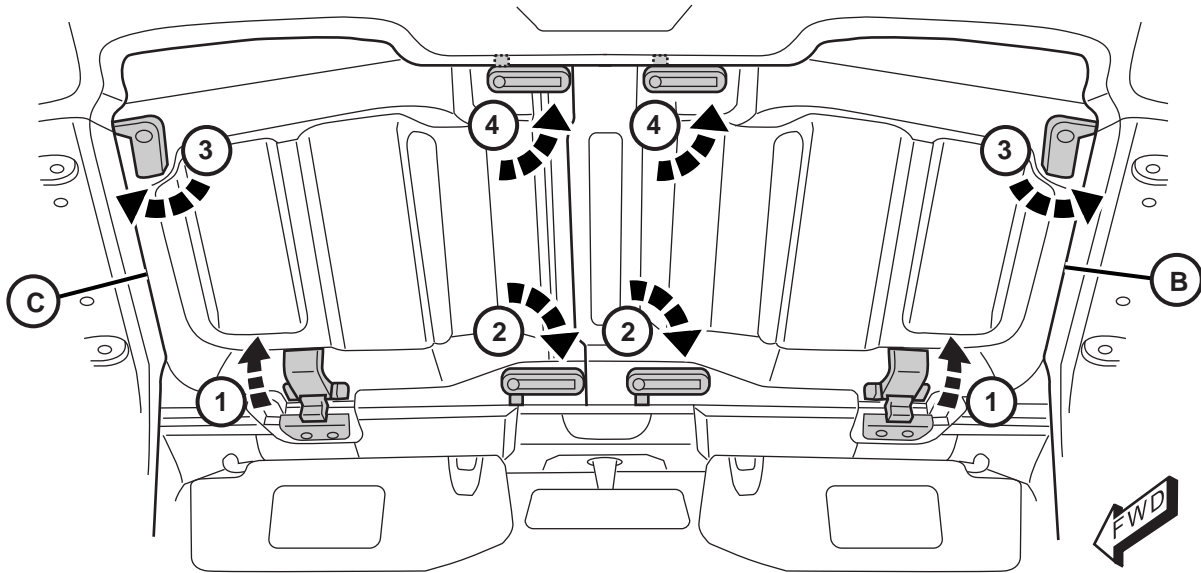

**FOLLOW THE INSTRUCTIONS ON THE FOLLOWING PAGES  
TO CHECK THE FIT OF THE FREEDOM PANELS**

Suivez les instructions sur les pages suivantes pour vérifier l'ajustement des panneaux supérieurs

Siga las instrucciones en las páginas siguientes para verificar el ajuste de los paneles superiores

20

## FREEDOM PANEL FIT INSTRUCTIONS

The following procedure provides instructions to properly fit the FREEDOM PANELS, also called (LH and RH) modular top panels.

This procedure will require a MOPAR essential tool (2022300230)

2022300230 – Gauges, Clearance Measurement, Non-Metallic



Disassemble the gauges, then reassemble to have only 8mm of gauges (1) as shown.

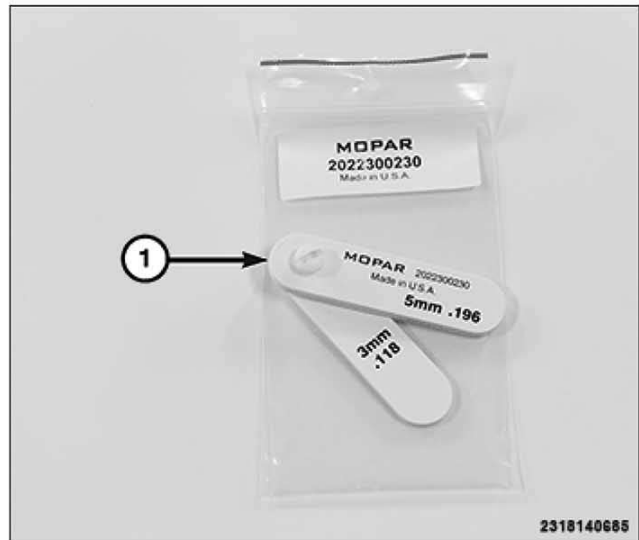

This graphic shows Freedom Panels (1) that do not meet the gap specification of 8mm.

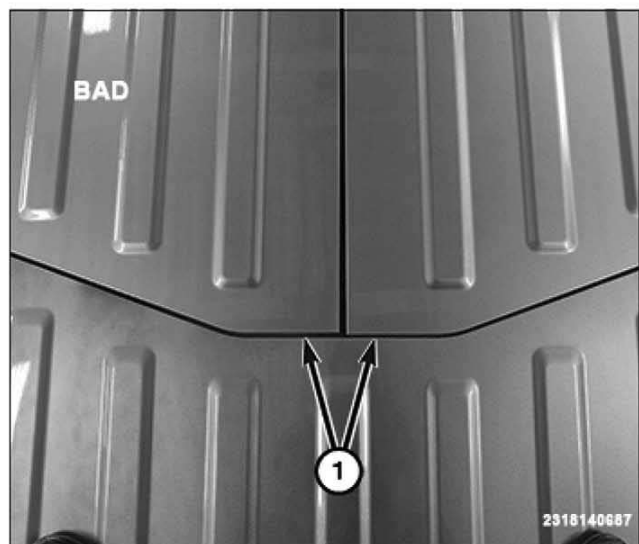



This graphic shows Freedom Panels that do meet the gap specification of 8mm at the four areas of measurement.

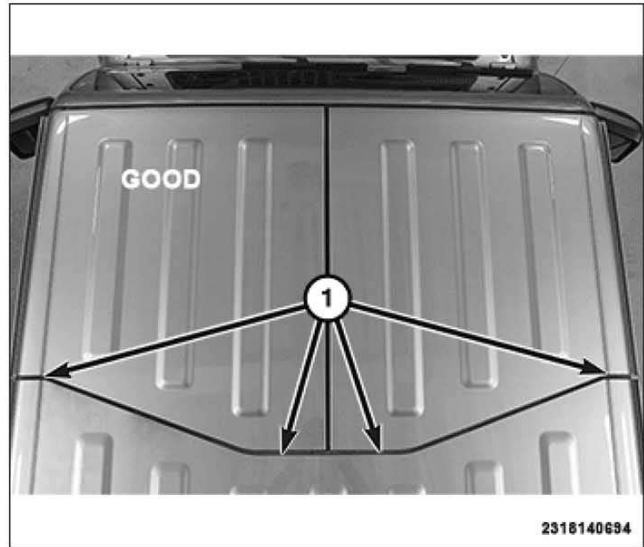

1. Remove the LH modular top panel.
2. Lower the RH visor (2), unhook and swing it forward to access the front receiver.
3. Open the RH receiver clamp (3).
4. Remove the felt patches from the bolt heads on the RH front receiver bracket, then **LOOSEN** the two receiver bracket bolts (1). Feel the bracket by hand to make sure it will move for adjustment.

**NOTE:** Save the felt patches to put back on the bolt heads.

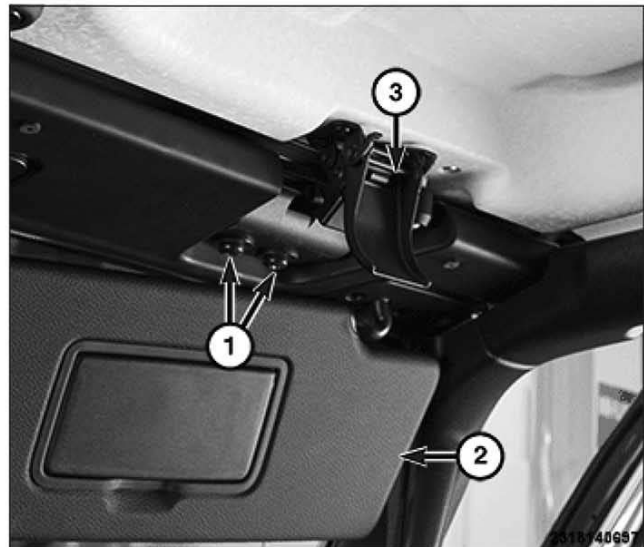

5. Open the remaining clamps (1) on the RH modular top panel.

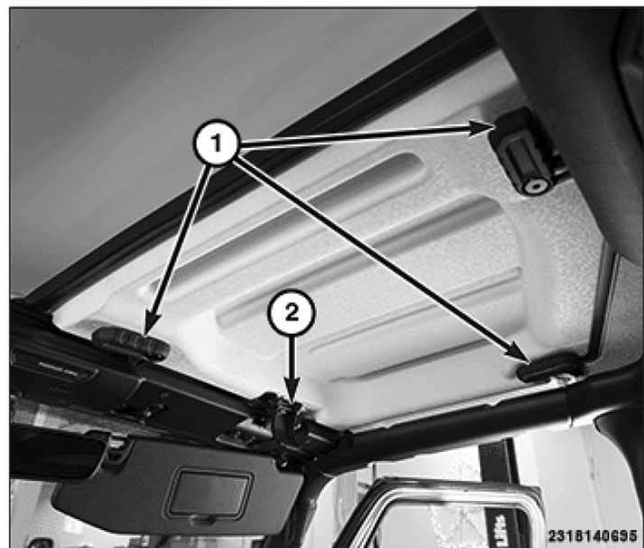

6. Position the RH modular top panel (2) till the 8mm gap gauges (1) will fit firmly between the rear hard top panel and the RH modular top panel, on the RH side of the vehicle just above the B-pillar and at the center of the vehicle.
7. When the 8mm gap has been achieved, close all the clamps, **EXCEPT** the front center clamp. Check that the panel did not move.

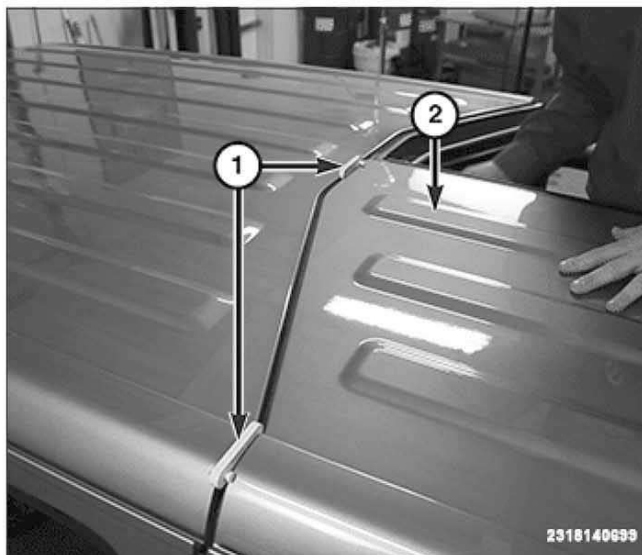

8. Tighten the **OUTBOARD** hard top front receiver bracket bolt to the proper (Torque Specifications).
9. Tighten the **INBOARD** hard top front receiver bracket bolt to the proper (Torque Specifications).
10. Close the front center RH modular top clamp (3).

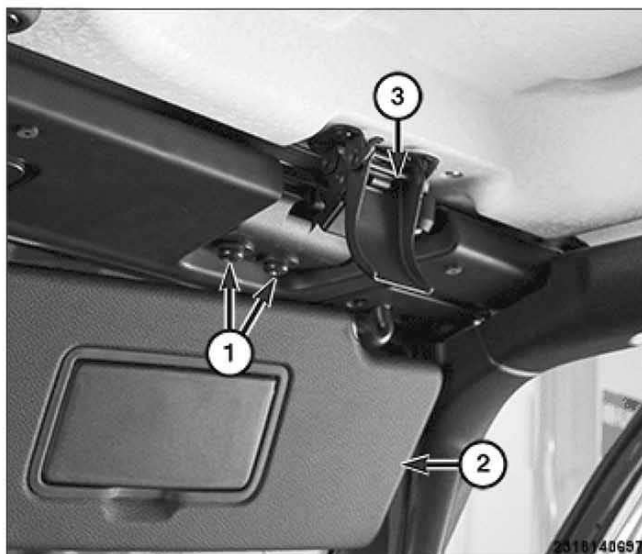

11. Install the LH modular top panel onto the vehicle, **do not close any clamps**.
12. Lower the LH visor (1), unhook and swing it forward to access the front receiver.
13. Remove the felt patches from the bolt heads on the LH front receiver bracket, then **LOOSEN** the two receiver bracket bolts (2). Feel the bracket by hand to make sure it will move for adjustment.

**NOTE:** Save the felt patches to put back on the bolt heads.

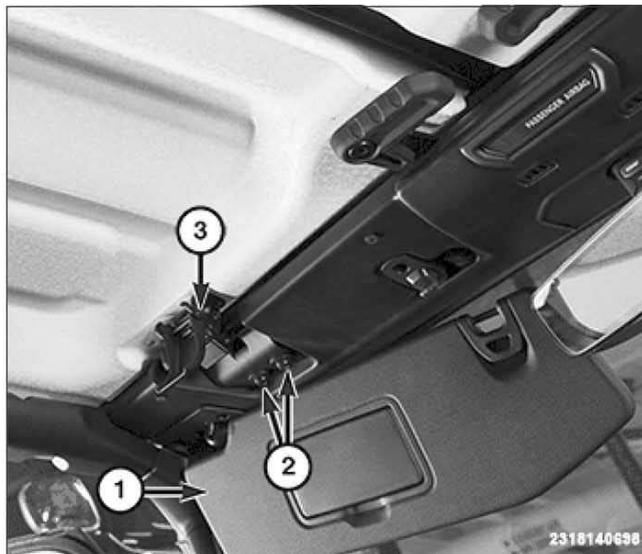

14. Position the LH modular top panel (2) till the 8mm gap gauges (1) will fit firmly between the rear hard top panel and the LH modular top panel, on the LH side of the vehicle just above the B-pillar and at the center of the vehicle.

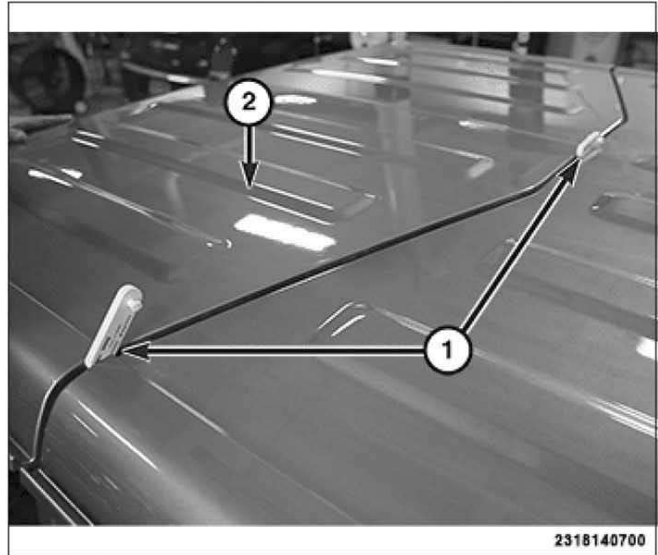

15. When the 8mm gap has been achieved, close all the clamps (1), **EXCEPT** the front center clamp (2). Check that the panel did not move.

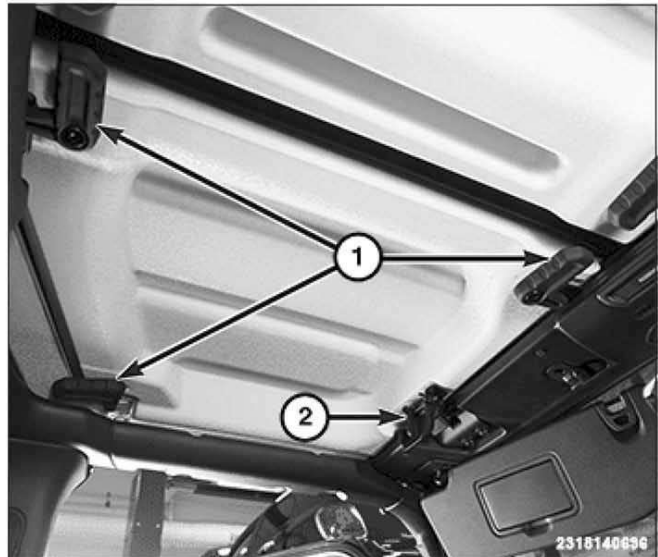

16. Tighten the **OUTBOARD** hard top front receiver bracket bolt to the proper [Torque Specifications](#).  
 17. Tighten the **INBOARD** hard top front receiver bracket bolt to the proper [Torque Specifications](#).  
 18. Close the front center LH modular top clamp (3).  
 19. Place the felt patches over the bolt heads.  
 20. Return the visors to the original position.  
 21. Using an 8mm gap gauge, verify the gaps. If the gaps are not correct, repeat the procedure.

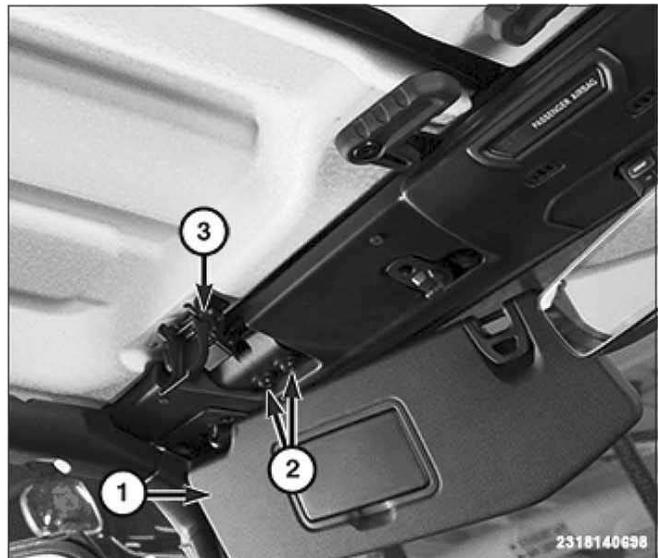

### FREEDOM PANEL FLUSH FIT

