



Signature Series



JEEP JL/JT SIGNATURE
FRONT BUMPERS
INSTALL INSTRUCTIONS



WEB LINK: <http://lodoffroad.com/assets/pdfs/JL18FBSSINS.pdf>

VERIFY YOU HAVE ALL THE COMPONENTS BEFORE STARTING THE INSTALLATION. REFER TO THE ENGINEERING DRAWINGS AT THE END OF THIS DOCUMENT FOR A COMPLETE PARTS LIST

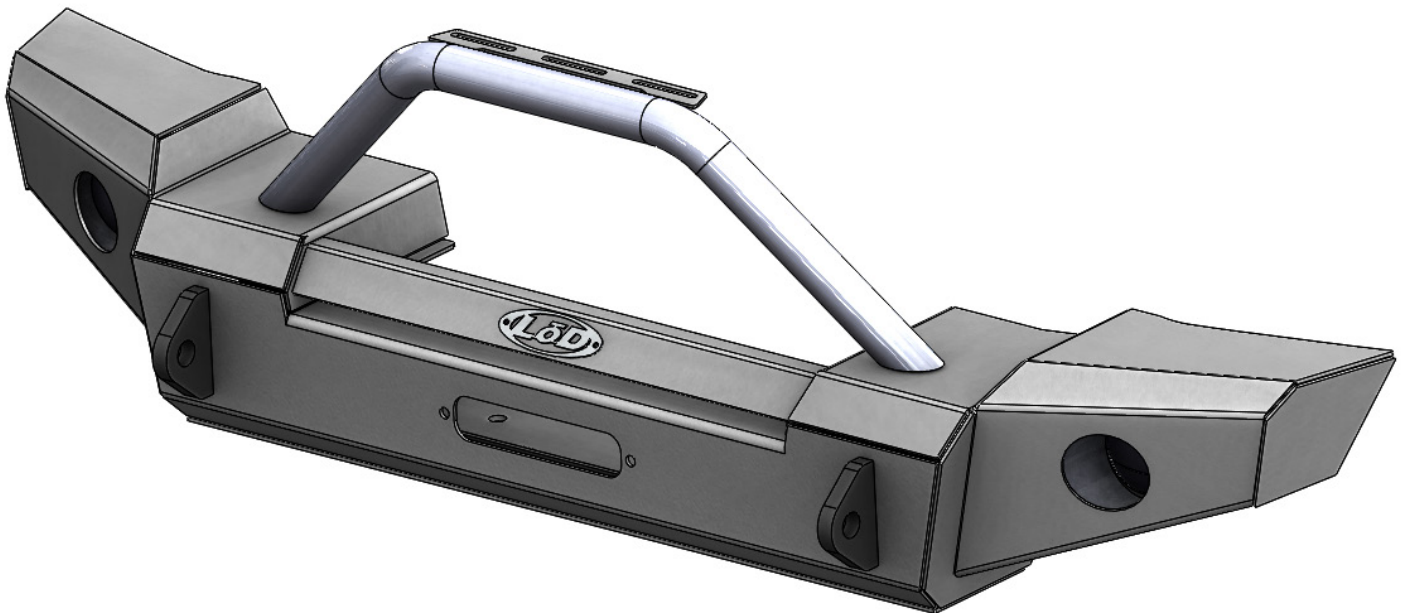

- ① The instructions shown below include removal of the original plastic from bumper. Your bumper may be different.



- ② Start by locating the 2 vertical clips and 4 horizontal clips on the top of the bumper.

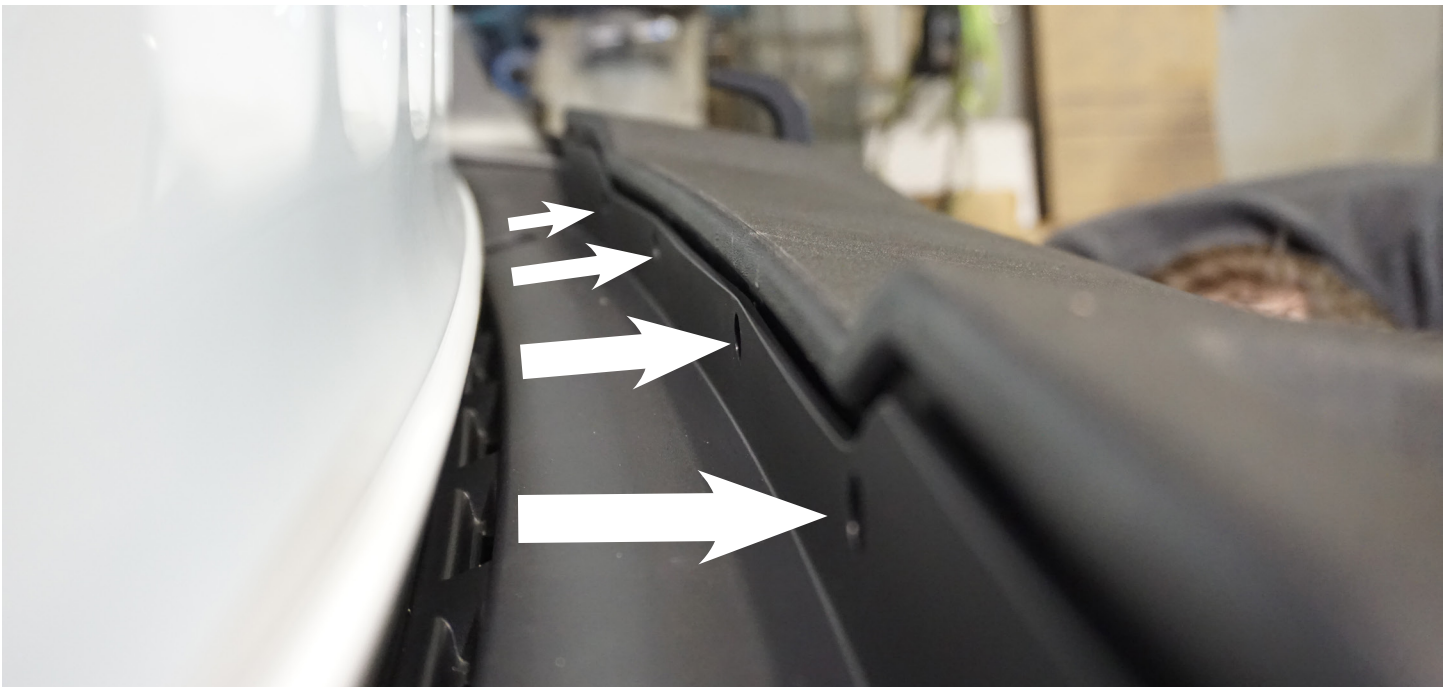

- ③ Remove (2 vertical clips, 4 horizontal) that secure the trim strip in place.

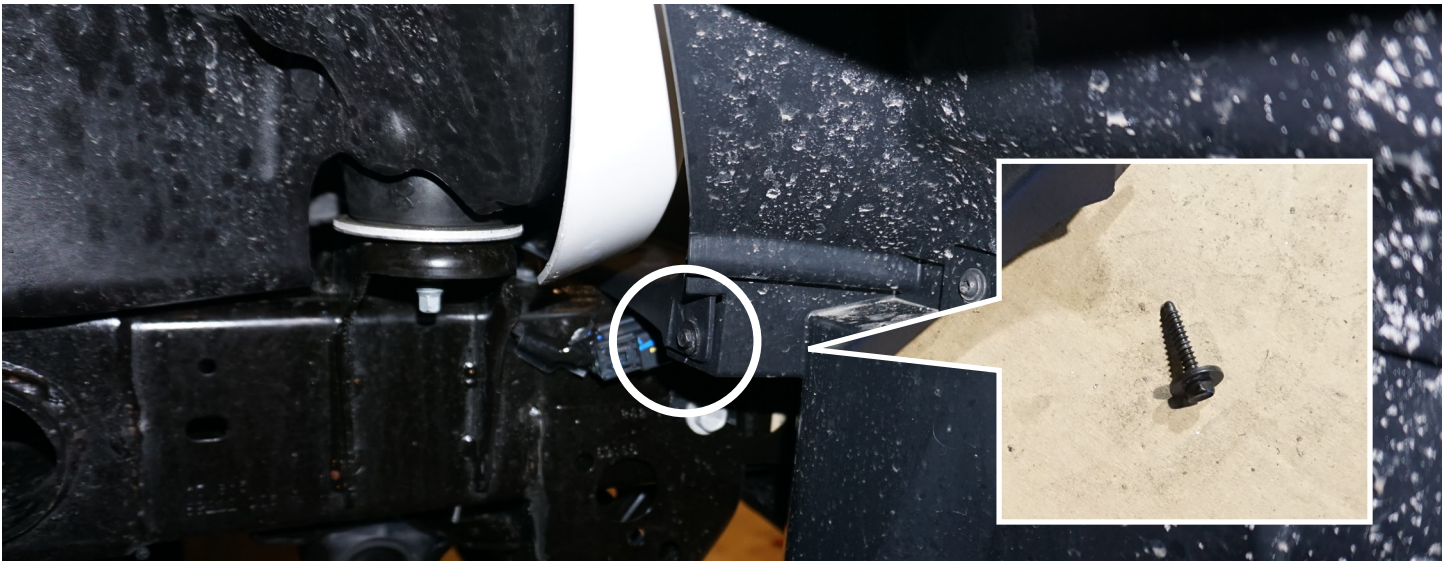

- ④ There will be 2 screws holding the trim strip to the vehicle body, one on each side. These can be accessed by reaching through the wheel well.



- ⑤ You can now remove the trim strip to access the bumper mount bolts.



- ⑥ Also remove the factory skid plate. Start with the two 6mm screws on the bottom (one on either side).



- 7** The skidplate is held to the vehicle with eight (8) clips in the front, and the two bolts you just removed, on the bottom.



- 8** Also remove the crash bar, there are two bolts holding it on. After the bolts are removed, you will shift the crash bar slightly up, then pull towards you to remove the tabs out of the opening.

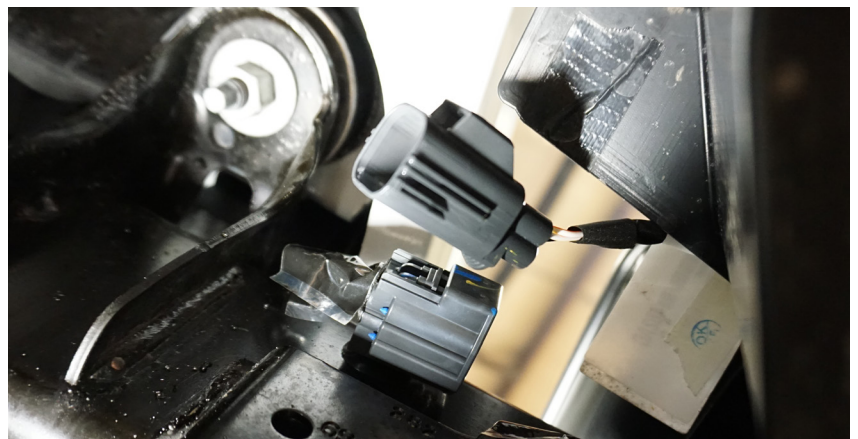
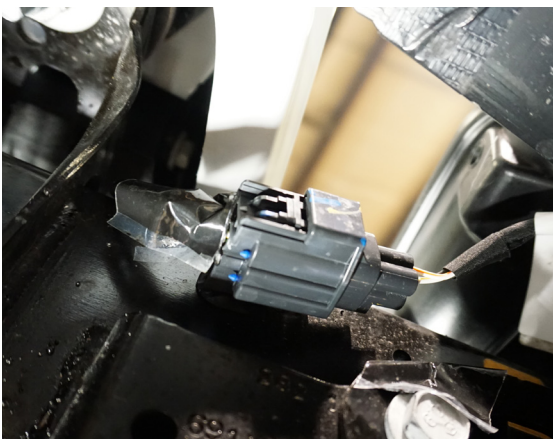

- 9** Undo the wire harness plug that connects the foglights to the vehicle.



10 The bumper is secured to the vehicle with four (4) bolts on both sides. Remove these and the bumper should come off the vehicle.

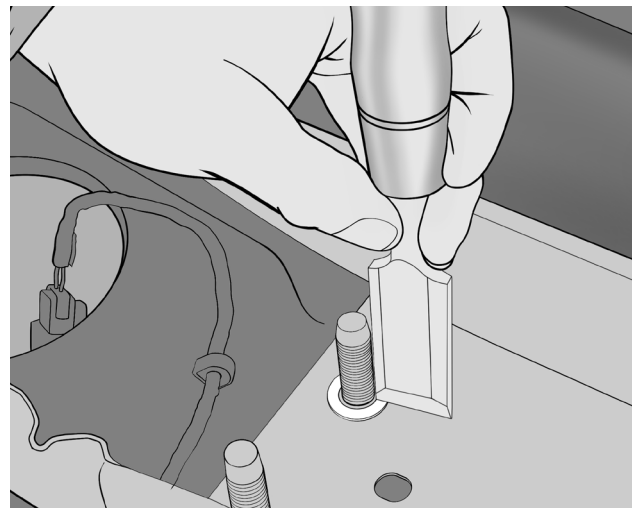
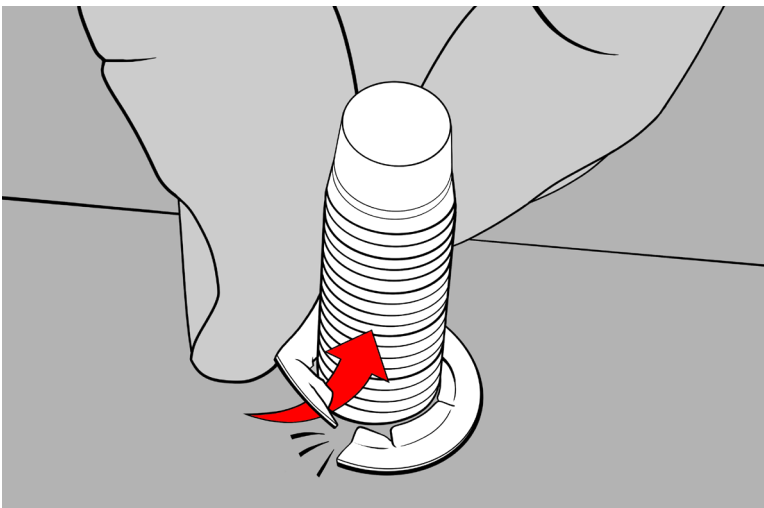

11 The bolts that hold the bumper together are held in place using locking tooth washers, you can either pry them up with a screwdriver, or cut them off using a sharp chisel or similar tool.

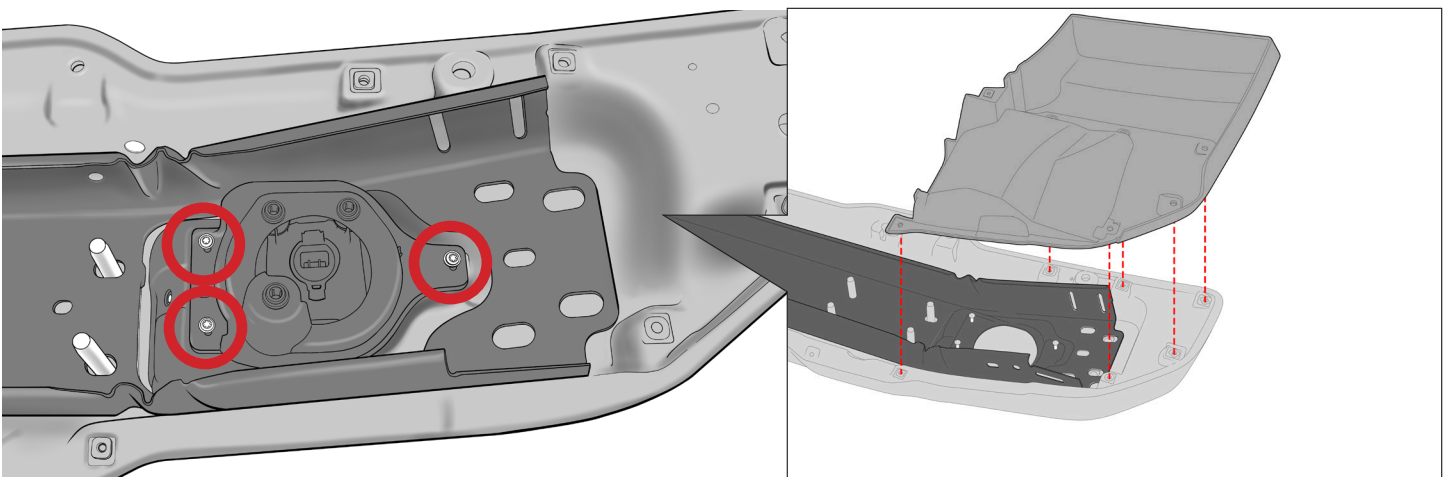

12 Once the plastic trim piece is off, remove the three T-20 screws (circled) that hold the foglight housing in place.

Jeep Foglight Configurations and Compatibility Information

Jeep Sport and Sahara Plastic OEM Bumpers

The 3 types of lights shown below are found in the OEM plastic bumpers for the Jeep Wrangler and Gladiator Sport and Sahara. Hardware is included for these with the LOD bumper. Use what you need and simply discard the extra pieces.

Halogen Fog Light

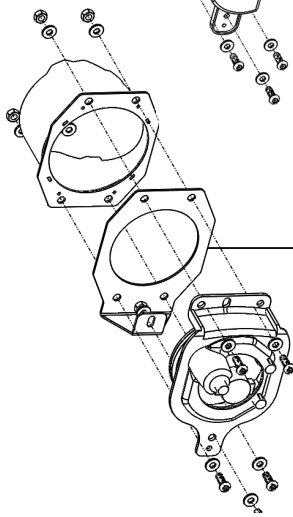

Fog Light Bracket

LED Fog Light

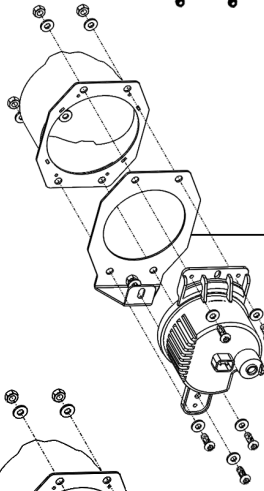

Fog Light Bracket

LED Fog Light

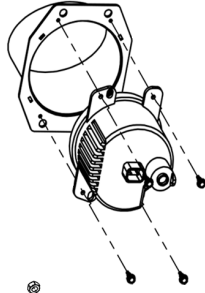

JLB1811 Assembly

If you have a 3 piece metal bumper you will need to purchase part number **JLB1811** and trim the stock light bracket to fit in the LOD bumper.

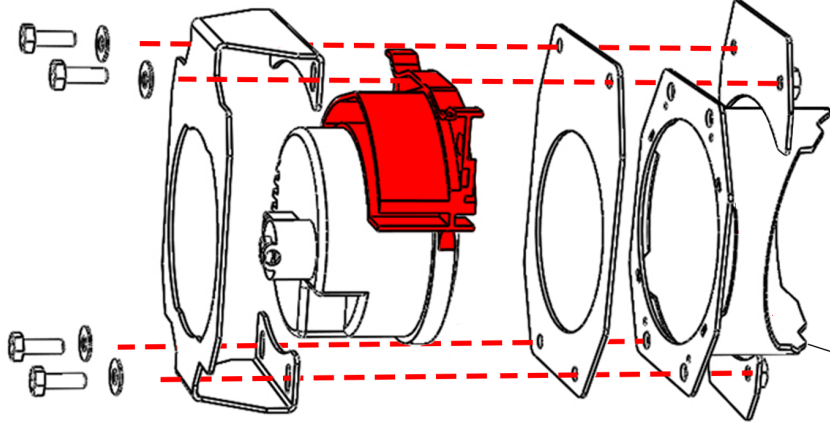

Mount located inside of bumper

Rubicon Metal OEM Bumpers

If you have a metal OEM bumper, you will need to purchase our **JLB1811 LED Bracket** to be able to use the stock foglights due to the shape of Jeep's LED design.

Once trimmed as shown below, the OEM mount should look like the one pictured below and will fit into the LOD bumper, as shown to the right. You can use the LOD housing as a template to mark where you need to cut.

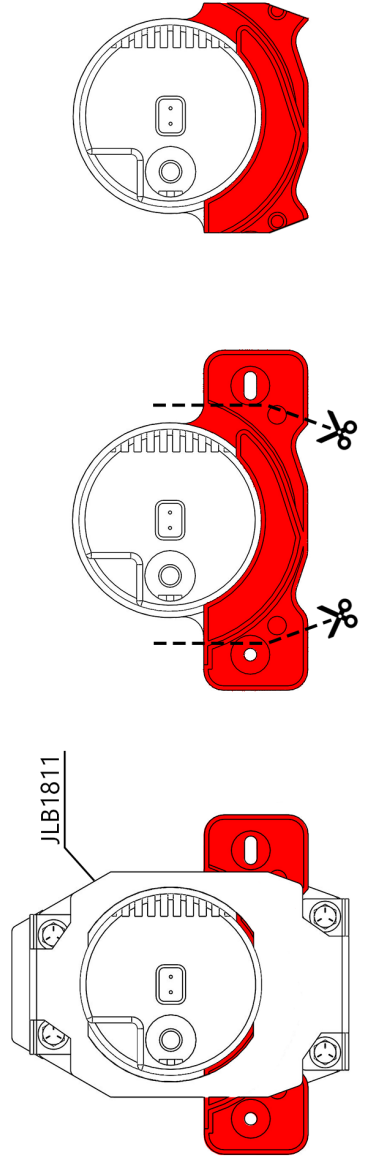

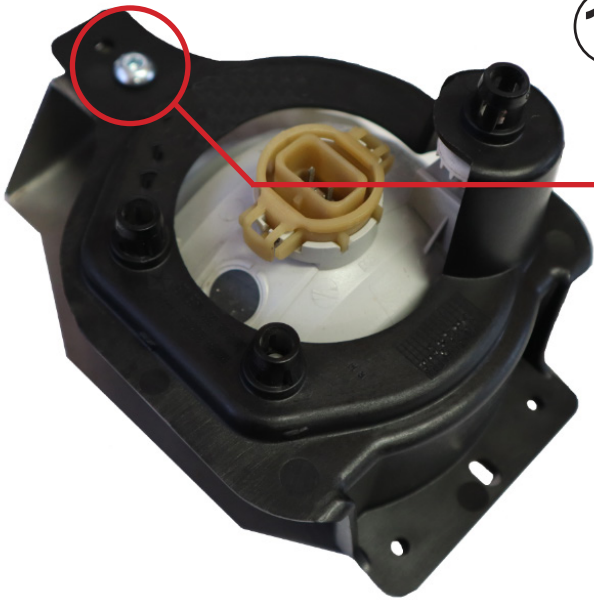

13

If your Halogen or LED fog lights are from the OEM Plastic bumper, you will need to drill a couple holes in the fog light flange to be able to mount into you LOD bumper.

Assemble your fog light to the Fog Light Bracket using the single Button Head Screw and Washer and Nut.

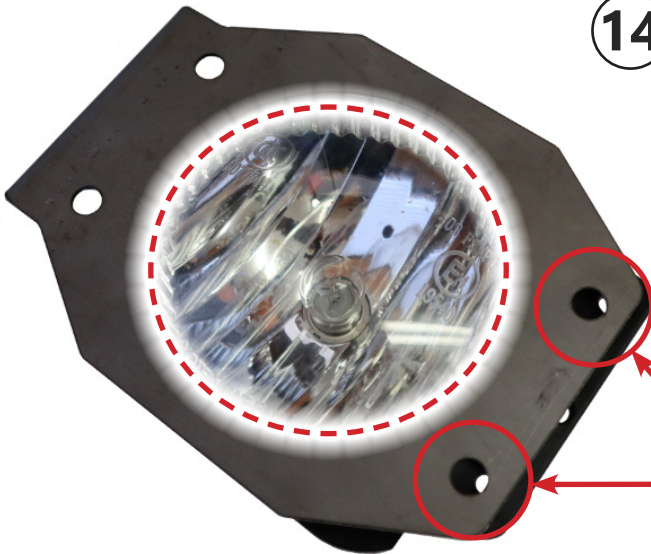

14

Center your fog light in the new Fog Light Bracket as shown and then mark the two mounting holes circled on the fog light flange. Drill these using a Ø1/4" drill bit.

Be careful when you drill these since the existing mounting holes in the plastic flange are not quite in the correct location.

Drill these two holes

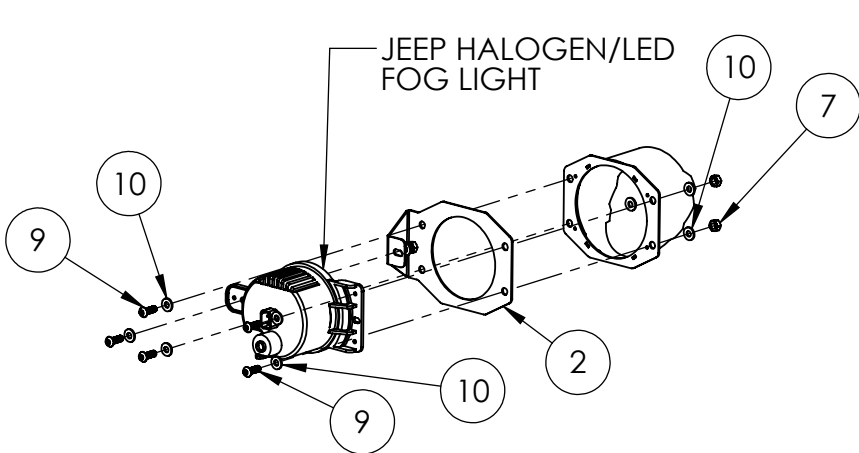

15

Once the holes are drilled, you can assemble the fog light and bracket onto the mounting bezel inside your LOD front bumper. Use the provided button head Screws, nuts and washers as shown.

- 16** Mount the Winch Plate as shown below. Depending on the brand or style of winch, you may need to move the spacers to the outer position. This will shift your winch closer to the Jeep grill.

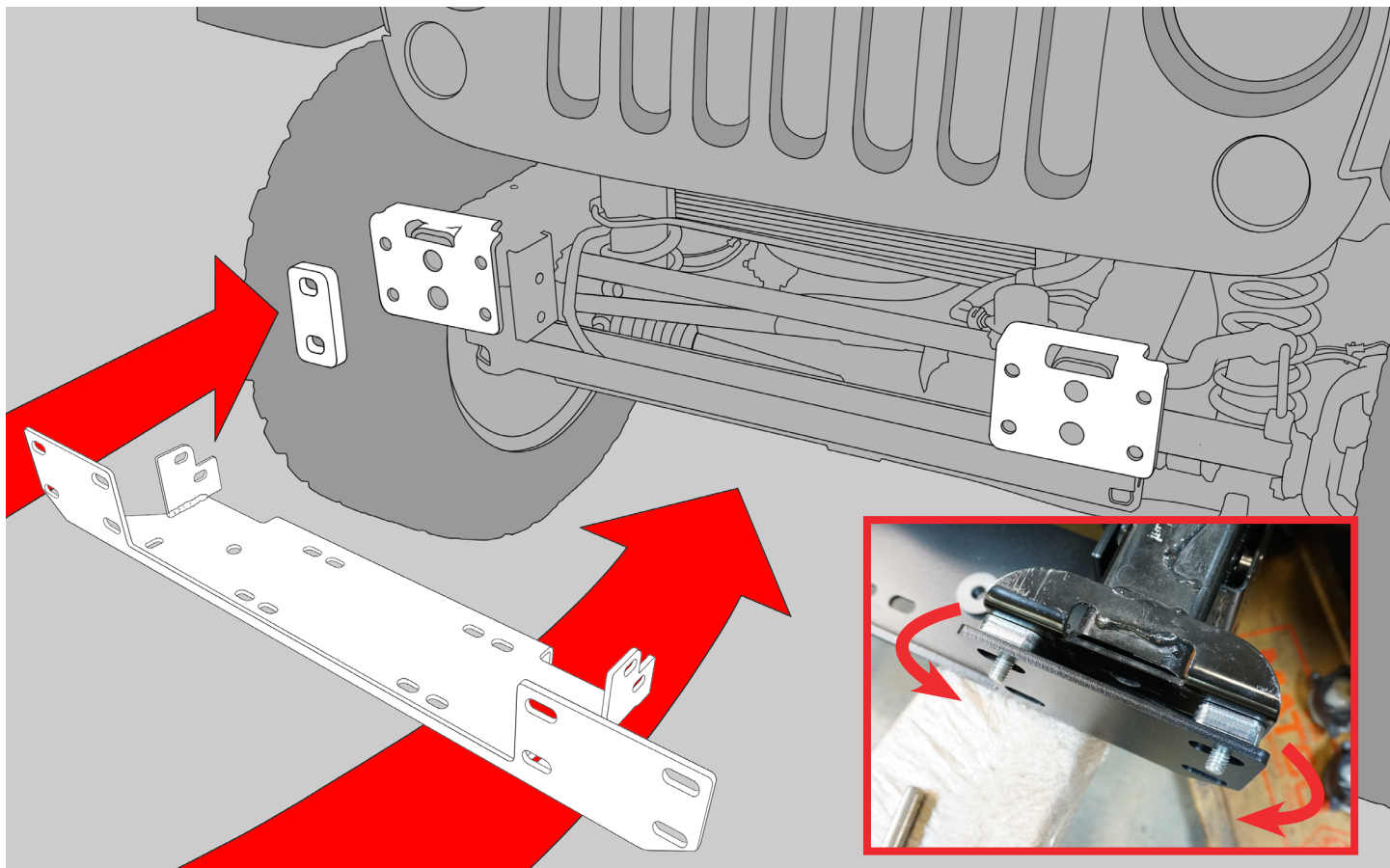

Depending on the brand or style of winch, you may need to move the spacers to the outer position. This will shift your winch closer to the Jeep grill.



Slide 2 of the steel spacers in between the winch plate and frame rail mount on your JL, then insert the long bolts and washers provided through the mounting holes and spacers as shown in this picture.

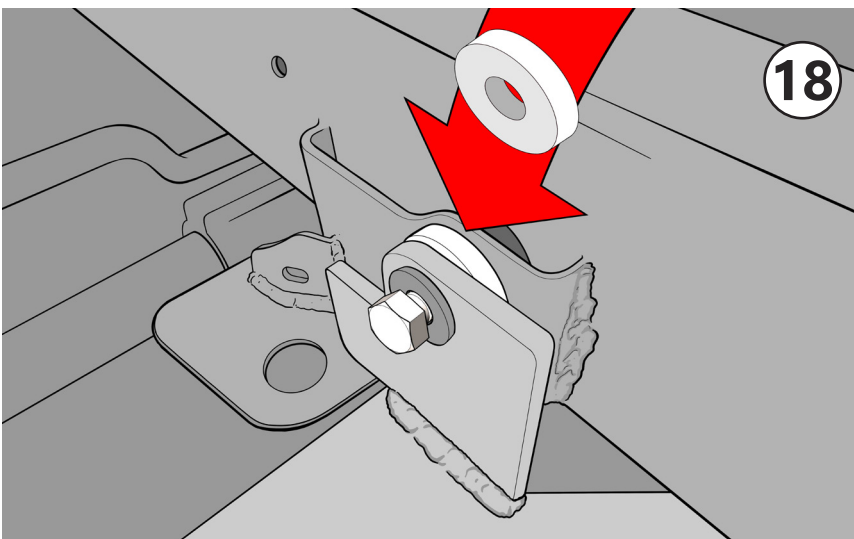

Secure the winch plate in place using the supplied washer and bolt to attach the frame rail flaps to the frame.



Using a 3/4" socket, tighten up the winch plate frame rail flaps as shown in this picture.



Repeat until all the steel spacers (8) are installed in between the winch plate and the frame rail

The bolts are should be sticking through the winch plate as shown in the picture.

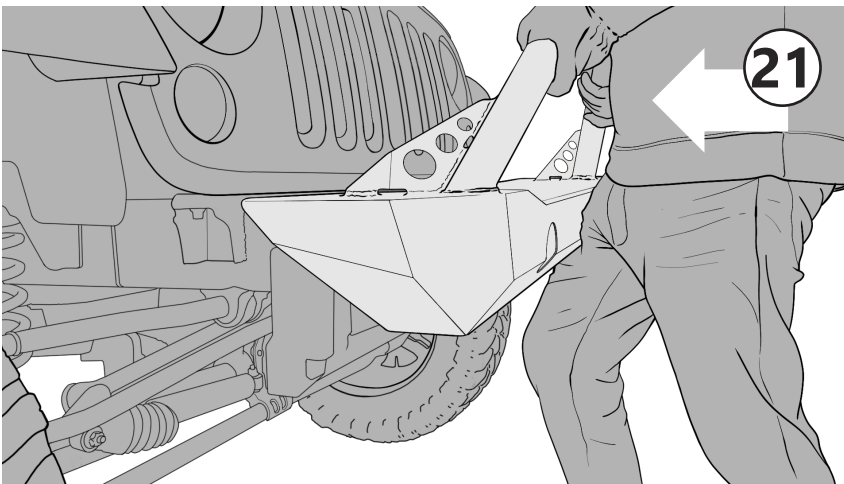

Gently slide the bumper over the frame mounts and slowly move it forward, letting it rest on top of the frame.



Loosely secure the bumper in place using the nuts provided.

Before installing all of the mounting hardware, check to make sure your winch will fit by lining it up with the mounting holes on your winch plate.



Using a 3/4" socket and wrench, install and tighten the remaining mounting bolts and nuts on the inside of your Jeep JL frame rails as shown in this picture.



Install and tighten the remaining mounting bolts and nuts located on the outside of your Jeep JL frame rails using a 3/4" socket and wrench.

ITEM NO.	PART NUMBER	DESCRIPTION	STANDARD NO BULL BAR/QTY.
1	4JFB0750-01	SIGNATURE FULL WIDTH FRONT BUMPER WELDMENT - STANDARD	1
2	4JWP0700-01	WINCH PLATE WELDMENT	1
3	2JWP0700-03	WINCHPLATE MOUNT SPACER	8
4	2JWP1800-01	SPACER WASHER	2
5	2JLB1800-03	JEEP JL/JT 2020+ FOG LIGHT BRACKET	2
6	LOGO1001	DESTROYER LOGO - EMBOSSED	1

HARDWARE KIT

ITEM NO.	PART NUMBER	DESCRIPTION	STANDARD NO BULL BAR/QTY.
7	HB431432ZPGR5	HEX BOLT 7/16-14 X 2.00 HEX BOLT ZINC PLATE GR5	8
8	HB10150M35ZPCL88	HEX BOLT M10-L.50 X 35mm ZINC PLATE CL8.8	2
9	BHSCS252012ZP	BHSCS 1/4-20 X .75 ZINC PLATE	10
10	HH081808SDZP	HEX HEAD #8 X .50 SELF DRILLING SCREW ZINC PLATE	8
11	FW4318ZP	FLAT WASHER Ø7/16 X 1.25" ZINC PLATED	18
12	FW1209ZP	FLAT WASHER #12 X .56" ZINC PLATED	20
13	HN4314ZPGR5	HEX NUT 7/16-14 ZINC PLATE GR5	8
14	HN2520ZPGR5	HEX NUT 1/4-20 ZINC PLATED GR5	10

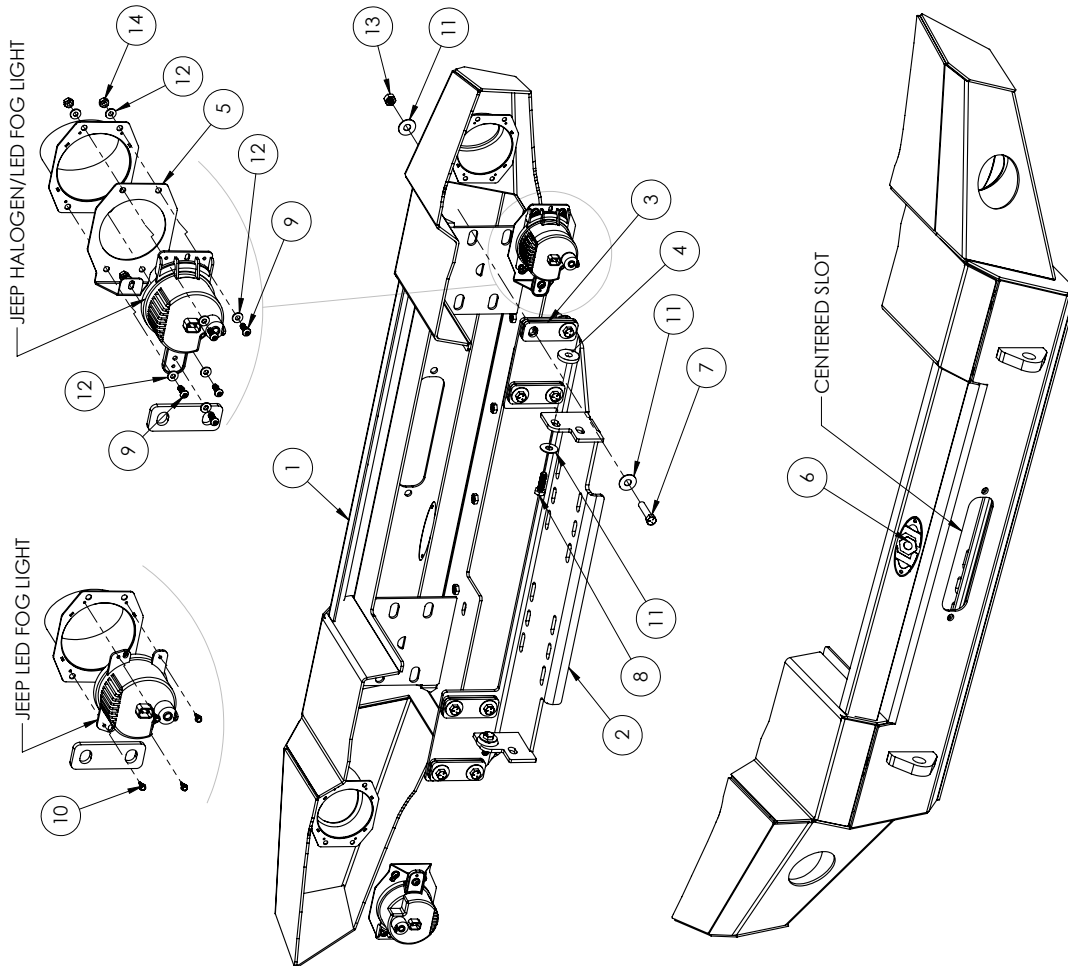

NOTES:

1. JFB1850 = BARE STEEL OPTION
2. JFB1851 = BLACK POWDER COAT OPTION

UNLESS OTHERWISE SPECIFIED: DIMENSIONS ARE IN INCHES TOLERANCES: ±0.010 ANGULAR: MACH ±1° HOLE POSITION: ±0.015 THREE PLACE DECIMAL ±0.005	NAME MCH	DATE 4/26/2021
DRAWN	CHECKED	LOD LLC.
ENG APPR.	MFG APPR.	DESCRIPTION: SIGNATURE FULL WIDTH FRONT BUMPER - STANDARD
MATERIAL: N/A	FINISH: SEE NOTE	DWG. NO. JFB1850 JFB1851
THIS DRAWING IS THE SOLE PROPERTY OF LOD LLC. REPRODUCTION IN PART OR AS A WHOLE WITHOUT THE WRITTEN PERMISSION OF LOD LLC IS PROHIBITED.	ECO: 1060	REV F
SCALE: 1:8		SHEET SIZE: B
		SHEET 1 OF 4



**JL/JT Jeep
Signature Series
FRONT BUMPER
SHIPPING SHEET**

Packaged by:

On:

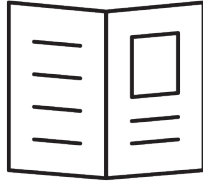

Instruction
Booklet

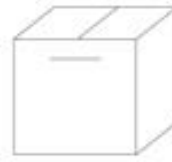

Hardware Kit

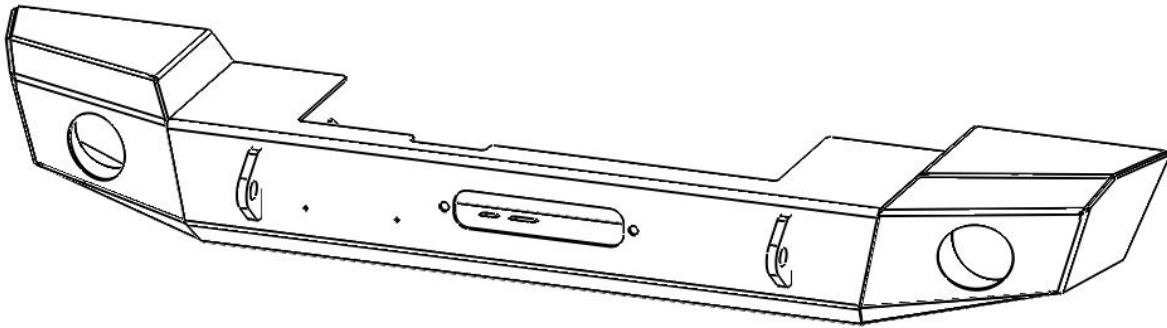

BUMPER - Style may vary

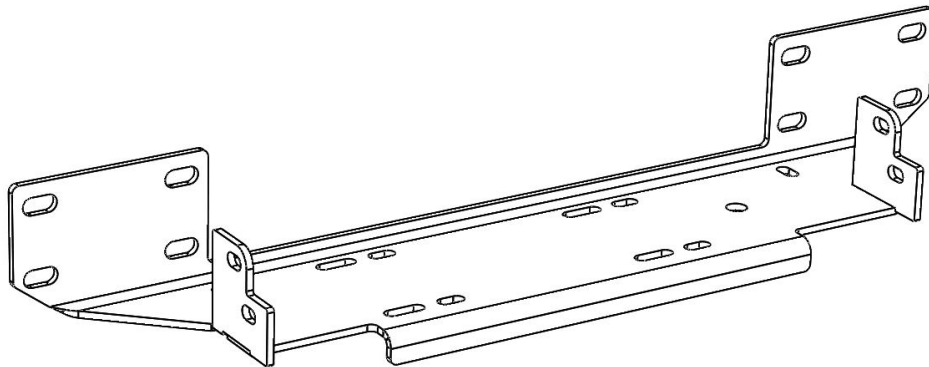

WINCH PLATE





**JL/JT Jeep
Signature Series
FRONT BUMPER
HARDWARE KIT**

Packaged by:

On:

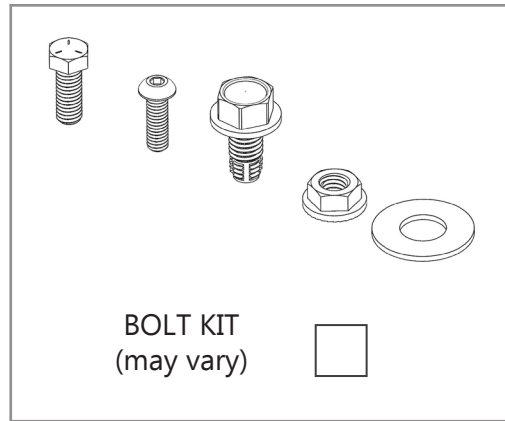

**BOLT KIT
(may vary)**

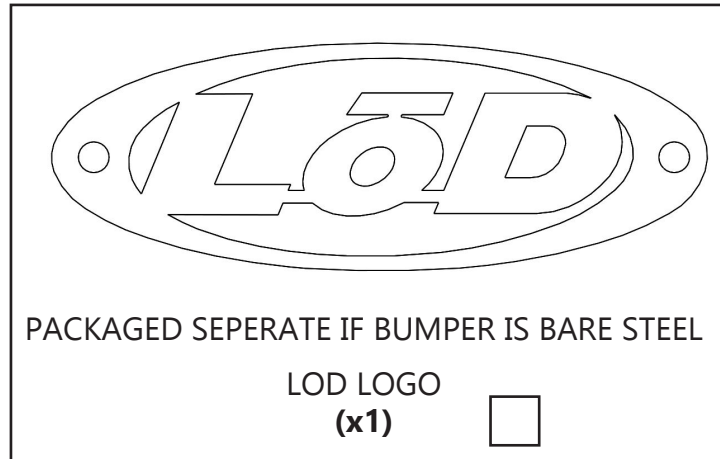

PACKAGED SEPERATE IF BUMPER IS BARE STEEL

**LOD LOGO
(x1)**

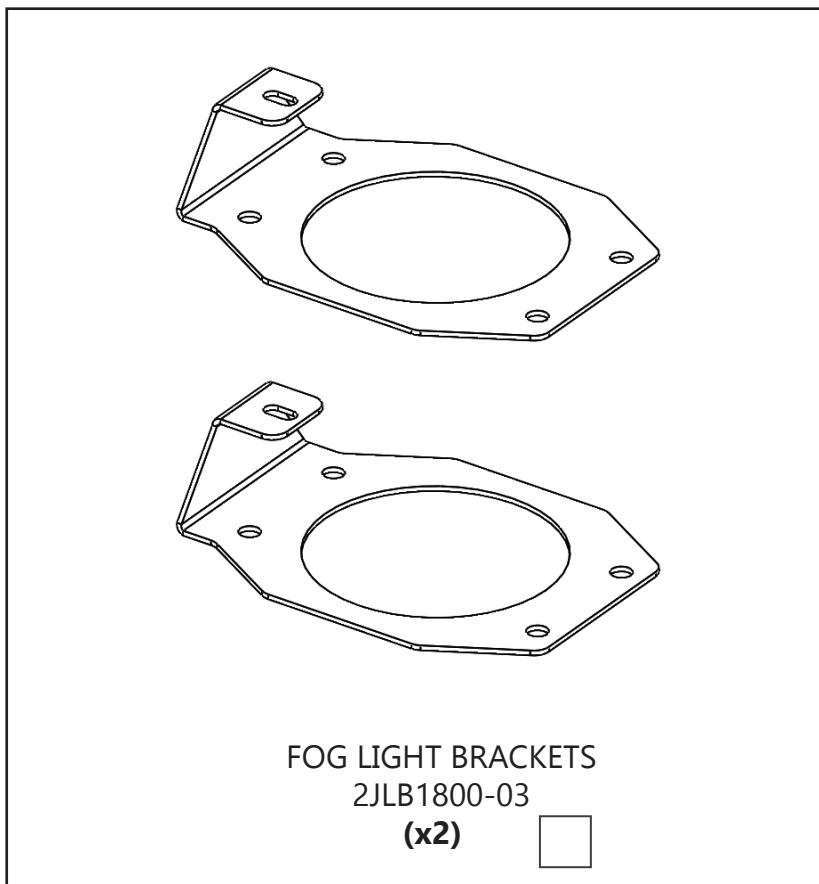

**FOG LIGHT BRACKETS
2JLB1800-03
(x2)**

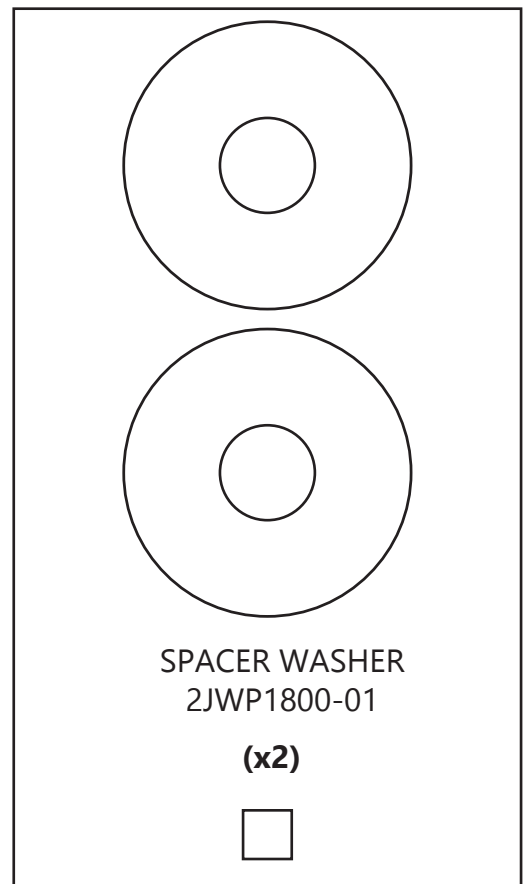

**SPACER WASHER
2JWP1800-01**

(x2)



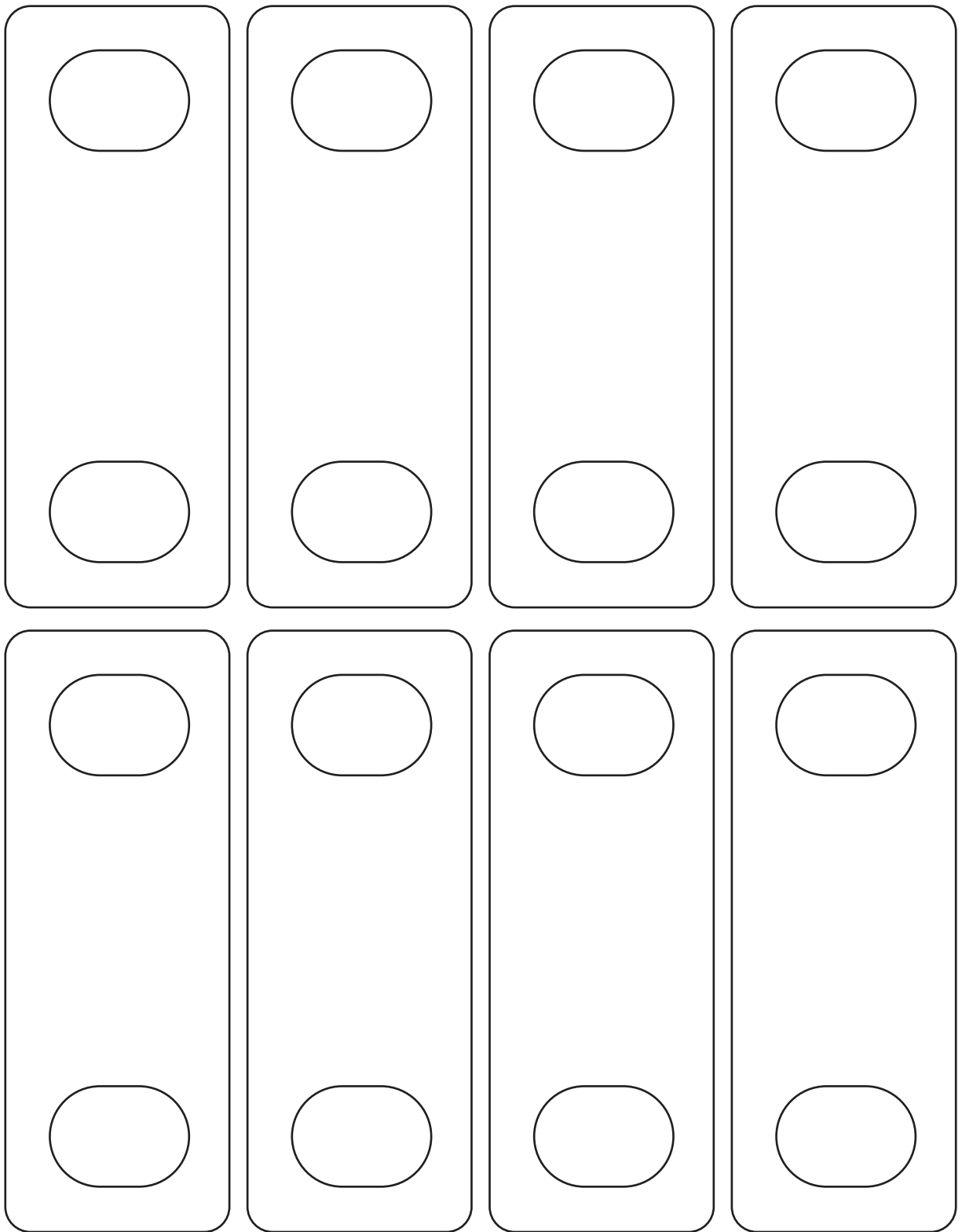

1/4" SPACER PLATES
2JWP1800-02

(x8) 



**JL/JT Jeep
Signature Series
Front Bumper
BOLT KIT**

Packaged by:

On:

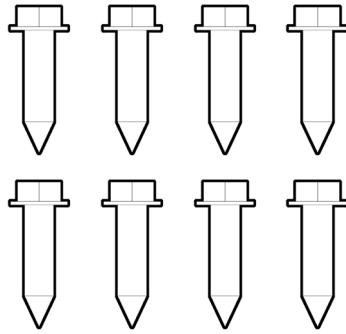

#8 SELF TAPPING SCREW

(x8)

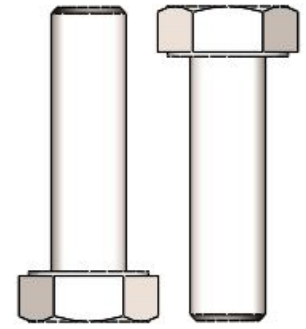

HEX BOLT
M10-1.50 X 35MM

(x2)

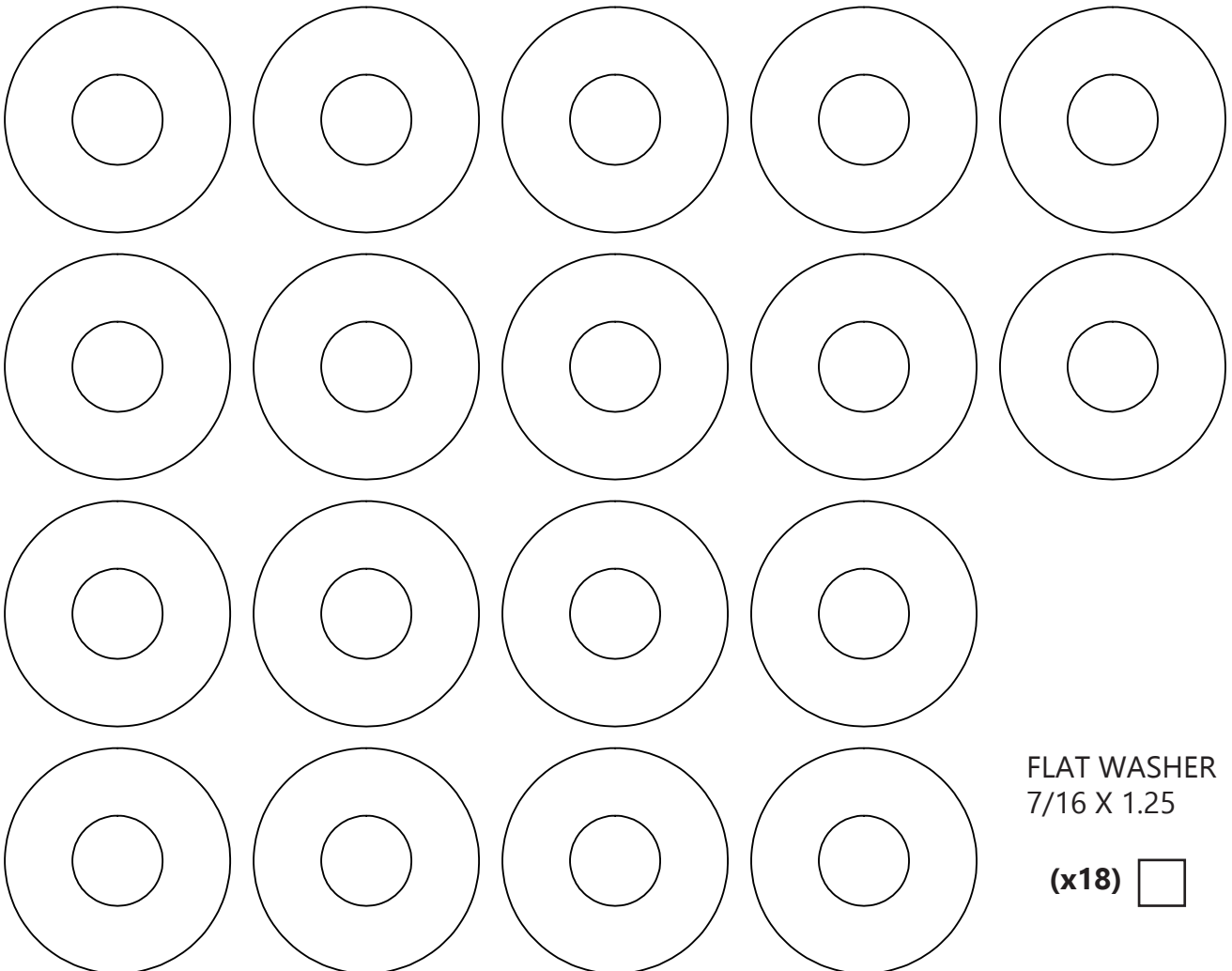

FLAT WASHER
7/16 X 1.25

(x18)



