

**Installation Steps, Floor Mats**

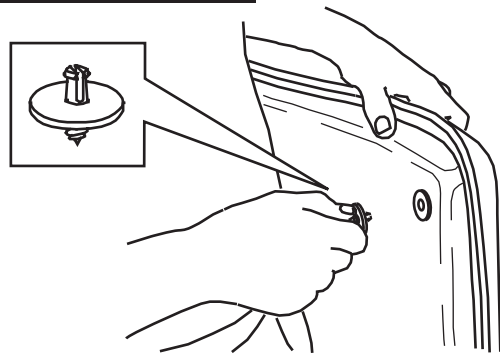

1. To install the retention system provided with your Catch-All's, first snap the anchor screws into the bottom side of the mat. Snap an anchor screw into each factory installed retention ring.

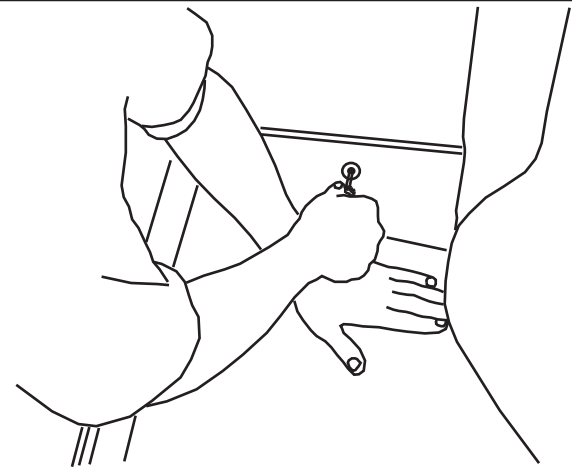

3. Hold the Catch-All firmly in place against the floor and screw the anchor screw all the way into the floor carpet.

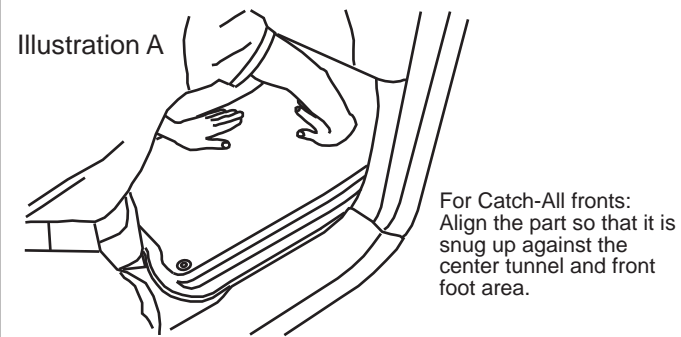
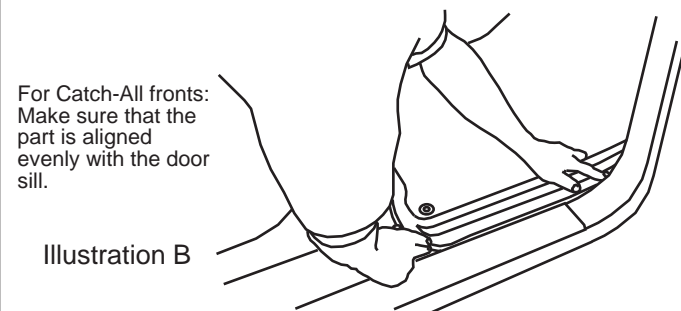

Illustration A  
For Catch-All fronts: Align the part so that it is snug up against the center tunnel and front foot area.



For Catch-All fronts: Make sure that the part is aligned evenly with the door sill.

Illustration B

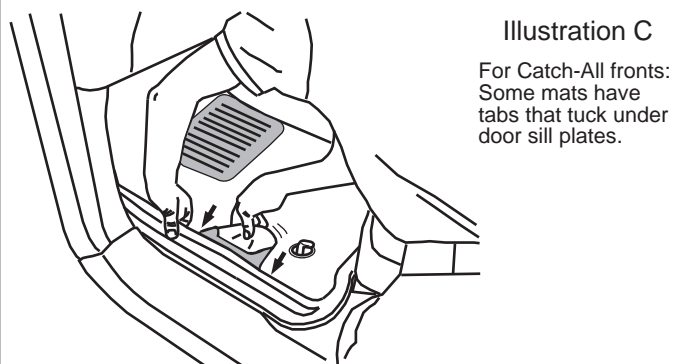

Illustration C  
For Catch-All fronts: Some mats have tabs that tuck under door sill plates.

2. Place the Catch-Alls in your vehicle and position for best fit (see illustrations "A", "B", and "C").

4. Apply the snap covers over all of the snap fasteners.

**Care and Cleaning**

To remove for cleaning, lift the Catch-All and unsnap the anchor screws one at a time from each retention ring. To re-install, simply snap back into place!

**Note:** To remove the anchor screws from the factory carpet, simply remove the Catch-Alls and unscrew them. To unscrew the anchor screws, you must clamp onto the snap stud with pliers or small vice grips and turn while lifting gently. Do not attempt to pull or tear them out, as this will cause damage. To remove any mark left by the anchor screws brush over the area with a vacuum brush attachment.



Lund International  
300 Horizon Drive  
Suwanee, GA 30024

800-328-5863 • Fax 800-782-5448 • Visit us at [lundinternational.com](http://lundinternational.com)

©2006 Lund International, Inc. All rights reserved.

Lund® and the Lund® logo are trademarks of Lund International, Inc.



**Installation Instructions**

# Nifty™

Catch-All® & Xtreme Catch-All™ Snap Fastener System  
Catch-All® & Xtreme Catch-All™ Rear Liner

For proper installation and best possible fit, please read all instructions BEFORE you begin. Some Honda and Toyota vehicles use factory clips to hold the driver's side mat into position. These are not supplied with this kit.

For technical assistance or to obtain missing parts, please call Customer Service at 1-800-356-5666

**Important Safety Information** ⚠ **WARNING**

To avoid serious personal injury or property damage:

- Be sure your floor-mats are properly installed and restrained with the snap fastener system.
- Unrestrained floor-mats can interfere with the foot controls of the vehicle.
- Be careful when entering and exiting the vehicle. The raised edge of the floor-mat can be a potential trip hazard.

**Contents**

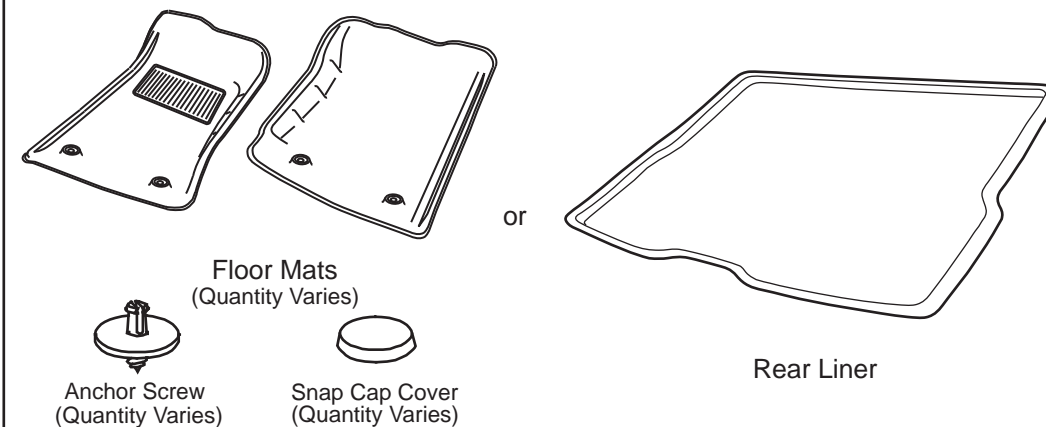

Floor Mats  
(Quantity Varies)  
Anchor Screw  
(Quantity Varies)  
Snap Cap Cover  
(Quantity Varies)

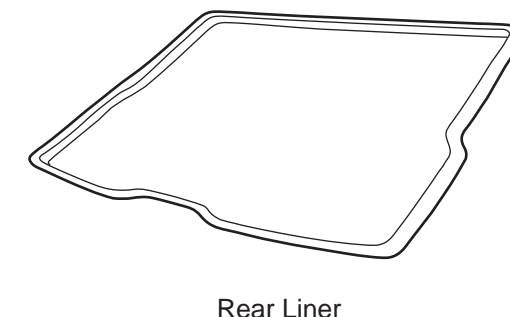

Rear Liner

**Tools Required**

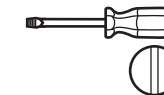

Flat Head  
Screwdriver

**Installation Steps, Rear Liners**

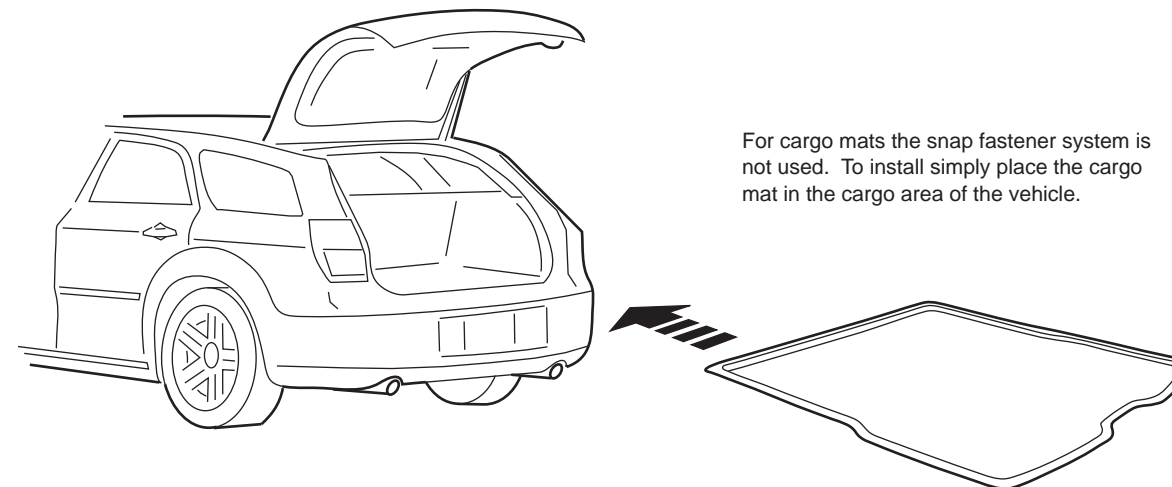

For cargo mats the snap fastener system is not used. To install simply place the cargo mat in the cargo area of the vehicle.

1.