

**MB1070 - Assembly Instructions Front Inner Fenders for JK/JKU**

**MB1070 - FRONT INNER  
FENDERS FOR JK/JKU**

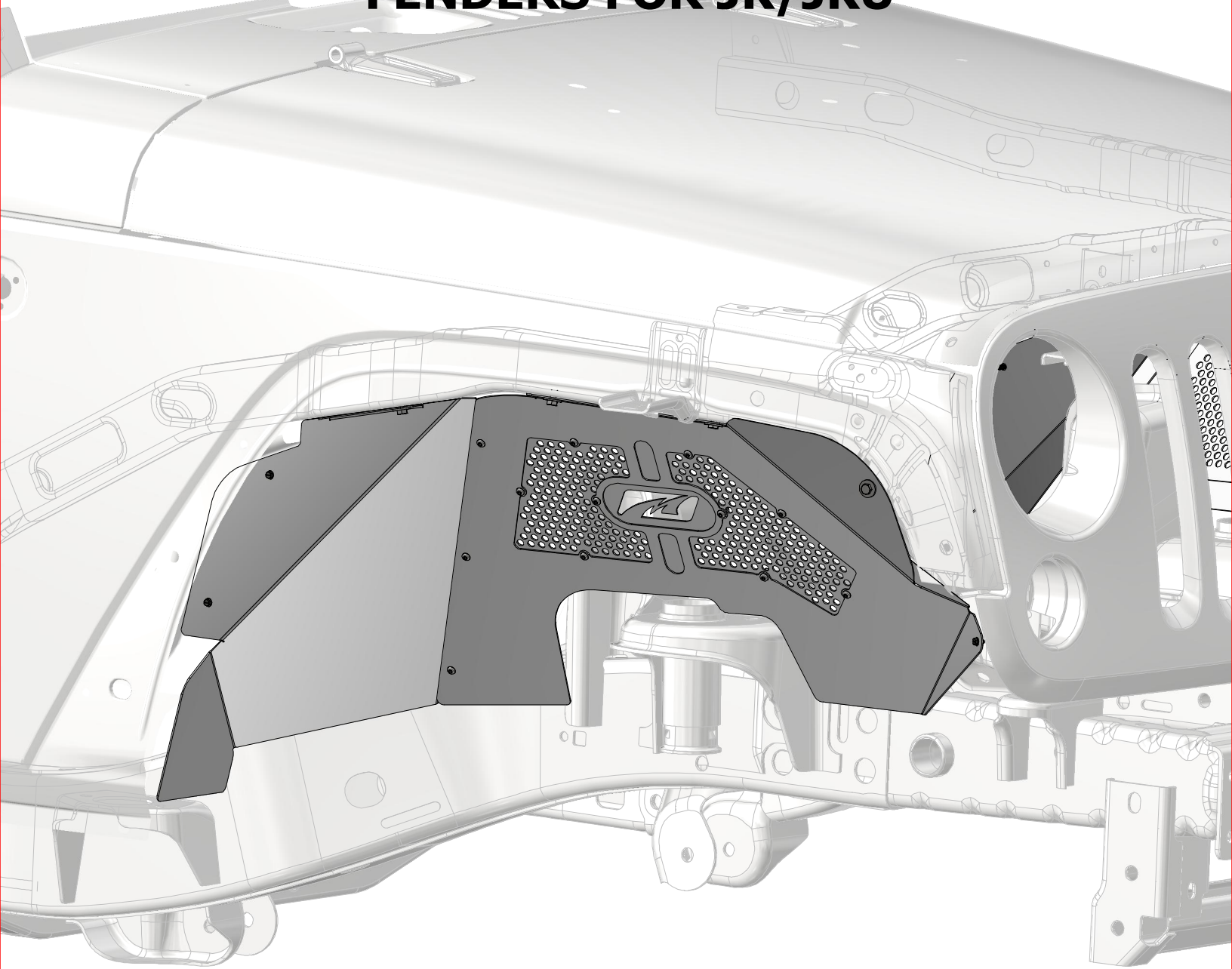

**ASSEMBLY INSTRUCTIONS**

**MB1070 - Shipping Front Inner Fenders for JK/JKU**

**CONTENTS**

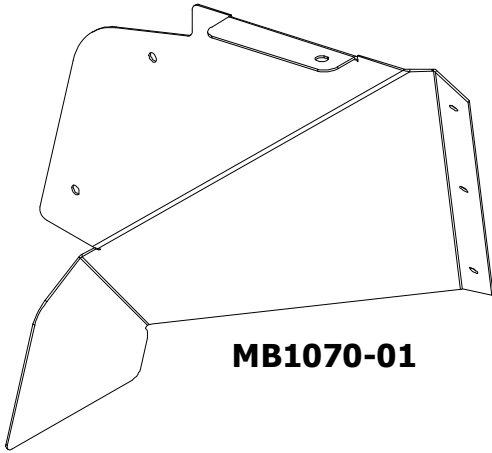

**MB1070-01**

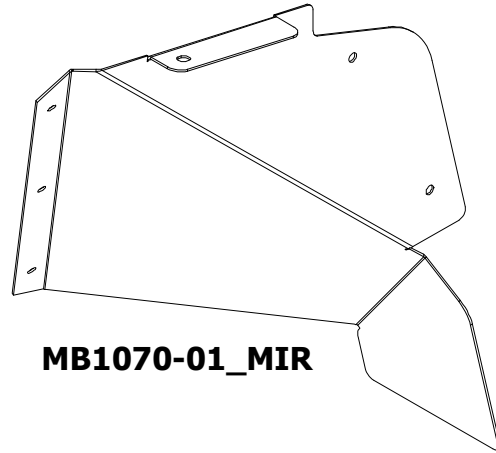

**MB1070-01\_MIR**

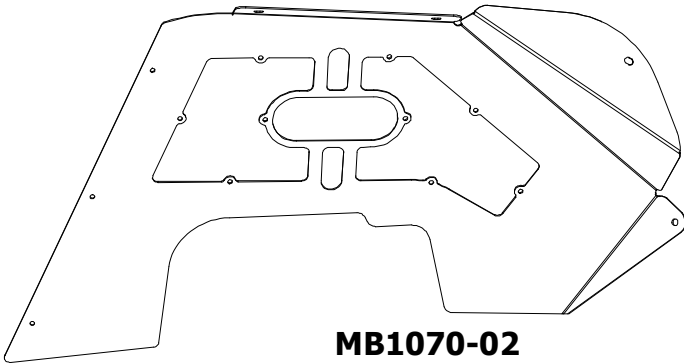

**MB1070-02**

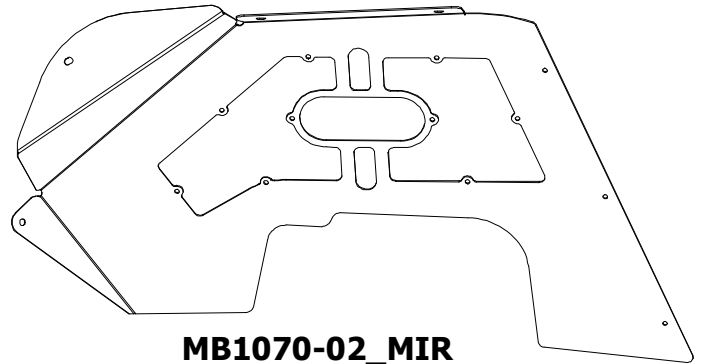

**MB1070-02\_MIR**

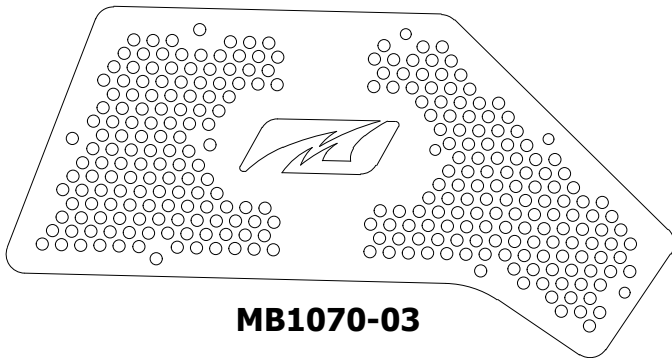

**MB1070-03**

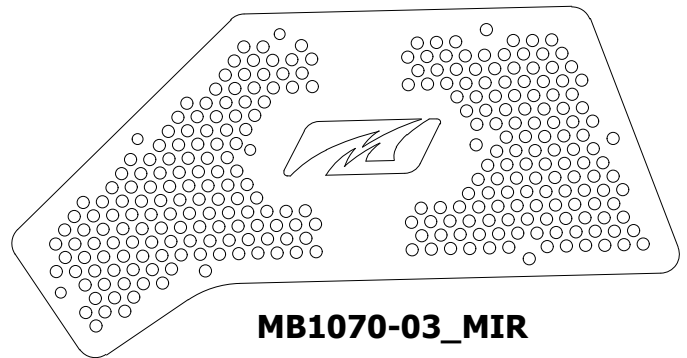

**MB1070-03\_MIR**

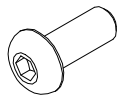

**#10-24 x 1/2"**  
**BUTTON HEAD CAP SCREW**  
Qty: 24

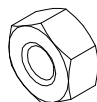

**#10-24**  
**NYLOCK HEX NUT ZINC**  
Qty: 18



**M6 FLAT WASHER STAINLESS**  
Qty: 8

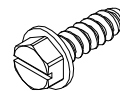

**1/2" LG #8**  
**WASHERHEAD**  
**SELF-TAPPING SCREW**  
Qty: 6

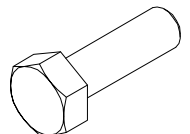

**M6 x 20mm**  
**HEX BOLT STAINLESS**  
Qty: 8

**MB1070 - Assembly Instructions Front Inner Fenders for JK/JKU**

**ASSEMBLY STEP 1**

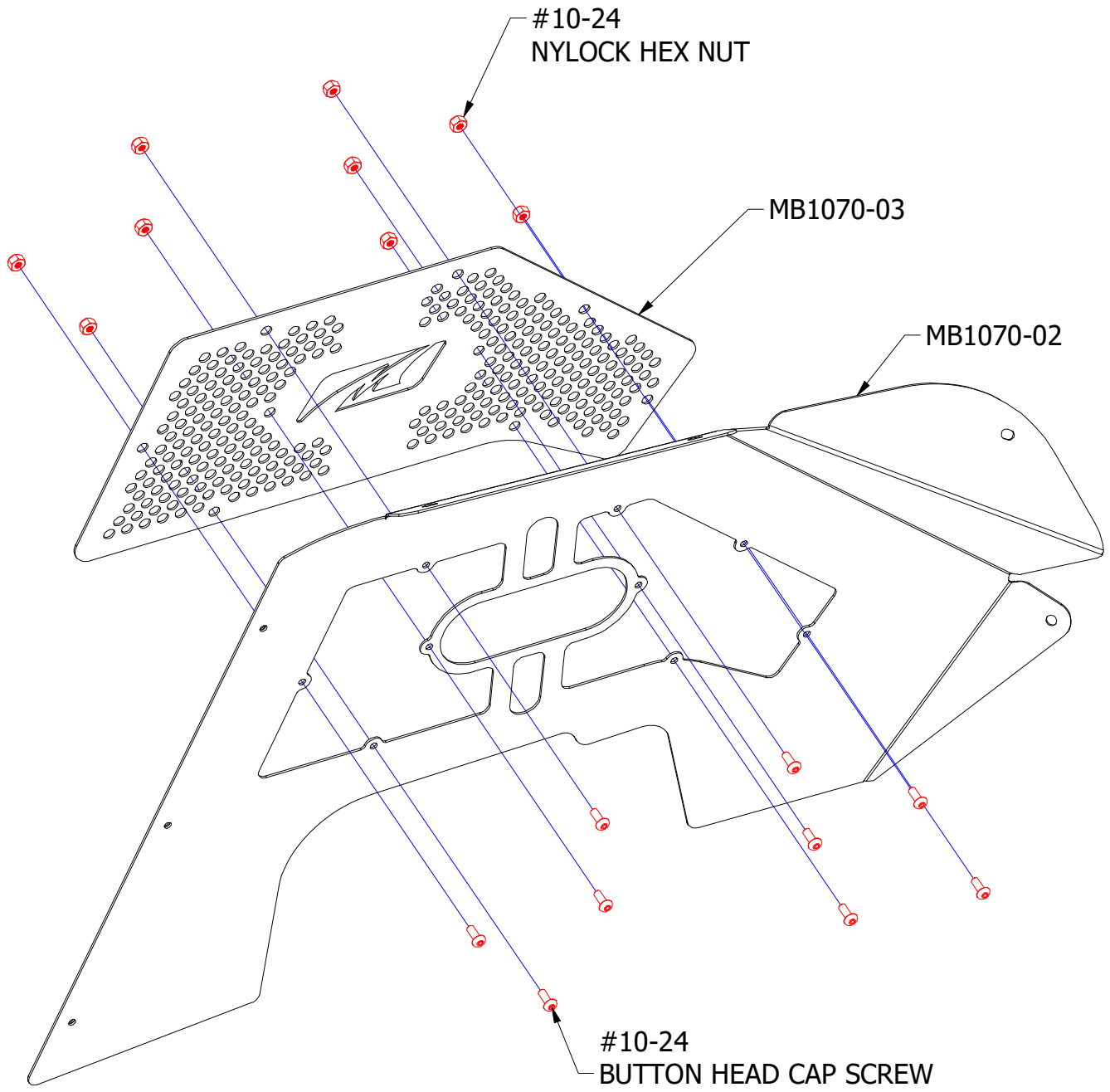

**MB1070 - Assembly Instructions Front Inner Fenders for JK/JKU**

**ASSEMBLY STEP 2**

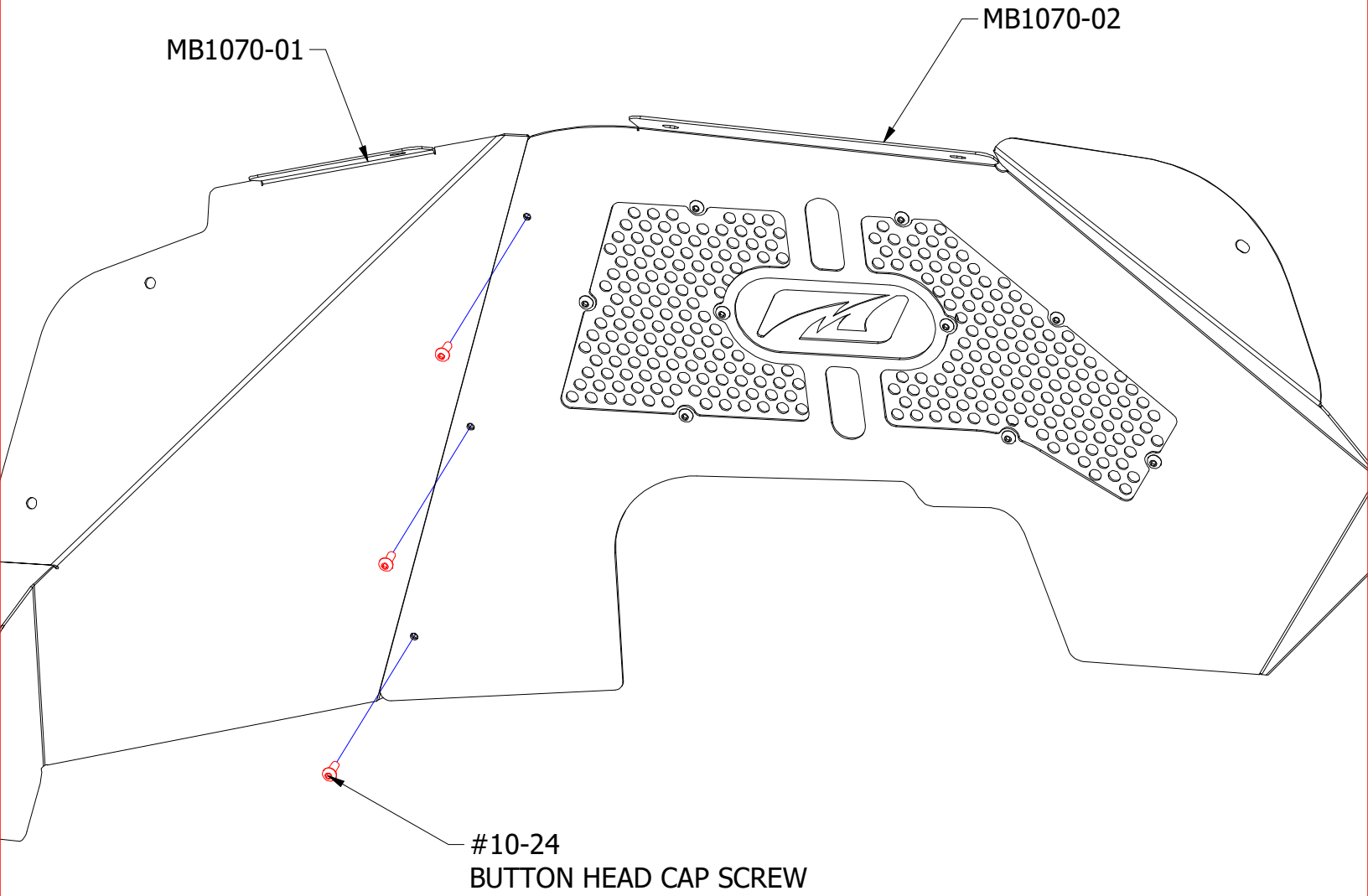

**MB1070 - Assembly Instructions Front Inner Fenders for JK/JKU**

**ASSEMBLY STEP 3**

