

MB1149 - Assembly Instructions

Tomahawk Frame Chop Front Bumper

Compatible with JK / JKU / JL / JLU / JT



ASSEMBLY INSTRUCTIONS

MB1149

CONTENTS

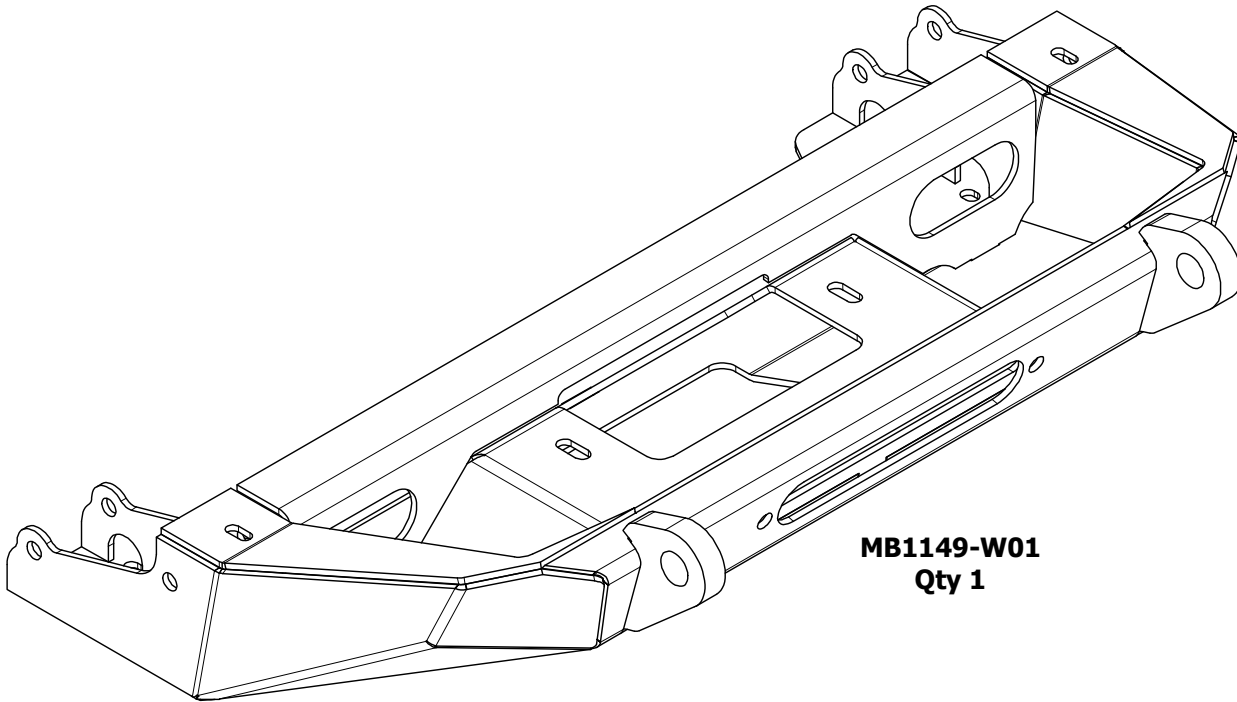

MB1149-W01
Qty 1

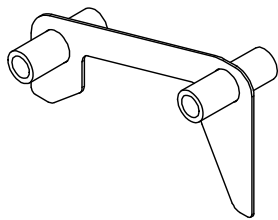

MB1149-W02
Qty 1

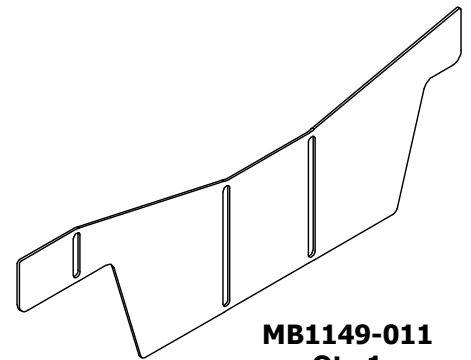

MB1149-011
Qty 1

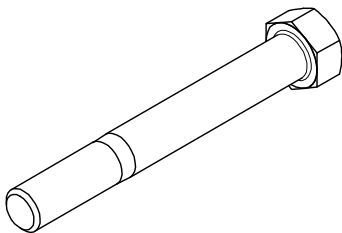

1/2-13 x 4" Hex G8 YZ
Qty 4

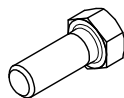

3/8-16 x 1" Hex G8 YZ
Qty 2



3/8" Flat Washer G8 YZ
Qty 2



3/8"-16 U-Nut
Qty 2



1/2" Flat Washer G8 YZ
Qty 8

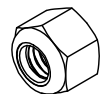

1/2"-13 Nylock Nut G8 YZ
Qty 4

MB1149-BB

CONTENTS

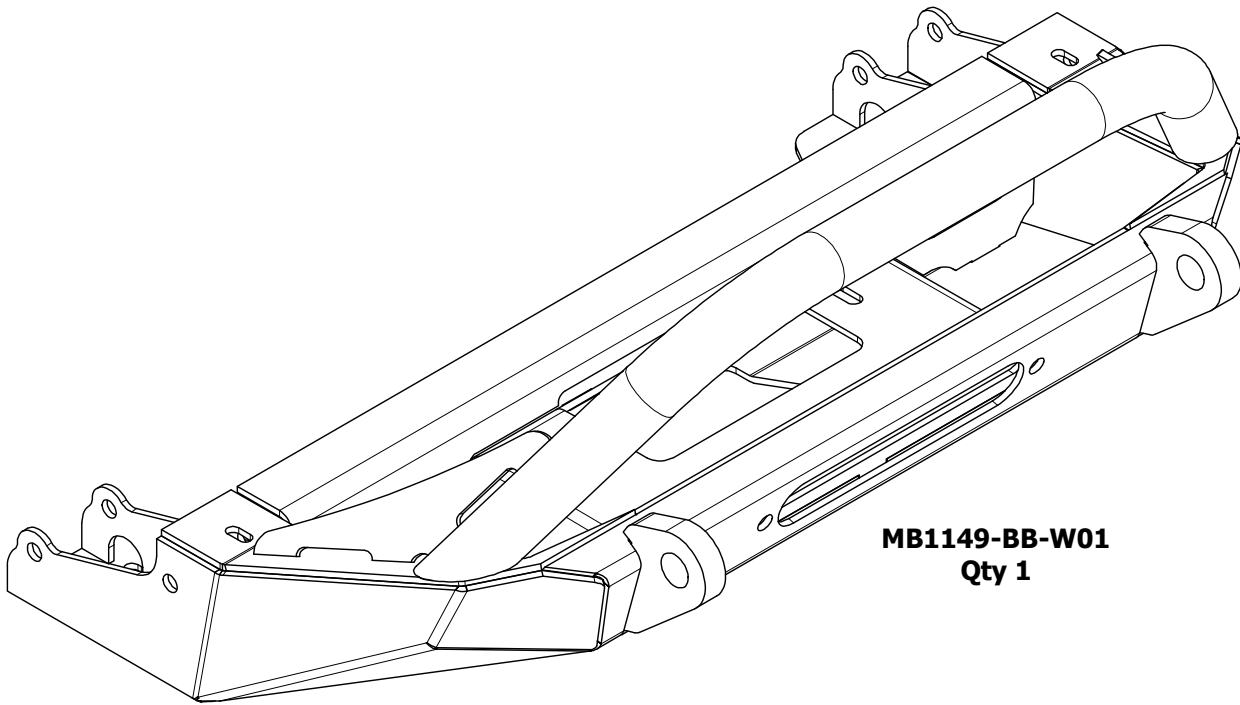

MB1149-BB-W01
Qty 1

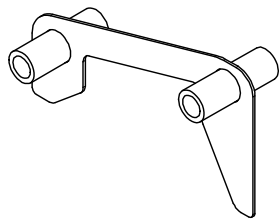

MB1149-W02
Qty 1

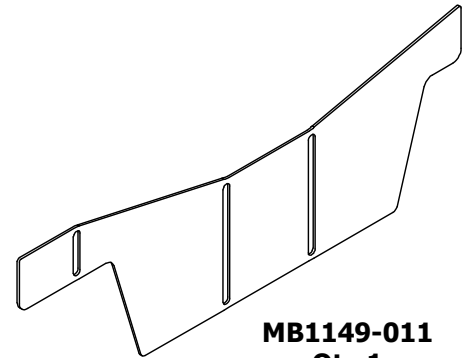

MB1149-011
Qty 1

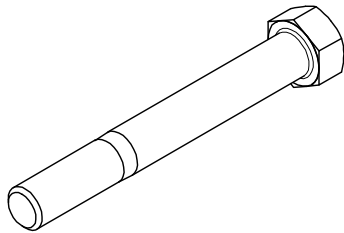

1/2-13 x 4" Hex G8 YZ
Qty 4

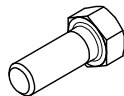

3/8-16 x 1" Hex G8 YZ
Qty 2



3/8" Flat Washer G8 YZ
Qty 2



3/8"-16 U-Nut
Qty 2



1/2" Flat Washer G8 YZ
Qty 8

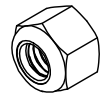

1/2"-13 Nylock Nut G8 YZ
Qty 4



Preparation and Installation Guide

Compatibility: This product fits Jeep JK / JKU / JL / JLU / JT from 07-Present. This bumper is designed to be a replacement for the factory bumper and provide support for a winch. Frame modifications are required to mount this bumper. Bumper is designed to fit a standard winch mounting pattern of 10" x 4.5" and has been tested with the Warn VR EVO and Zeon series winches.

1. Prepare and Inspect: Unbox and inspect all components to ensure everything is included and free of damage.

2. Prep for Install: Begin by removing the factory bumper. Then follow instructions for removing brackets and cutting the front of the frame.

3. Finishing: All parts are shipped bare metal and will need to be painted or powder coated to prevent corrosion.

Pro Tip: Use STEEL-IT paint, which can be welded through and easily touched up afterward.

Note: Motobilt, Inc. products are intended for **OFF-ROAD USE ONLY**. See full legal disclaimer at the end of these instructions.

JK Front Frame Section

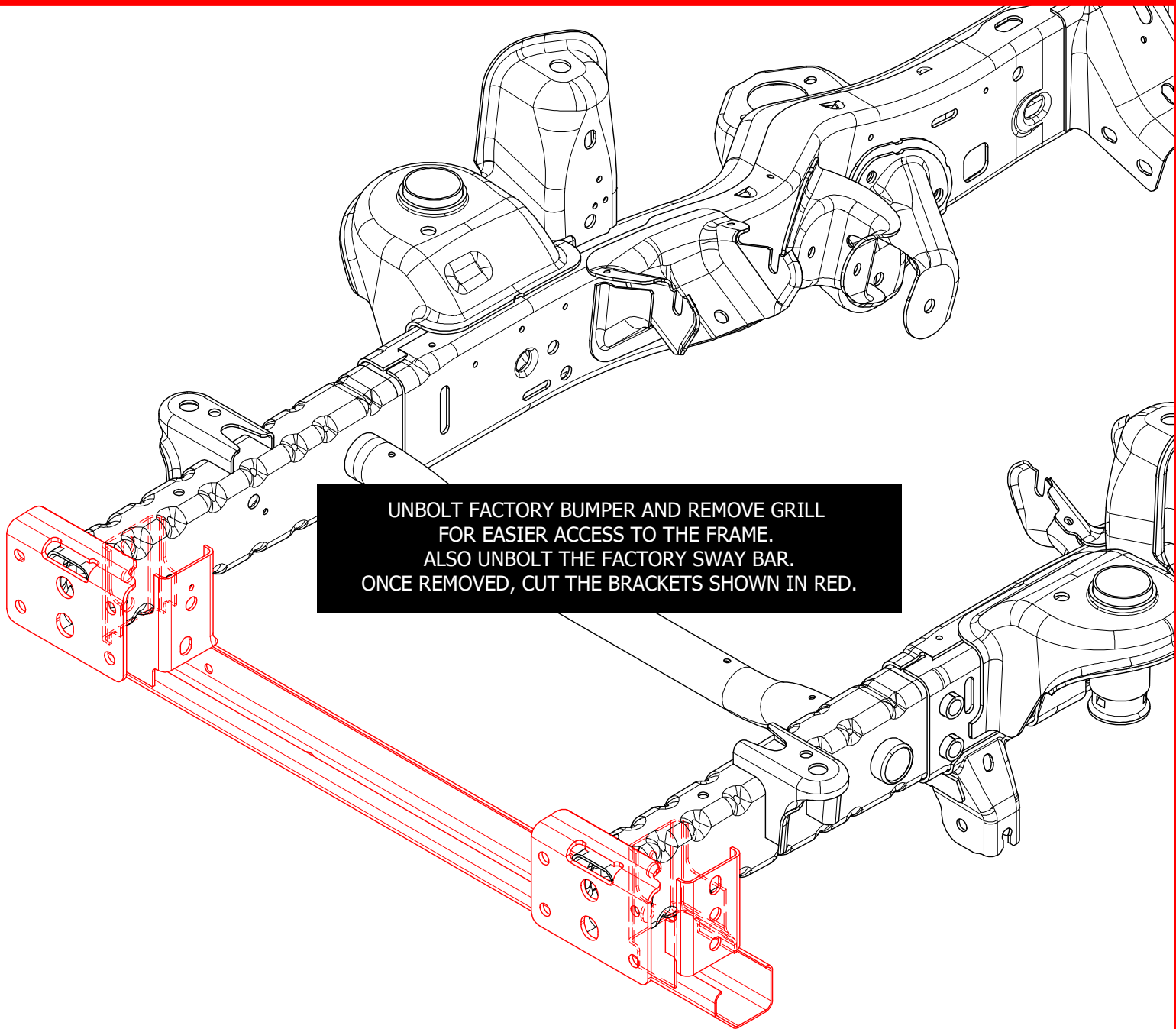

UNBOLT FACTORY BUMPER AND REMOVE GRILL FOR EASIER ACCESS TO THE FRAME.
ALSO UNBOLT THE FACTORY SWAY BAR.
ONCE REMOVED, CUT THE BRACKETS SHOWN IN RED.

NOTE: THE FACTORY RUBICON SWAY BAR WITH ELECTRONIC DISCONNECT CAN NOT BE USED WITH THIS BUMPER.

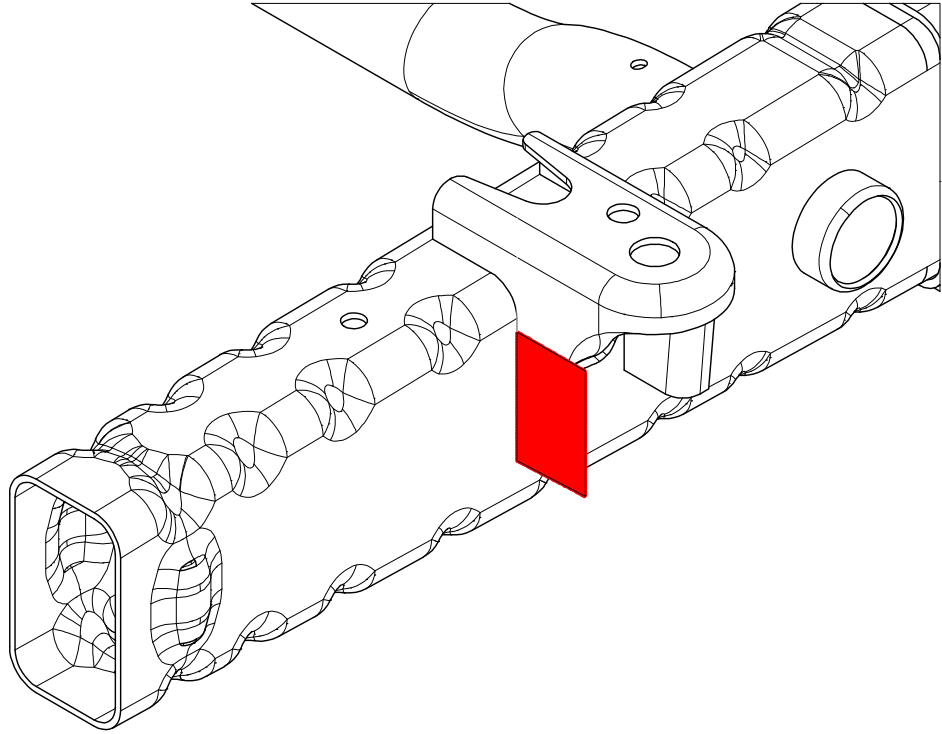
JK Front Frame Section

MEASURE AND TRIM BODY MOUNT. TRIM 1-3/4" FROM THE TOP OF THE MOUNT AND GRIND SMOOTH AS SHOWN

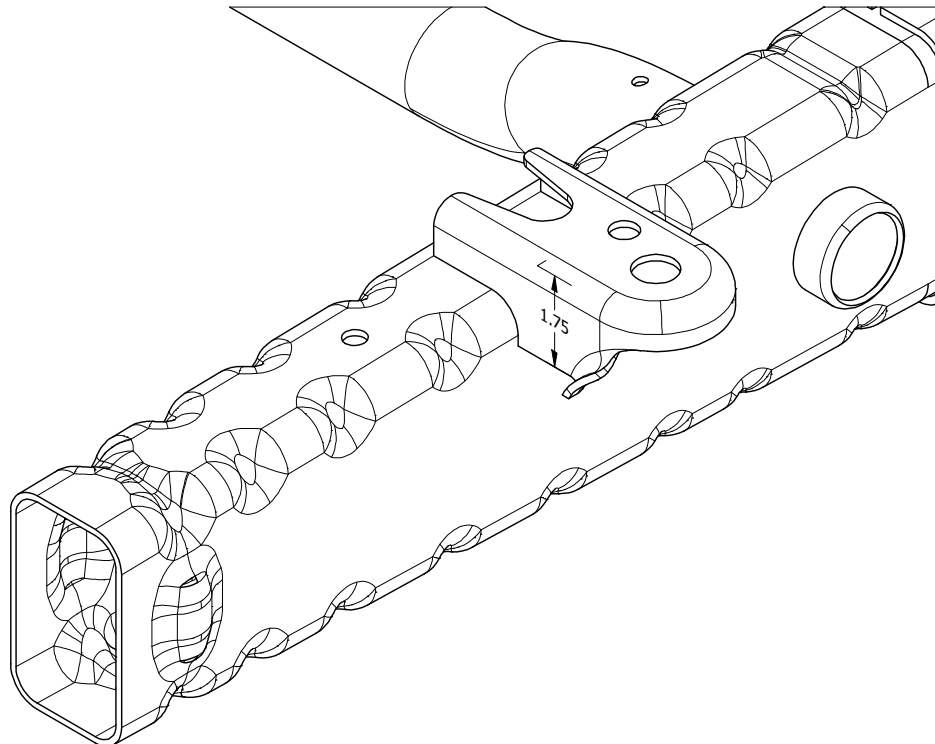

MB1149 - Assembly Instructions

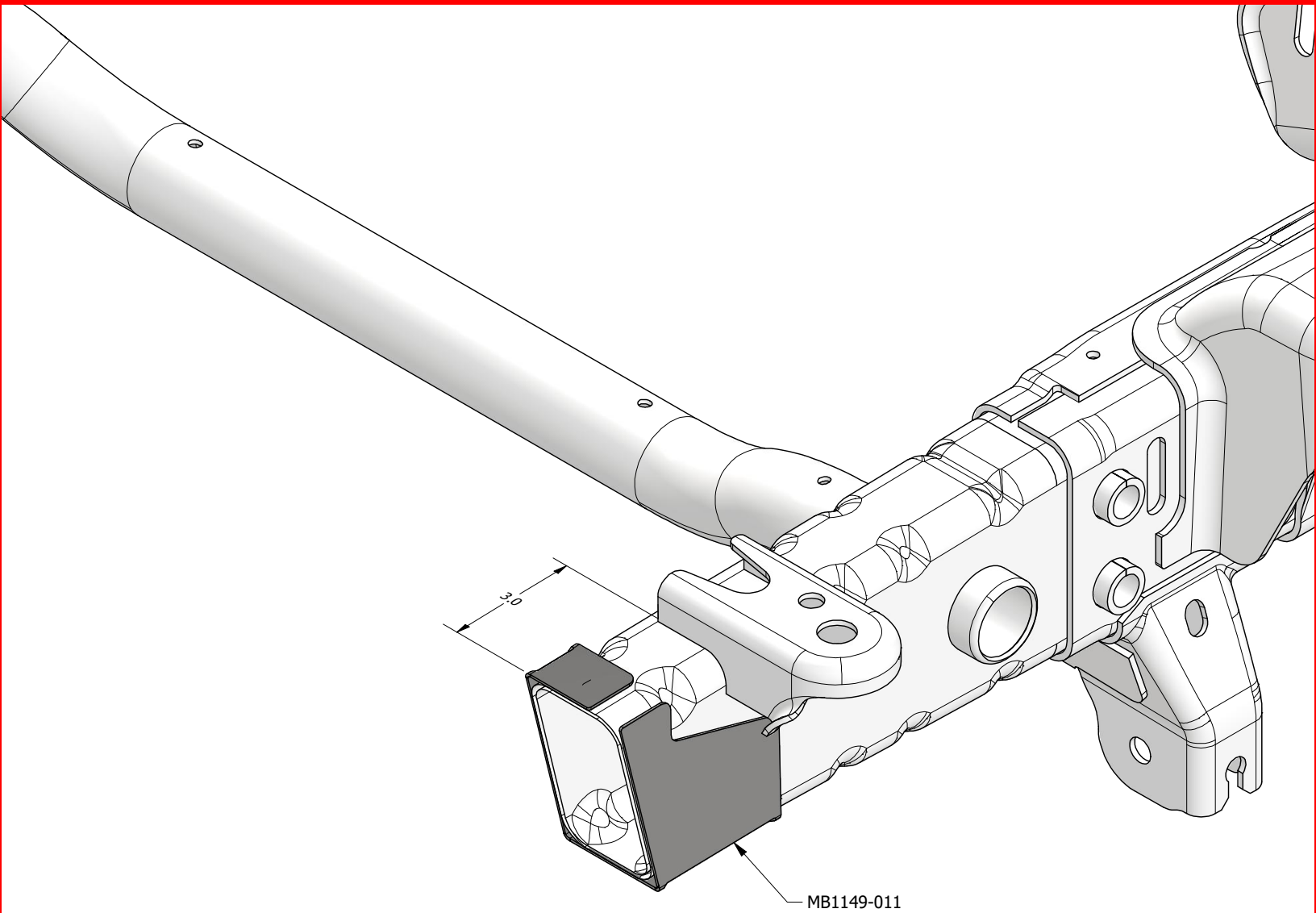

HAND FORM MB1149-011 TO FIT AROUND THE FRAME.
 PLACE IT 3 INCHES FROM THE BODY MOUNT.
 MARK AND CUT THE FRAME FOLLOWING MB1149-011 AS A GUIDE.

MB1149 - Assembly Instructions

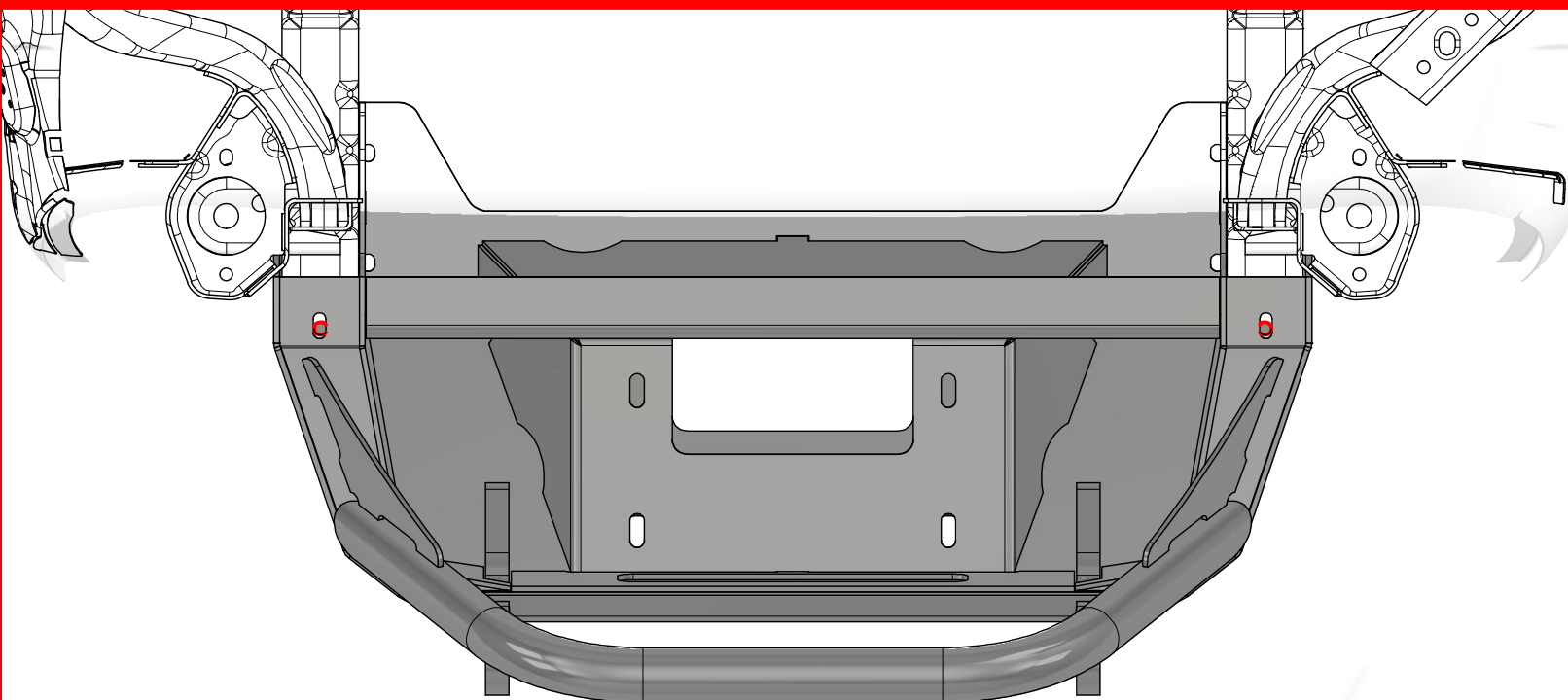

TO LOCATE THE BUMPER, PLACE THE BUMPER ON THE FRAME AND RE INSTALL THE SWAYBAR. FOR THE JL/JT, THE SWAYBAR MOUNT BUSHING WILL NEED TO CUT FLAT.

ONCE INSTALLED, MARK THE HOLE ON THE TOP OF THE BUMPER. REMOVE AND DRILL THE TOP OF THE FRAME WITH A 9/16" DRILL BIT AND INSTALL THE 3/8" U-NUT.

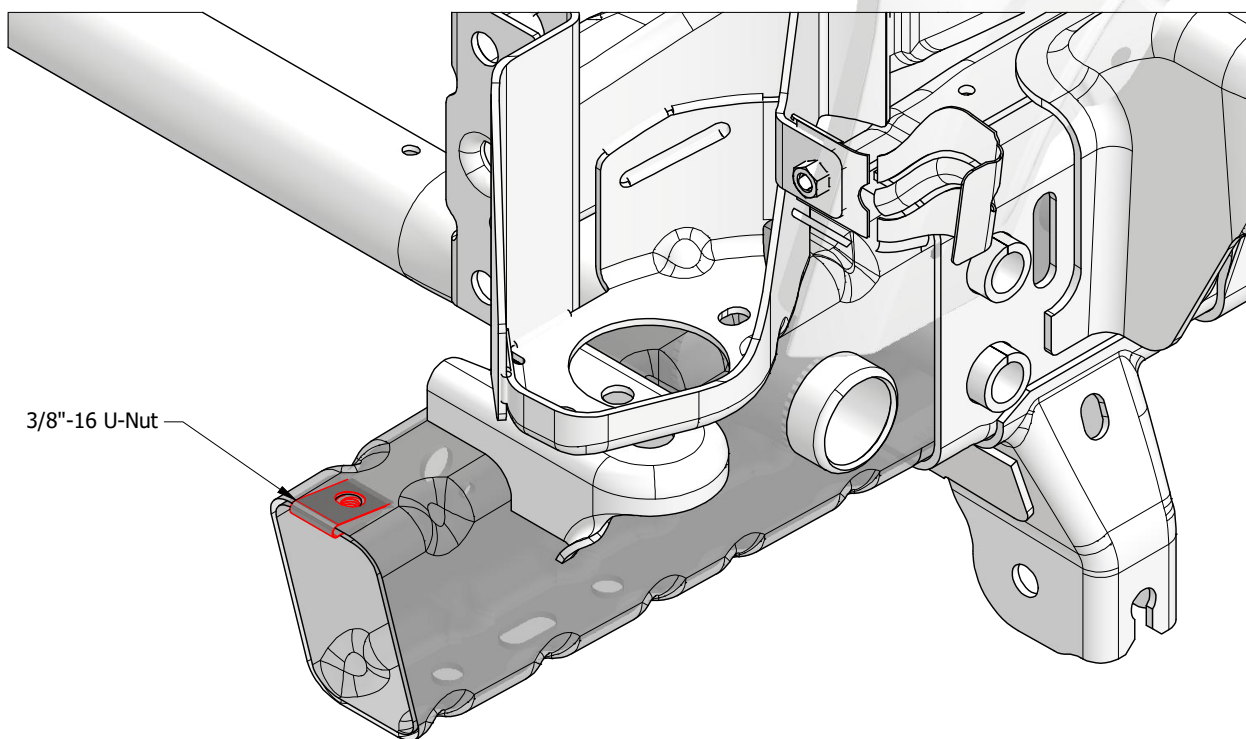

3/8"-16 U-Nut

MB1149 - Assembly Instructions

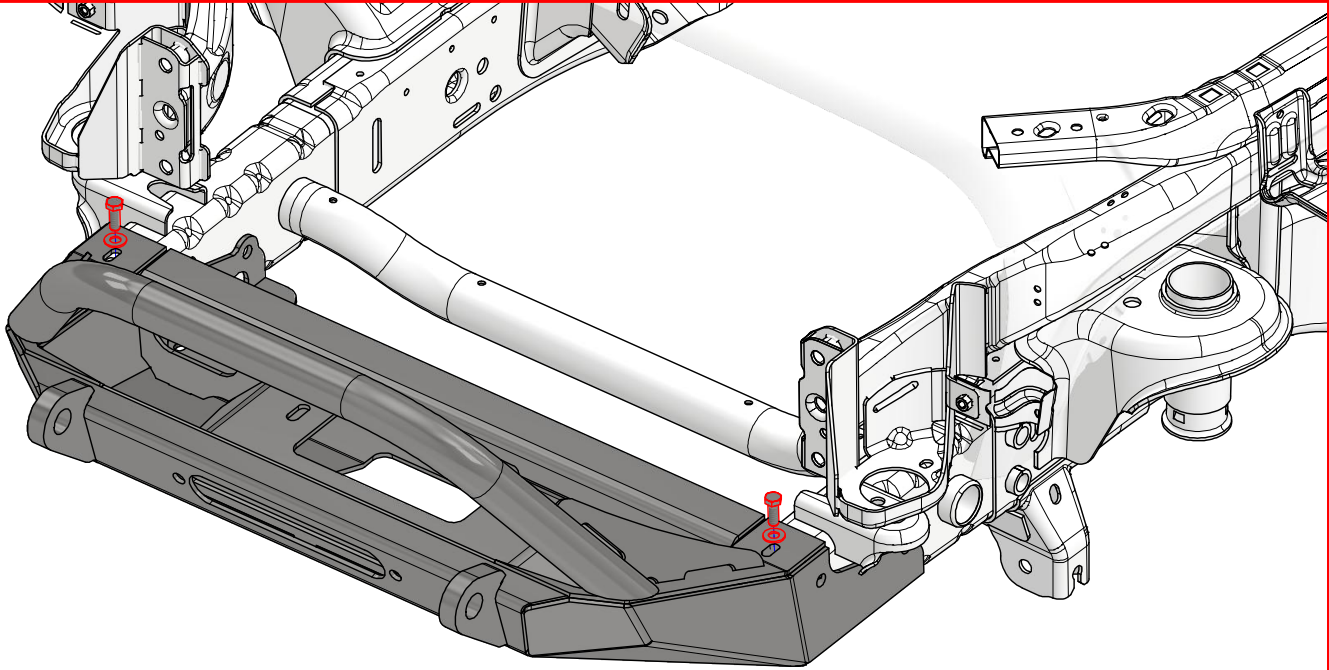

INSTALL BUMPER USING THE 3/8" HARDWARE.
 USE BUMPER AS A TEMPLATE TO MARK AND DRILL 1/2" HOLES
 FOR THE REMAINING MOUNTING HARDWARE

TAKE CARE TO NOT DRILL INTO THE RADIATOR

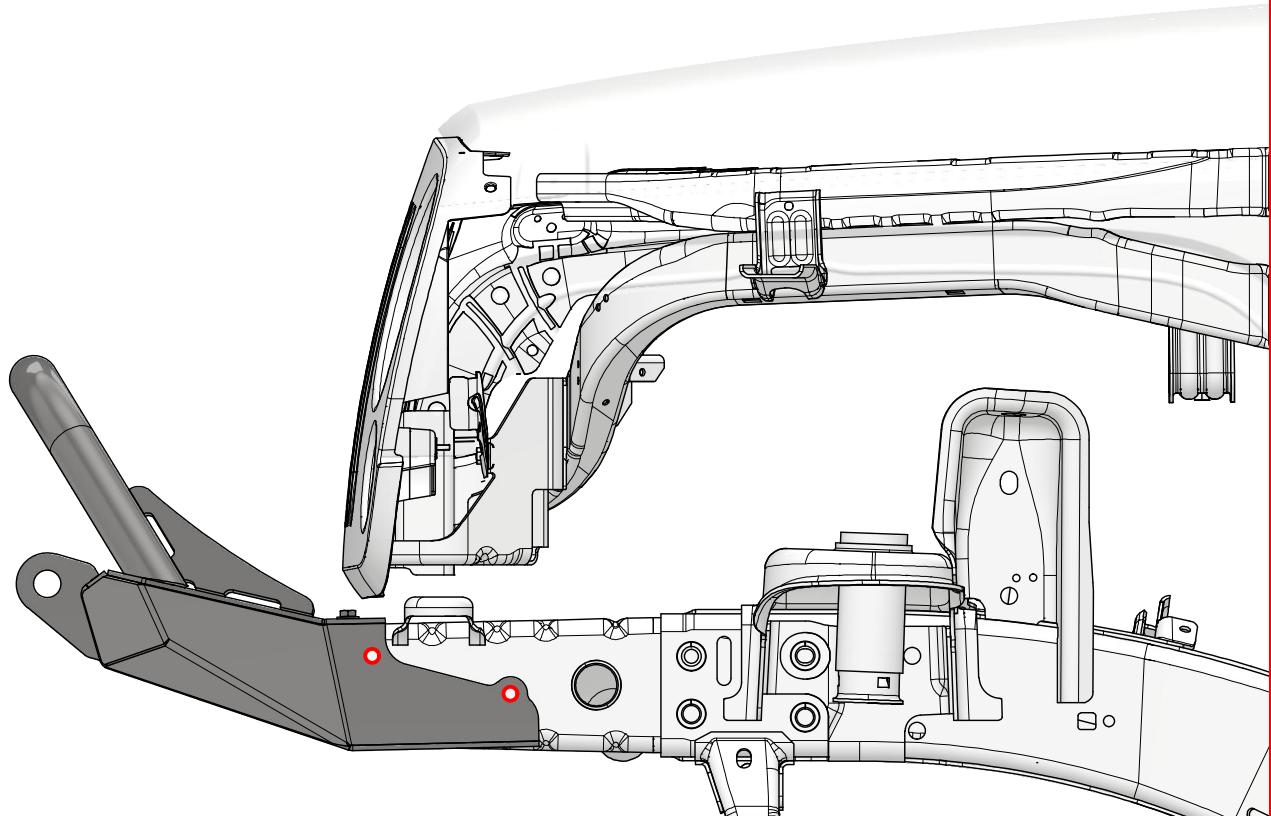

PRO TIP: MARK BOTH THE INSIDE AND OUTSIDE OF EACH FRAME RAIL FOR ACCURATE HOLES.

MB1149 - Assembly Instructions

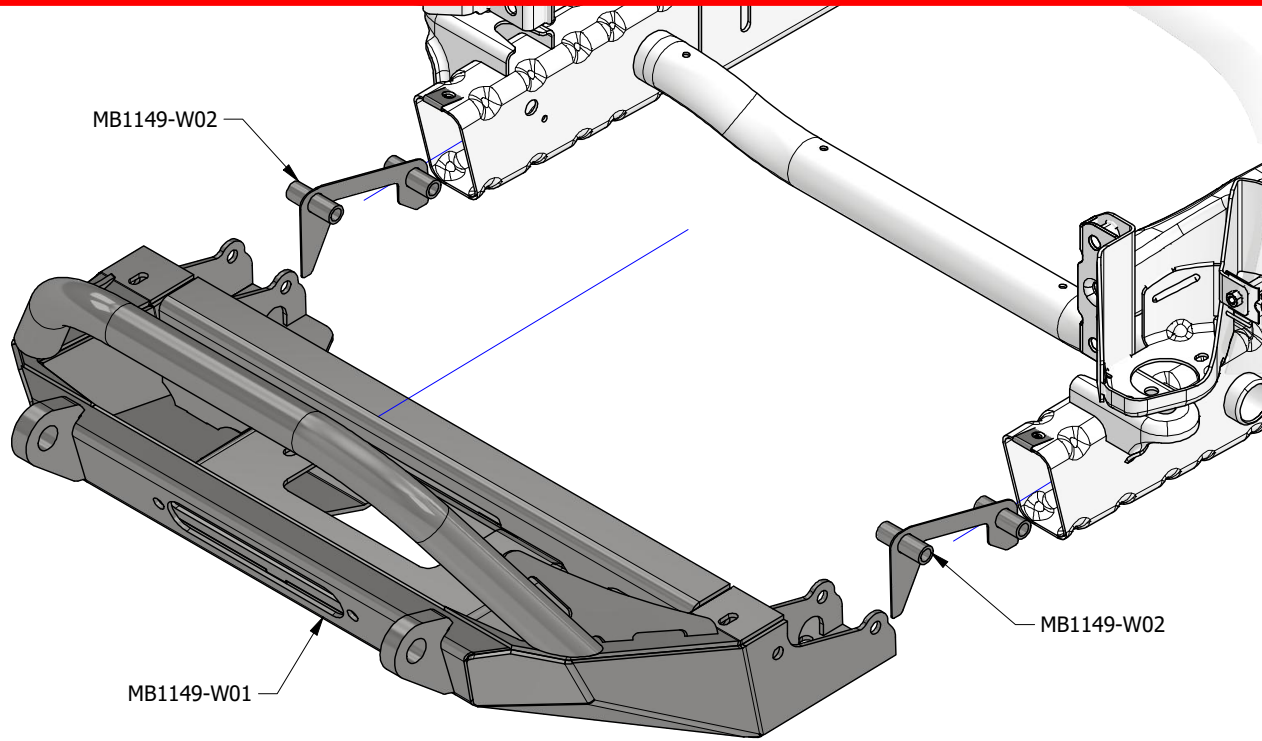

AFTER DRILLING INSERT THE ANTI CRUSH PLATES (MB1149-W02) AND INSTALL BUMPER USING HARDWARE PROVIDED

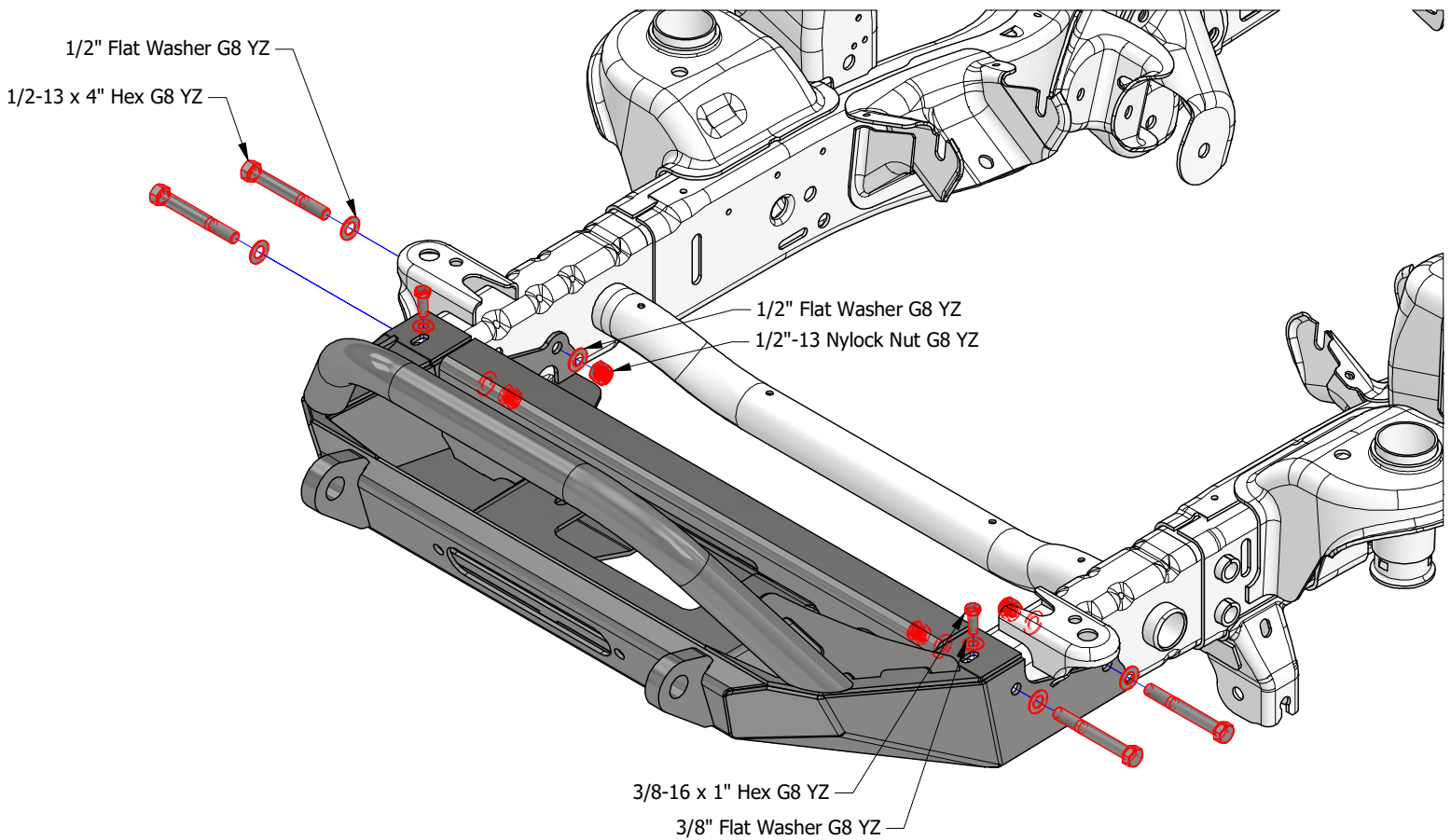

LEGAL DISCLAIMER

Motobilt, Inc. products are designed and manufactured primarily for **OFF-ROAD USE ONLY**. They are not certified or approved for street or highway use and may not comply with vehicle safety standards or regulations. Vehicle modifications, including the installation of Motobilt, Inc. products, may alter the handling, performance, and durability of a vehicle.

By purchasing, installing, or using any Motobilt, Inc. product, the purchaser and installer expressly acknowledge and agree to the following terms:

1. ASSUMPTION OF RISK

The purchaser and installer understand and accept that the installation and use of aftermarket products involve inherent risks, including but not limited to vehicle damage, property damage, serious injury, or death. All such risks are voluntarily assumed.

2. NO WARRANTY OF SAFETY

Motobilt, Inc. makes no representations, warranties, or guarantees, express or implied, regarding the safety, performance, or structural integrity of its products. Motobilt, Inc. products are not intended to prevent injury or death in the event of an accident, rollover, or collision.

3. INSTALLATION RESPONSIBILITY

Some Motobilt products require advanced fabrication, cutting, or welding skills. Others may require specialized tools or mechanical knowledge. Motobilt, Inc. is not responsible for improper installation, modification, or misuse of its products. Professional installation by a qualified individual is strongly recommended.

4. COMPLIANCE WITH LAWS AND REGULATIONS

The purchaser and installer are solely responsible for ensuring that the vehicle and installed products comply with all applicable local, state, and federal laws and safety regulations. Vehicle modifications may void factory warranties and may render the vehicle illegal for use on public roads.

5. MAINTENANCE AND INSPECTION

All products should be inspected regularly for signs of wear, fatigue, or damage. Continued use of damaged or improperly installed equipment increases the risk of failure and potential injury. The responsibility for inspection and maintenance rests solely with the owner and operator.

6. WARRANTY DISCLAIMER

Unless expressly stated in a written limited warranty issued by Motobilt, Inc. for a specific product, all Motobilt, Inc. products are sold "as is" and without express warranties of any kind. If a written limited warranty applies, its terms are exclusive and govern the extent of Motobilt, Inc. obligations.

To the fullest extent permitted by law, Motobilt, Inc. expressly disclaims all implied warranties, including but not limited to implied warranties of merchantability, fitness for a particular purpose, and non-infringement. No oral or written statement by Motobilt, Inc., its employees, dealers, or representatives shall constitute or create any warranty, obligation, or liability beyond what is contained in official written documentation issued by Motobilt, Inc.

7. LIMITATION OF LIABILITY

To the fullest extent permitted by law, Motobilt, Inc. disclaims all liability for any direct, indirect, incidental, consequential, or punitive damages arising out of the purchase, installation, or use of its products. This includes, but is not limited to, claims for property damage, personal injury, loss of use, or loss of income.

8. USER ACKNOWLEDGMENT

By purchasing, installing, or using Motobilt, Inc. products, the purchaser and installer acknowledge that they have read, understood, and accepted the terms of this disclaimer and voluntarily assume all associated risks.