

ODYSSEY[®] BATTERY

Powered by **EnerSys**



Technical Manual

EIGHTH EDITION



www.odysseybattery.com

Publication No: US-ODY-TM-002 - December 2014



Preface to the Eighth Edition

As with previous manuals, this latest edition of the ODYSSEY® Battery technical manual includes detailed performance data for the complete line of ODYSSEY® batteries. Updated test data will help ensure selection of the correct battery for every application.

In addition, this manual includes an expanded section on charging requirements for ODYSSEY batteries. This includes detailed information about the three-step charge profile that will restore a fully discharged battery to optimum power in about 6 to 8 hours.

You may notice that we've updated the look of ODYSSEY batteries to differentiate this premium line in the marketplace. You'll be pleased to know that beneath the surface is the same industry-leading technology, including Thin Plate Pure Lead (TPPL) construction, that has made ODYSSEY batteries the choice of knowledgeable automotive technicians and consumers nationwide.

TABLE OF CONTENTS

Introduction	3
Why use ODYSSEY® batteries?	3
Extended discharge characteristics	4
Performance data tables	4
Cycle Life and Depth of Discharge (DOD)	11
Float Life	11
ODYSSEY® battery storage and deep discharge recovery	11
(A) How do I know the state of charge (SOC) of the battery?	11
(B) How long can the battery be stored?	12
(C) Can the battery recover from abusive storage conditions?	12
(1) German DIN standard test for overdischarge recovery	12
(2) High temperature discharged storage test	12
Parasitic loads	13
Shock, impact and vibration testing	13
(A) Caterpillar™ 100-hour vibration test	13
(B) Shock and vibration test per IEC 61373, Sections 8-10	13
Charging ODYSSEY® batteries	13
(A) Selecting the right charger for your battery	14
(B) Selecting battery type on your charger	15
Rapid charging of ODYSSEY® batteries	15
Load test procedure	16
ODYSSEY® batteries in no-idle applications	16
Parallel connections	17
Ventilation	17
Concluding remarks	17
Frequently asked SLI battery questions	18

INTRODUCTION

The ODYSSEY® battery ingeniously uses Absorbed Glass Mat (AGM) Valve Regulated Lead Acid (VRLA) technology to offer, in one package, the characteristics of two separate batteries. It can deep cycle as well as deliver serious cranking power. Traditional battery designs allow them to either deep cycle or provide high amperage discharges for applications such as engine starting. The ODYSSEY battery can support applications in either category. ODYSSEY batteries are capable of providing engine cranking pulses of up to 2,250A (PC2250) for 5 seconds at 77°F (25°C) as well as deliver 400 charge/discharge cycles to 80% depth of discharge (DOD) when properly charged. A typical starting, lighting and ignition (SLI) battery, for example, is designed to provide short-duration, high-amperage pulses; it performs poorly when repeatedly taken down to deep depths of discharge or if they are placed on a continuous trickle charge, such as when they are used to crank a backup generator. A traditional battery resembles either a sprinter or a long distance runner; an ODYSSEY battery will do both – provide short duration high amperage pulses or low rate, long duration drains.

WHY USE ODYSSEY® BATTERIES?

■ Guaranteed longer service life

With an 8- to 12-year design life in float (emergency power) applications at 77°F (25°C) and a 3- to 10-year service life depending on the nature of the non-float applications, ODYSSEY batteries save you time and money because you do not have to replace them as often. Unlike other AGM VRLA batteries, the ODYSSEY battery is capable of delivering up to 400 cycles when discharged to 80% DOD and properly charged.

■ Longer storage life

Unlike conventional batteries that need a recharge every 6 to 12 weeks, a fully charged ODYSSEY battery can be stored for up to 2 years at 77°F (25°C) from a full state of charge. At lower temperatures, storage times will be even longer.

■ Deep discharge recovery

The ease with which an ODYSSEY battery can recover from a deep discharge is extraordinary. A later section on storage and recharge criteria discusses test data on this important topic.

■ Superior cranking and fast charge capability

The cranking power of ODYSSEY batteries is superior to that of equally sized conventional batteries, even when the temperature is as low as -40°F (-40°C). In addition, with simple constant voltage charging there is no need to limit the inrush current, allowing the battery to be rapidly charged. Please see the section titled *Rapid charging of ODYSSEY batteries* for more details on this feature.

■ Easy shipping

The AGM valve-regulated design of the ODYSSEY battery eliminates the need for vent tubes; further, no battery watering is required and there is no fear of acid burns or damage to expensive chrome or paint. Because of the starved electrolyte design, the ODYSSEY battery has been proven to meet the US Department of Transportation (USDOT) criteria for a non-spillable battery. They can be shipped by highway, air or sea as specified on our MSDS sheet that can be found at www.odysseybattery.com.

■ Tough construction

The rugged construction of the ODYSSEY battery makes it suitable for use in a variety of environments ranging from marine to over-the-road trucks and powersports applications.

■ Mounting flexibility

Installing the ODYSSEY battery in any orientation other than inverted does not affect any performance attribute. There is also no fear of acid spillage.

■ Superior vibration resistance

ODYSSEY batteries have passed a variety of rigorous tests that demonstrate their ruggedness and exceptional tolerance of mechanical abuse. Please see the section titled *Shock, Impact and Vibration testing* for more details on these tests.

■ Ready out of the box

ODYSSEY batteries ship from the factory fully charged. If the battery's open circuit voltage is higher than 12.65V, simply install it in your vehicle and you are ready to go; if below 12.65V boost charge the battery following the instructions in this manual or the owner's manual. For optimum reliability, a boost charge prior to installation is recommended, regardless of the battery's open circuit voltage (OCV).

EXTENDED DISCHARGE CHARACTERISTICS

In addition to its excellent pulse discharge capabilities, the ODYSSEY® battery can deliver many deep discharge cycles, yet another area where the ODYSSEY battery outperforms a conventional SLI battery, which can deliver only a few deep discharge cycles.

The following twenty graphs show detailed discharge characteristics of the entire ODYSSEY battery line. The end of discharge voltage in each case is 10.02V per battery or 1.67 volts per cell (VPC). Each graph shows both constant current (CC) and constant power (CP) discharge curves at 77°F (25°C). The table next to each graph shows the corresponding energy and power densities. The battery run times extend from 2 minutes to 20 hours.

PC310 performance data at 77°F, per 12V module

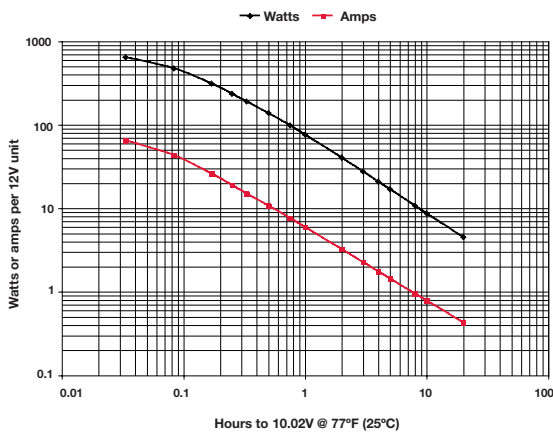

Time	Watts (W)	Amps (A)	Capacity (Ah)	Energy (Wh)	ENERGY AND POWER DENSITIES			
					W/liter	Wh/liter	W/kg	Wh/kg
2 min	738	80.8	2.7	24.6	613.2	20.4	273.3	9.1
5 min	473	43.2	3.6	39.4	393.3	32.8	175.3	14.6
10 min	312	26.0	4.4	53.1	259.4	44.1	115.6	19.7
15 min	236	19.0	4.8	59.0	196.0	49.0	87.4	21.8
20 min	191	15.0	5.0	62.9	158.4	52.3	70.6	23.3
30 min	139	10.8	5.4	69.3	115.1	57.6	51.3	25.7
45 min	98	7.6	5.7	73.9	81.8	61.4	36.5	27.4
1 hr	76	6.0	6.0	76.4	63.5	63.5	28.3	28.3
2 hr	41	3.2	6.5	81.0	33.7	67.3	15.0	30.0
3 hr	28	2.3	6.8	82.8	22.9	68.8	10.2	30.7
4 hr	21	1.8	7.0	83.7	17.4	69.6	7.8	31.0
5 hr	17	1.4	7.2	84.5	14.0	70.2	6.3	31.3
8 hr	11	0.9	7.6	86.1	8.9	71.5	4.0	31.9
10 hr	9	0.8	7.8	86.8	7.2	72.1	3.2	32.2
20 hr	5	0.4	8.6	90.5	3.8	75.2	1.7	33.5

PC370 performance data at 77°F, per 12V module

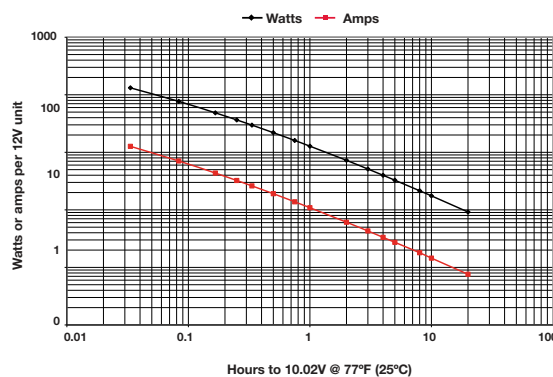

Time	Watts (W)	Amps (A)	Capacity (Ah)	Energy (Wh)	ENERGY AND POWER DENSITIES			
					W/litre	Wh/litre	W/kg	Wh/kg
2 min	1320	127.1	4.2	44.0	612.2	20.4	231.6	7.7
5 min	768	70.7	5.9	64.0	356.2	29.7	134.7	11.2
10 min	485	43.6	7.3	80.9	225.1	37.5	85.2	14.2
15 min	365	32.4	8.1	91.4	169.5	42.4	64.1	16.0
20 min	297	26.1	8.7	99.0	137.8	45.9	52.1	17.4
30 min	220	19.1	9.6	109.8	101.9	50.9	38.5	19.3
45 min	161	13.8	10.4	120.6	74.6	55.9	28.2	21.2
1 hr	128	10.9	10.9	127.8	59.3	59.3	22.4	22.4
2 hr	73	6.1	12.2	145.2	33.7	67.3	12.7	25.5
3 hr	51	4.3	12.9	153.7	23.8	71.3	9.0	27.0
4 hr	40	3.3	13.3	159.6	18.5	74.0	7.0	28.0
5 hr	33	2.7	13.7	163.8	15.2	76.0	5.7	28.7
8 hr	21	1.8	14.4	171.8	10.0	79.7	3.8	30.1
10 hr	18	1.5	14.5	175.2	8.1	81.3	3.1	30.7
20 hr	9	0.8	15.2	183.6	4.3	85.2	1.6	32.2

Time	Watts (W)	Amps (A)	Capacity (Ah)	Energy (Wh)	ENERGY AND POWER DENSITIES			
					W/liter	Wh/liter	W/kg	Wh/kg
2 min	1182	112.0	3.40	35.5	450.7	13.5	218.9	6.6
5 min	786	71.9	5.75	62.9	299.7	24.0	145.6	11.6
10 min	517	46.3	7.90	87.9	197.2	33.5	98.8	16.3
15 min	391	34.5	8.60	97.7	148.9	37.2	72.3	18.1
20 min	316	27.7	9.10	104.4	120.6	39.8	58.6	19.3
30 min	230	20.0	10.0	115.2	87.9	43.9	42.7	21.3
45 min	165	14.2	10.7	123.8	62.9	47.2	30.6	22.9
1 hr	129	11.0	11.0	129.0	49.2	49.2	23.9	23.9
2 hr	70	5.9	11.8	140.4	26.8	53.5	13.0	26.0
3 hr	49	4.1	12.3	145.4	18.5	55.5	9.0	26.9
4 hr	37	3.1	12.4	149.3	14.2	56.9	6.9	27.6
5 hr	31	2.5	12.5	152.4	11.6	58.1	5.6	28.2
8 hr	19	1.7	13.6	159.4	7.6	60.8	3.7	29.5
10 hr	16	1.3	13.0	163.2	6.2	62.2	3.0	30.2
20 hr	9	0.74	14.8	178.8	3.4	68.2	1.7	33.1

PC535 performance data at 77°F, per 12V module

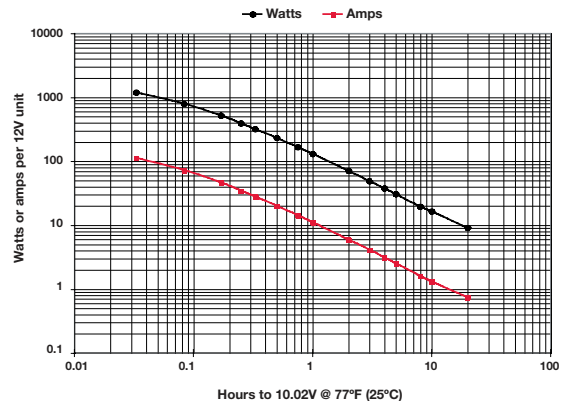

Time	Watts (W)	Amps (A)	Capacity (Ah)	Energy (Wh)	ENERGY AND POWER DENSITIES			
					W/liter	Wh/liter	W/kg	Wh/kg
2 min	1361	128.1	4.3	45.3	680.8	22.7	238.7	8.0
5 min	648	64.4	5.4	54.0	324.2	27.0	113.7	9.5
10 min	415	39.6	6.7	70.6	207.8	35.3	72.8	12.4
15 min	313	29.2	7.3	78.2	156.4	39.1	54.8	13.7
20 min	254	23.5	7.8	83.8	127.0	41.9	44.5	14.7
30 min	187	16.9	8.5	93.3	93.4	46.7	32.7	16.4
45 min	136	12.2	9.2	101.7	67.9	50.9	23.8	17.8
1 hr	107	9.6	9.6	107.4	53.7	53.7	18.8	18.8
2 hr	60	5.3	10.6	120.0	30.0	60.0	10.5	21.1
3 hr	42	3.7	11.1	126.0	21.0	63.1	7.4	22.1
4 hr	32	2.9	11.6	129.6	16.2	64.9	5.7	22.7
5 hr	26	2.3	11.5	132.0	13.2	66.1	4.6	23.2
8 hr	17	1.5	12.0	134.4	8.4	67.3	3.0	23.6
10 hr	14	1.2	12.0	138.0	6.9	69.1	2.4	24.2
20 hr	7	0.7	14.0	144.0	3.6	72.1	1.3	25.3

PC545 performance data at 77°F, per 12V module

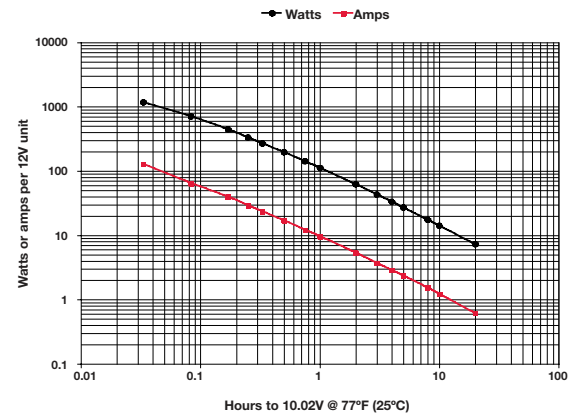

Time	Watts (W)	Amps (A)	Capacity (Ah)	Energy (Wh)	ENERGY AND POWER DENSITIES			
					W/liter	Wh/liter	W/kg	Wh/kg
2 min	1582	154.7	5.2	52.7	536.1	17.9	255.1	8.5
5 min	986	91.6	7.6	82.2	334.4	27.9	159.1	13.3
10 min	635	57.1	9.5	105.9	215.4	35.9	102.5	17.1
15 min	478	42.3	10.6	119.4	161.9	40.5	77.0	19.3
20 min	385	33.8	11.3	128.4	130.6	43.5	62.1	20.7
30 min	281	24.4	12.2	140.7	95.4	47.7	45.4	22.7
45 min	202	17.4	13.1	151.7	68.5	51.4	32.6	24.5
1 hr	159	13.6	13.6	159.0	53.9	53.9	25.7	25.7
2 hr	87	7.3	14.6	174.0	29.5	59.0	14.0	28.1
3 hr	61	5.1	15.3	181.8	20.5	61.6	9.8	29.3
4 hr	47	3.9	15.6	187.2	15.9	63.5	7.6	30.2
5 hr	38	3.2	16.0	192.0	13.0	65.1	6.2	31.0
8 hr	25	2.1	16.8	201.6	8.5	68.3	4.1	32.5
10 hr	20	1.7	17.0	204.0	6.9	69.2	3.3	32.9
20 hr	11	0.9	18.0	216.0	3.7	73.2	1.7	34.8

PC625 performance data at 77°F, per 12V module

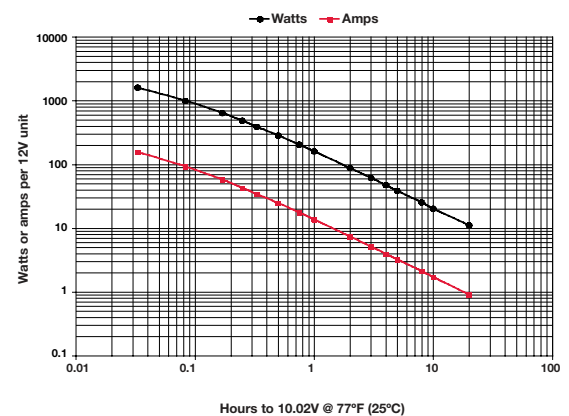

PC680 performance data at 77°F, per 12V module

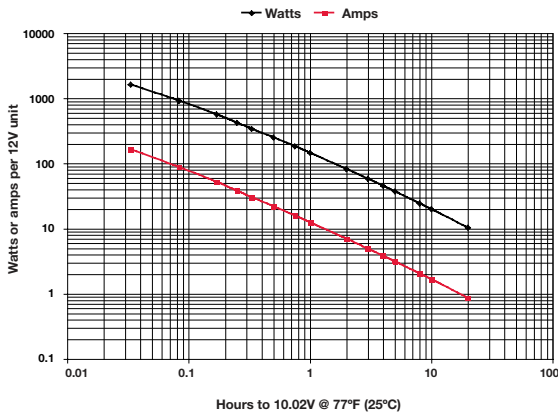

Time	Watts (W)	Amps (A)	Capacity (Ah)	Energy (Wh)	ENERGY AND POWER DENSITIES			
					W/liter	Wh/liter	W/kg	Wh/kg
2 min	1486	143.0	4.8	49.5	601.4	20.0	212.3	7.1
5 min	792	78.8	6.6	66.0	320.5	26.7	113.1	9.4
10 min	512	49.3	8.4	87.1	207.3	35.3	73.2	12.4
15 min	389	36.7	9.2	97.4	157.6	39.4	55.6	13.9
20 min	318	29.6	9.8	104.9	128.7	42.5	45.4	15.0
30 min	236	21.6	10.8	118.2	95.7	47.8	33.8	16.9
45 min	173	15.6	11.7	130.1	70.2	52.6	24.8	18.6
1 hr	138	12.3	12.3	138.0	55.8	55.8	19.7	19.7
2 hr	79	6.9	13.8	157.2	31.8	63.6	11.2	22.5
3 hr	56	4.8	14.4	166.5	22.5	67.4	7.9	23.8
4 hr	43	3.7	14.8	172.8	17.5	69.9	6.2	24.7
5 hr	35	3.0	15.0	177.0	14.3	71.6	5.1	25.3
8 hr	23	2.0	16.0	187.2	9.5	75.8	3.3	26.7
10 hr	19	1.6	16.0	192.0	7.8	77.7	2.7	27.4
20 hr	10	0.8	16.0	204.0	4.1	82.6	1.5	29.1

PC925 performance data at 77°F, per 12V module

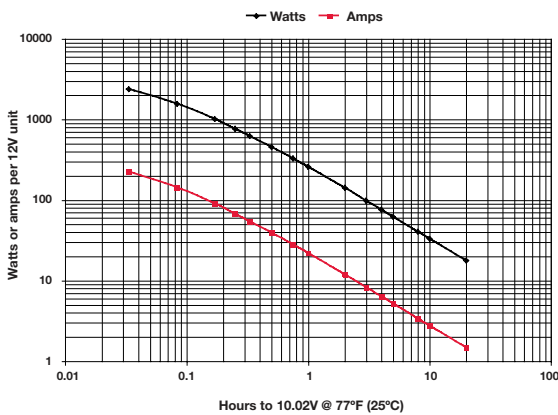

Time	Watts (W)	Amps (A)	Capacity (Ah)	Energy (Wh)	ENERGY AND POWER DENSITIES			
					W/liter	Wh/liter	W/kg	Wh/kg
2 min	2381	224.8	7.5	79.3	615.8	20.5	201.8	6.7
5 min	1446	142.8	11.9	120.5	374.0	31.2	122.5	10.2
10 min	954	90.6	15.4	162.2	246.8	42.0	80.9	13.7
15 min	726	67.4	16.9	181.5	187.8	46.9	61.5	15.4
20 min	592	54.2	17.9	195.2	153.0	50.5	50.1	16.5
30 min	436	39.2	19.6	217.8	112.7	56.3	36.9	18.5
45 min	316	28.1	21.1	236.7	81.6	61.2	26.8	20.1
1 hr	250	21.9	21.9	249.6	64.6	64.6	21.2	21.2
2 hr	138	11.9	23.8	276.0	35.7	71.4	11.7	23.4
3 hr	96	8.3	24.9	288.0	24.8	74.5	8.1	24.4
4 hr	74	6.4	25.6	297.6	19.2	77.0	6.3	25.2
5 hr	61	5.2	26.0	303.0	15.7	78.4	5.1	25.7
8 hr	40	3.4	27.2	316.8	10.2	81.9	3.4	26.9
10 hr	32	2.8	27.5	324.0	8.4	83.8	2.8	27.5
20 hr	17	1.5	30.0	348.0	4.5	90.0	1.5	29.5

PC950 performance data at 77°F, per 12V module

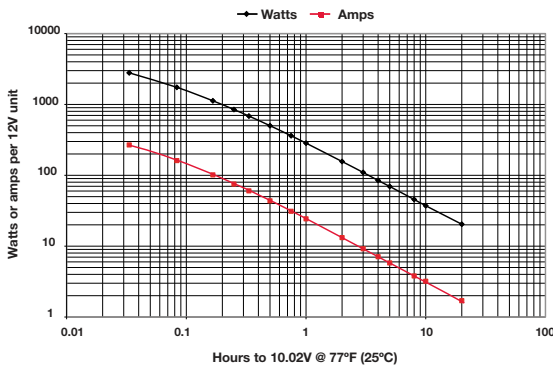

Time	Watts (W)	Amps (A)	Capacity (Ah)	Energy (Wh)	ENERGY AND POWER DENSITIES			
					W/litre	Wh/litre	W/kg	Wh/kg
2 min	2794	268.3	8.9	93.1	755.0	25.2	310.4	10.3
5 min	1745	161.3	13.4	145.4	471.6	39.3	193.9	16.2
10 min	1126	101.4	16.9	187.7	304.4	50.7	125.1	20.9
15 min	848	75.3	18.8	212.0	229.1	57.3	94.2	23.6
20 min	686	60.3	20.1	228.6	185.4	61.8	76.2	25.4
30 min	502	43.6	21.8	250.8	135.6	67.8	55.7	27.9
45 min	362	31.1	23.3	271.4	97.8	73.3	40.2	30.2
1 hr	284	24.3	24.3	284.4	76.9	76.9	31.6	31.6
2 hr	157	13.2	26.4	313.2	42.3	84.6	17.4	34.8
3 hr	110	9.2	27.6	329.4	29.7	89.0	12.2	36.6
4 hr	85	7.1	28.4	338.4	22.9	91.5	9.4	37.6
5 hr	70	5.8	29.0	348.0	18.8	94.1	7.7	38.7
8 hr	46	3.8	30.4	364.8	12.3	98.6	5.1	40.5
10 hr	37	3.2	32.0	372.0	10.1	100.5	4.1	41.3
20 hr	20	1.7	34.0	408.0	5.5	110.3	2.3	45.3

Time	Watts (W)	Amps (A)	Capacity (Ah)	Energy (Wh)	ENERGY AND POWER DENSITIES			
					W/litre	Wh/litre	W/kg	Wh/kg
2 min	3307	326.8	10.9	110.2	668.1	22.3	264.6	8.8
5 min	2333	219.5	18.3	194.4	471.3	39.3	186.6	15.6
10 min	1575	143.2	23.9	262.5	318.2	53.0	126.0	21.0
15 min	1200	107.2	26.8	300.0	242.4	60.6	96.0	24.0
20 min	974	86.1	28.7	324.8	196.8	65.6	78.0	26.0
30 min	713	62.0	31.0	356.7	144.1	72.1	57.1	28.5
45 min	513	44.0	33.0	384.8	103.6	77.7	41.0	30.8
1 hr	403	34.3	34.3	402.6	81.3	81.3	32.2	32.2
2 hr	221	18.5	37.0	441.6	44.6	89.2	17.7	35.3
3 hr	154	12.9	38.7	462.6	31.2	93.5	12.3	37.0
4 hr	120	10.0	40.0	480.0	24.2	97.0	9.6	38.4
5 hr	99	8.2	41.0	495.0	20.0	100.0	7.9	39.6
8 hr	66	5.5	44.0	528.0	13.3	106.7	5.3	42.2
10 hr	55	4.6	46.0	552.0	11.2	111.5	4.4	44.2
20 hr	32	2.7	54.0	648.0	6.5	130.9	2.6	51.8

PC1100 performance data at 77°F, per 12V module

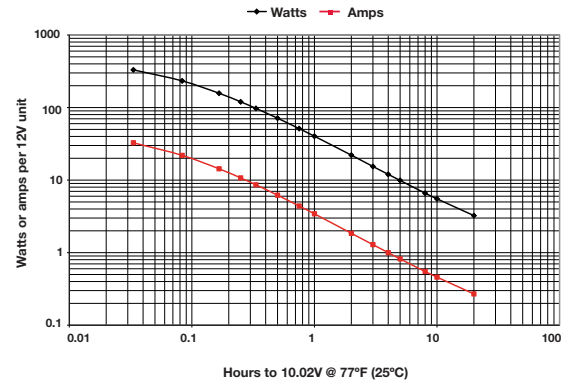

Time	Watts (W)	Amps (A)	Capacity (Ah)	Energy (Wh)	ENERGY AND POWER DENSITIES			
					W/liter	Wh/liter	W/kg	Wh/kg
2 min	3580	337.9	11.3	119.2	613.0	20.4	205.8	6.9
5 min	1992	199.1	16.6	165.9	341.1	28.4	114.5	9.5
10 min	1338	127.9	21.7	227.5	229.1	38.9	76.9	13.1
15 min	1026	96.0	24.0	256.5	175.7	43.9	59.0	14.7
20 min	840	77.5	25.6	277.2	143.8	47.5	48.3	15.9
30 min	624	56.6	28.3	312.0	106.8	53.4	35.9	17.9
45 min	458	40.8	30.6	343.4	78.4	58.8	26.3	19.7
1 hr	364	32.1	32.1	363.6	62.3	62.3	20.9	20.9
2 hr	203	17.7	35.4	406.8	34.8	69.7	11.7	23.4
3 hr	143	12.3	36.9	428.4	24.5	73.4	8.2	24.6
4 hr	110	9.5	38.0	441.6	18.9	75.6	6.3	25.4
5 hr	91	7.7	38.5	453.0	15.5	77.6	5.2	26.0
8 hr	59	5.0	40.0	475.2	10.2	81.4	3.4	27.3
10 hr	48	4.1	41.0	480.0	8.2	82.2	2.8	27.6
20 hr	25	2.2	44.0	504.0	4.3	86.3	1.5	29.0

PC1200 performance data at 77°F, per 12V module

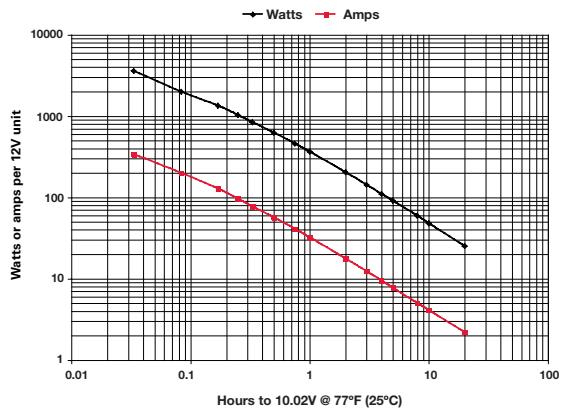

Time	Watts (W)	Amps (A)	Capacity (Ah)	Energy (Wh)	ENERGY AND POWER DENSITIES			
					W/litre	Wh/litre	W/kg	Wh/kg
2 min	3982	384.3	12.8	132.7	396.6	13.2	192.4	6.4
5 min	2846	264.8	22.1	237.2	283.5	23.6	137.5	11.5
10 min	1993	180.8	30.1	332.1	198.5	33.1	96.3	16.0
15 min	1561	139.7	34.9	390.3	155.5	38.9	75.4	18.9
20 min	1294	114.8	38.3	431.4	128.9	43.0	62.5	20.8
30 min	976	85.5	42.8	487.9	97.2	48.6	47.1	23.6
45 min	722	62.6	46.9	541.2	71.9	53.9	34.9	26.1
1 hr	577	49.7	49.7	576.6	57.4	57.4	27.9	27.9
2 hr	326	27.7	55.4	652.1	32.5	64.9	15.8	31.5
3 hr	230	19.4	58.3	689.8	22.9	68.7	11.1	33.3
4 hr	179	15.0	60.1	714.0	17.8	71.1	8.6	34.5
5 hr	146	12.3	61.5	731.6	14.6	72.9	7.1	35.3
8 hr	96	8.0	64.2	766.2	9.5	76.3	4.6	37.0
10 hr	78	6.5	65.5	782.0	7.8	77.9	3.8	37.8
20 hr	42	3.5	69.9	832.1	4.1	82.9	2.0	40.2

PC1220 performance data at 77°F, per 12V module

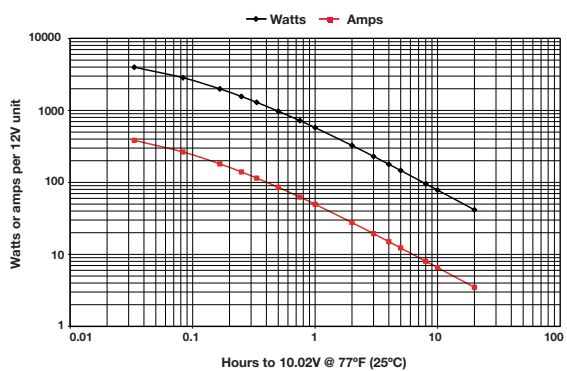

75-PC1230 & 75/86-PC1230 performance data at 77°F, per 12V module

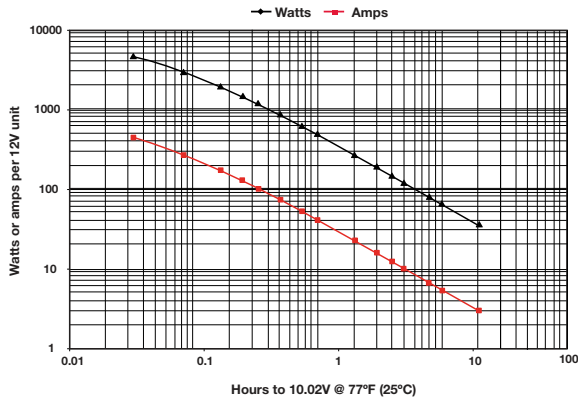

Time	Watts (W)	Amps (A)	Capacity (Ah)	Energy (Wh)	ENERGY AND POWER DENSITIES			
					W/litre	Wh/litre	W/kg	Wh/kg
2 min	4562	432.9	14.3	150.5	531.5	17.5	221.4	7.3
5 min	2936	266.5	22.1	243.7	342.1	28.4	142.5	11.8
10 min	1919	169.6	28.3	320.5	223.6	37.3	93.2	15.6
15 min	1451	126.6	31.7	362.8	169.1	42.3	70.4	17.6
20 min	1176	101.8	33.9	391.6	137.0	45.6	57.1	19.0
30 min	862	73.8	36.9	430.8	100.4	50.2	41.8	20.9
45 min	622	52.8	39.6	466.4	72.5	54.3	30.2	22.6
1 hr	490	41.4	41.4	489.8	57.1	57.1	23.8	23.8
2 hr	270	22.6	45.3	540.2	31.5	62.9	13.1	26.2
3 hr	189	15.8	47.4	567.1	22.0	66.1	9.2	27.5
4 hr	146	12.2	48.8	585.7	17.1	68.2	7.1	28.4
5 hr	120	10.0	50.0	600.6	14.0	70.0	5.8	29.2
8 hr	79	6.6	52.7	633.2	9.2	73.8	3.8	30.7
10 hr	65	5.4	54.1	650.1	7.6	75.7	3.2	31.6
20 hr	36	3.0	59.4	713.5	4.2	83.1	1.7	34.6

PC1350 performance data at 77°F, per 12V module

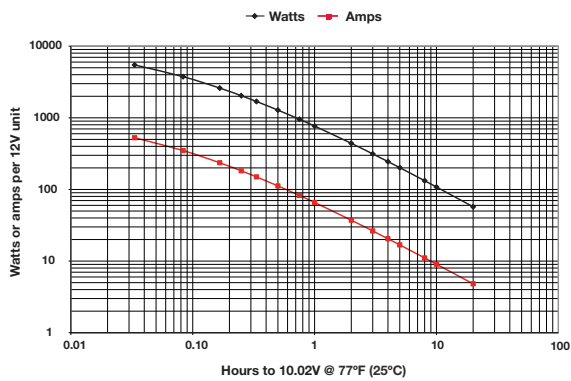

Time	Watts (W)	Amps (A)	Capacity (Ah)	Energy (Wh)	ENERGY AND POWER DENSITIES			
					W/litre	Wh/litre	W/kg	Wh/kg
2 min	5477	527.2	17.6	182.6	438.2	14.6	199.9	6.7
5 min	3758	349.4	29.1	313.2	300.7	25.1	137.2	11.4
10 min	2602	235.8	39.3	433.6	208.1	34.7	94.9	15.8
15 min	2037	182.0	45.5	509.3	163.0	40.7	74.3	18.6
20 min	1692	149.8	49.9	564.0	135.4	45.1	61.7	20.6
30 min	1282	112.1	56.0	641.0	102.6	51.3	46.8	23.4
45 min	955	82.5	61.9	716.2	76.4	57.3	34.9	26.1
1 hr	768	65.8	65.8	767.6	61.4	61.4	28.0	28.0
2 hr	441	37.3	74.5	881.7	35.3	70.5	16.1	32.2
3 hr	314	26.4	79.1	940.8	25.1	75.3	11.4	34.3
4 hr	245	20.5	82.0	979.2	19.6	78.3	8.9	35.7
5 hr	201	16.8	84.2	1006.9	16.1	80.5	7.3	36.7
8 hr	133	11.1	88.5	1059.8	10.6	84.8	4.8	38.7
10 hr	108	9.0	90.5	1082.7	8.7	86.6	4.0	39.5
20 hr	57	4.8	96.5	1146.8	4.6	91.7	2.1	41.9

25-PC1400 & 35-PC1400 performance data at 77°F, per 12V module

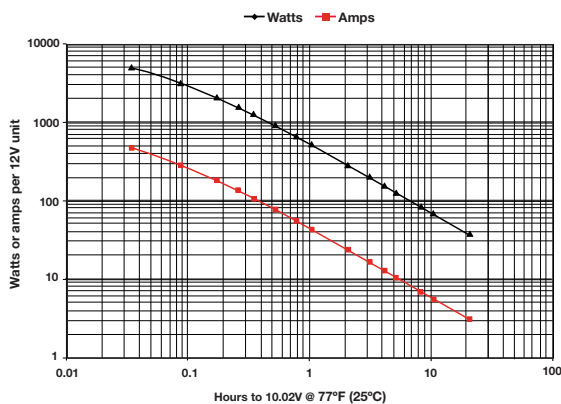

Time	Watts (W)	Amps (A)	Capacity (Ah)	Energy (Wh)	ENERGY AND POWER DENSITIES			
					W/litre	Wh/litre	W/kg	Wh/kg
2 min	5308	499.5	16.5	175.2	576.1	19.0	233.8	7.7
5 min	3440	315.8	26.2	285.5	373.3	31.0	151.5	12.6
10 min	2261	203.0	33.9	377.7	245.4	41.0	99.6	16.6
15 min	1716	151.9	38.0	428.9	186.2	46.5	75.6	18.9
20 min	1393	122.2	40.7	463.9	151.2	50.3	61.4	20.4
30 min	1023	88.6	44.3	511.5	111.0	55.5	45.1	22.5
45 min	739	63.3	47.4	554.5	80.2	60.2	32.6	24.4
1 hr	583	49.4	49.4	582.5	63.2	63.2	25.7	25.7
2 hr	321	26.8	53.6	641.2	34.8	69.6	14.1	28.2
3 hr	224	18.6	55.7	671.0	24.3	72.8	9.9	29.6
4 hr	173	14.3	57.2	690.5	18.7	74.9	7.6	30.4
5 hr	141	11.7	58.4	705.4	15.3	76.5	6.2	31.1
8 hr	92	7.6	61.0	736.6	10.0	79.9	4.1	32.4
10 hr	75	6.2	62.5	751.9	8.2	81.6	3.3	33.1
20 hr	40	3.4	67.9	805.5	4.4	87.4	1.8	35.5

Time	Watts (W)	Amps (A)	Capacity (Ah)	Energy (Wh)	ENERGY AND POWER DENSITIES			
					W/liter	Wh/liter	W/kg	Wh/kg
2 min	5228	494.8	16.3	172.5	538.1	17.8	209.9	6.9
5 min	3337	304.4	25.3	277.0	343.5	28.5	134.0	11.1
10 min	2175	193.6	32.3	363.3	223.9	37.4	87.4	14.6
15 min	1644	144.5	36.1	411.0	169.2	42.3	66.0	16.5
20 min	1332	116.1	38.7	443.7	137.2	45.7	53.5	17.8
30 min	977	84.2	42.1	488.4	100.5	50.3	39.2	19.6
45 min	706	60.3	45.2	529.3	72.6	54.5	28.3	21.3
1 hr	556	47.3	47.3	556.2	57.3	57.3	22.3	22.3
2 hr	307	25.9	51.7	615.0	31.7	63.3	12.3	24.7
3 hr	215	18.1	54.2	646.5	22.2	66.5	8.7	26.0
4 hr	167	14.0	56.0	668.4	17.2	68.8	6.7	26.8
5 hr	137	11.5	57.4	685.4	14.1	70.6	5.5	27.5
8 hr	90	7.6	60.6	723.1	9.3	74.4	3.6	29.0
10 hr	74	6.2	62.3	742.5	7.6	76.4	3.0	29.8
20 hr	41	3.3	65.0	814.0	4.2	83.8	1.6	32.7

34-PC1500, 34R-PC1500, 34M-PC1500, 34/78-PC1500 & 78-PC1500 performance data at 77°F, per 12V module

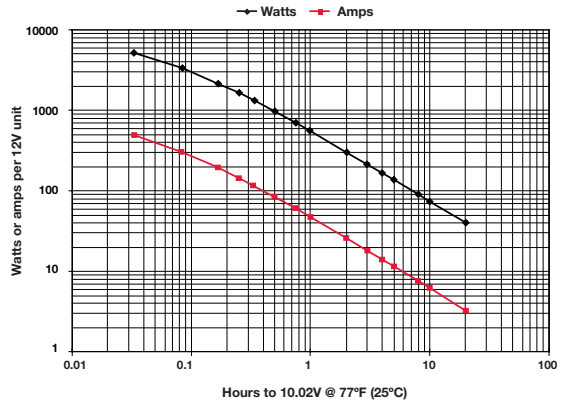

Time	Watts (W)	Amps (A)	Capacity (Ah)	Energy (Wh)	ENERGY AND POWER DENSITIES			
					W/liter	Wh/liter	W/kg	Wh/kg
2 min	5942	569.8	19.0	197.9	607.0	20.2	215.3	7.2
5 min	3636	337.6	28.1	279.9	343.3	28.6	121.7	10.1
10 min	2411	218.5	37.2	384.5	231.1	39.3	82.0	13.9
15 min	1833	163.8	41.0	433.5	177.2	44.3	62.8	15.7
20 min	1490	132.6	43.7	467.3	144.7	47.7	51.3	16.9
30 min	1091	96.0	48.0	522.0	106.7	53.3	37.8	18.9
45 min	786	68.6	51.4	567.0	77.2	57.9	27.4	20.5
1 hr	615	53.6	53.6	594.6	60.8	60.8	21.5	21.5
2 hr	333	28.9	57.8	648.0	33.1	66.2	11.7	23.5
3 hr	229	19.9	59.6	671.4	22.9	68.6	8.1	24.3
4 hr	175	15.2	61.0	684.0	17.5	69.9	6.2	24.8
5 hr	142	12.4	61.8	693.0	14.2	70.8	5.0	25.1
8 hr	90	8.0	63.6	705.6	9.0	72.1	3.2	25.6
10 hr	73	6.5	64.5	714.0	7.3	72.9	2.6	25.9
20 hr	37	3.4	67.9	732.0	3.7	74.8	1.3	26.5

PC1700 performance data at 77°F, per 12V module

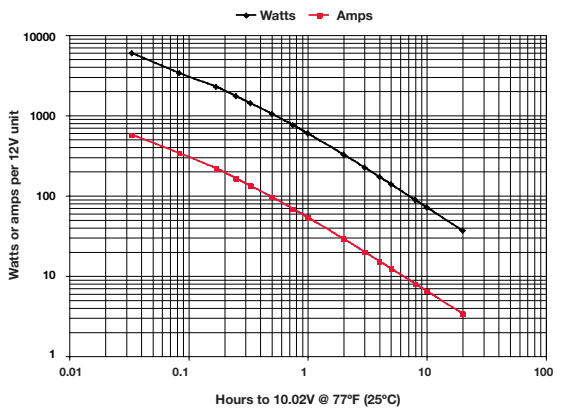

Time	Watts (W)	Amps (A)	Capacity (Ah)	Energy (Wh)	ENERGY AND POWER DENSITIES			
					W/litre	Wh/litre	W/kg	Wh/kg
2 min	5890	565.9	18.7	194.4	567.9	18.7	224.0	7.4
5 min	3770	334.2	27.7	312.9	363.5	30.2	143.3	11.9
10 min	2440	210.9	35.2	407.4	235.2	39.3	92.8	15.5
15 min	1832	157.7	39.4	458.0	176.6	44.2	69.7	17.4
20 min	1477	127.2	42.4	491.9	142.4	47.4	56.2	18.7
30 min	1076	93.0	46.5	537.9	103.7	51.9	40.9	20.5
45 min	771	67.2	50.4	578.1	74.3	55.7	29.3	22.0
1 hr	605	53.0	53.0	604.6	58.2	58.3	23.0	23.0
2 hr	355	29.4	58.9	709.2	34.2	68.4	13.5	27.0
3 hr	252	20.7	62.0	756.0	24.3	72.9	9.6	28.7
4 hr	196	16.0	64.1	785.0	18.9	75.7	7.5	29.8
5 hr	161	13.1	65.7	804.6	15.5	77.6	6.1	30.6
8 hr	105	8.6	69.1	838.5	10.1	80.9	4.0	31.9
10 hr	85	7.1	70.6	850.3	8.2	82.0	3.2	32.3
20 hr	46	3.8	75.7	912.6	4.4	88.0	1.7	34.7

65-PC1750 performance data at 77°F, per 12V module

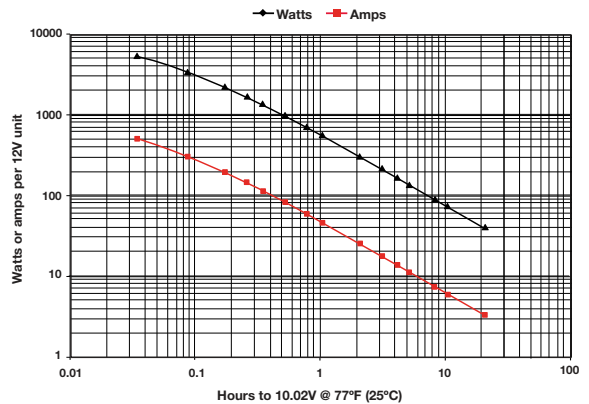

PC1800-FT performance data at 77°F, per 12V module

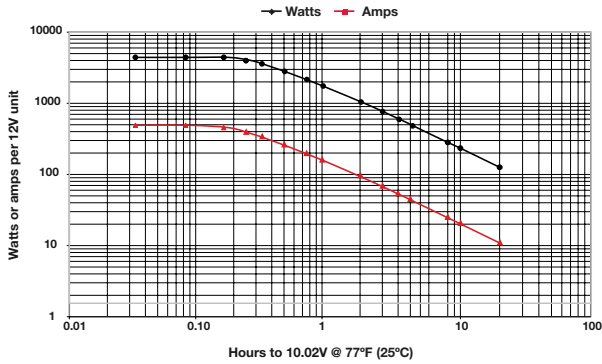

Time	Watts (W)	Amps (A)	Capacity (Ah)	Energy (Wh)	ENERGY AND POWER DENSITIES			
					W/liter	Wh/liter	W/kg	Wh/Kg
2 min	4422	491.4	16.4	147.4	199.6	6.7	73.7	2.5
5 min	4422	491.2	40.9	368.5	199.6	16.6	73.7	6.1
10 min	4422	454.7	75.8	737.0	199.6	33.3	73.7	12.3
15 min	3984	373.3	93.3	996.0	179.8	44.9	66.4	16.6
20 min	3384	312.7	104.2	1128.0	152.7	50.9	56.4	18.8
30 min	2610	238.3	119.2	1305.0	117.8	58.9	43.5	21.8
45 min	1968	177.8	133.4	1476.0	88.8	66.6	32.8	24.6
1 hr	1590	143.1	143.1	1590.0	71.8	71.8	26.5	26.5
2 hr	936	82.2	164.4	1872.0	42.2	84.5	15.6	31.2
3 hr	666	58.3	174.9	1998.0	30.1	90.2	11.1	33.3
4 hr	522	45.4	181.6	2088.0	23.6	94.2	8.7	34.8
5 hr	426	37.3	186.5	2130.0	19.2	96.1	7.1	35.5
8 hr	282	24.6	196.8	2256.0	12.7	101.8	4.7	37.6
10 hr	234	20.2	202.0	2340.0	10.6	105.6	3.9	39.0
20 hr	126	10.9	218.0	2520.0	5.7	113.7	2.1	42.0

31-PC2150 & 31M-PC2150 performance data at 77°F, per 12V module

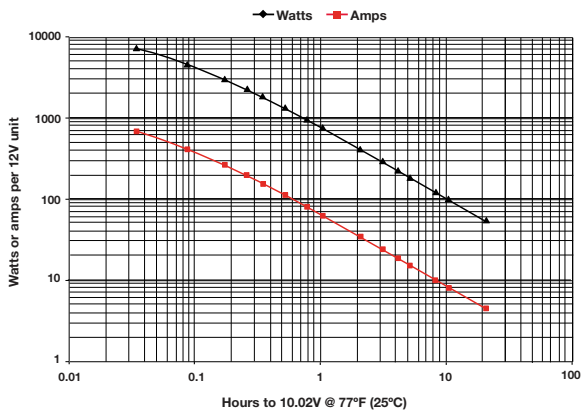

Time	Watts (W)	Amps (A)	Capacity (Ah)	Energy (Wh)	ENERGY AND POWER DENSITIES			
					W/liter	Wh/liter	W/kg	Wh/Kg
2 min	7025	678.5	22.4	231.8	515.3	17.0	199.0	6.6
5 min	4740	438.5	36.4	393.4	347.7	28.9	134.3	11.1
10 min	3176	285.9	47.7	530.4	233.0	38.9	90.0	15.0
15 min	2428	215.5	53.9	607.0	178.1	44.5	68.8	17.2
20 min	1980	174.1	58.0	659.2	145.2	48.4	56.1	18.7
30 min	1460	127.0	63.5	730.0	107.1	53.5	41.4	20.7
45 min	1059	91.2	68.4	793.9	77.6	58.2	30.0	22.5
1 hr	835	71.5	71.5	835.2	61.3	61.3	23.7	23.7
2 hr	461	39.0	78.0	922.2	33.8	67.7	13.1	26.1
3 hr	322	27.1	81.4	966.8	23.6	70.9	9.1	27.4
4 hr	249	20.9	83.8	996.8	18.3	73.1	7.1	28.2
5 hr	204	17.1	85.6	1020.0	15.0	74.8	5.8	28.9
8 hr	134	11.2	89.7	1070.4	9.8	78.5	3.8	30.3
10 hr	110	9.2	91.9	1095.9	8.0	80.4	3.1	31.0
20 hr	60	5.0	100.3	1191.9	4.4	87.4	1.7	33.8

PC2250 performance data at 77°F, per 12V module

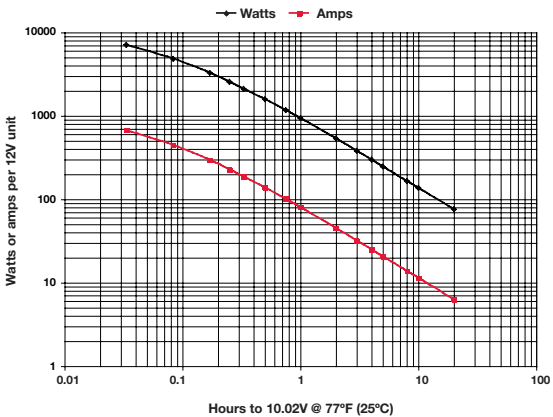

Time	Watts (W)	Amps (A)	Capacity (Ah)	Energy (Wh)	ENERGY AND POWER DENSITIES			
					W/liter	Wh/liter	W/kg	Wh/Kg
2 min	7090	671.6	22.4	236.1	1143.0	14.8	181.8	6.1
5 min	4820	443.8	37.0	401.5	301.2	25.1	123.6	10.3
10 min	3291	296.4	50.4	559.5	205.6	35.0	84.4	14.4
15 min	2553	227.1	56.8	638.3	159.5	39.9	65.5	16.4
20 min	2107	185.8	61.3	695.3	131.7	43.5	54.0	17.8
30 min	1583	137.9	69.0	791.5	98.9	49.5	40.6	20.3
45 min	1170	100.9	75.7	877.5	73.1	54.8	30.0	22.5
1 hr	937	80.2	80.2	937.0	58.6	58.6	24.0	24.0
2 hr	536	45.2	90.4	1072.0	33.5	67.0	13.7	27.5
3 hr	382	32.0	96.0	1146.0	23.9	71.6	9.8	29.4
4 hr	299	25.0	100.0	1196.0	18.7	74.7	7.7	30.7
5 hr	247	20.6	103.0	1235.0	15.4	77.2	6.3	31.7
8 hr	165	13.8	110.4	1320.0	10.3	82.5	4.2	33.9
10 hr	137	11.4	114.0	1370.0	8.6	85.6	3.5	35.1
20 hr	76	6.3	126.0	1520.0	4.75	95.0	2.0	39.0

CYCLE LIFE AND DEPTH OF DISCHARGE (DOD)

Applications in which the battery is frequently discharged and recharged are called cyclic. A complete cycle starts with a charged battery that is discharged and then brought back to a full charge. Battery life in these applications is stated as the number of cycles the battery will deliver before its capacity drops to 80% of its rated value. For example, suppose a battery is rated at 100 amp-hours (Ah) and has a published cycle life of 400. This means that the battery can be cycled 400 times before its delivered capacity drops to 80Ah.

Proper charging and DOD are the two key factors that determine how many cycles a battery will deliver before it reaches end of life. The DOD is simply the ratio of capacity extracted from the battery to its rated capacity expressed as a percentage. If a 100Ah battery delivers 65Ah and is then recharged, it is said to have delivered a 65% DOD cycle.

The relationship between DOD and cycle life for ODYSSEY batteries, excluding PC370, PC950 and PC1100, is shown in Figure 1. The lower the DOD the higher the number of cycles the battery will deliver before reaching end of life.

Figure 1

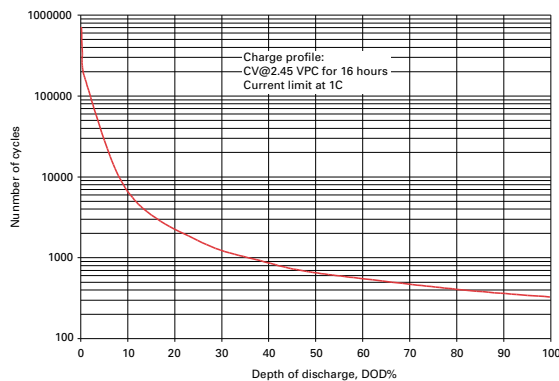

The true dual purpose design of ODYSSEY batteries is reflected in the cycle life results shown in the graph below. This graph is from an 80% DOD cycle test completed on two ODYSSEY 65-PC1750 battery samples. Both samples gave over 500 cycles before failing to give 80% capacity (this is classified as end of life.)

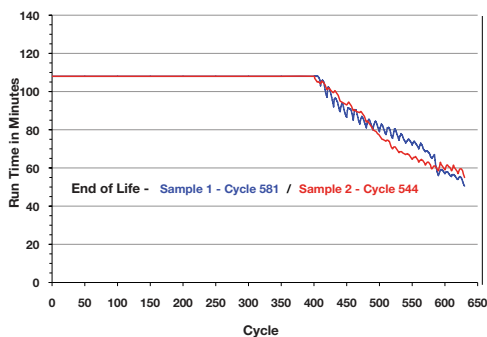

FLOAT LIFE

Float life refers to the life expectancy of a battery that is used primarily as a source of backup or emergency power. Emergency lighting, security alarm and Uninterruptible Power Systems (UPS) are good examples of batteries in float applications. In each of these applications the battery is discharged only if the main utility power is lost; otherwise the battery remains on continuous trickle charge (also called float charge).

Since ODYSSEY® batteries are dual purpose by design, they offer a long-life battery option in float applications. At room temperature (77°F or 25°C) these batteries have a design life of 10+ years in float applications; at end of life an ODYSSEY battery will still deliver 80% of its rated capacity.

ODYSSEY® BATTERY STORAGE AND DEEP DISCHARGE RECOVERY

For any rechargeable battery, storage and recharge are important criteria. This section provides some guidelines that will help you get the most from your ODYSSEY battery.

(A) How do I know the state of charge (SOC) of the battery?

Use Figure 2 to determine the SOC of the ODYSSEY battery, as long as the battery has not been charged or discharged for six or more hours. The only tool needed is a good quality digital voltmeter to measure its open circuit voltage (OCV)¹. The graph shows that a healthy, fully charged ODYSSEY battery will have an OCV of 12.84V or higher at 77°F (25°C).

Figure 2: Open circuit voltage and state of charge

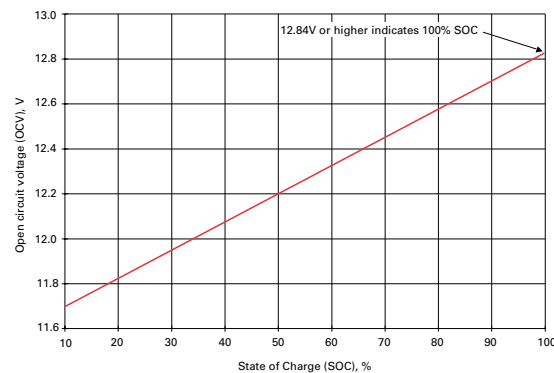

¹The OCV of a battery is the voltage measured between its positive and negative terminals without the battery connected to an external circuit (load). It is very important to take OCV reading only when the battery has been off charge for at least 6-8 hours, preferably overnight.

(B) How long can the battery be stored?

ODYSSEY batteries should be fully charged prior to storage. Fully charged ODYSSEY batteries can be stored for up to 24 months at 77°F (25°C). Battery voltage naturally decreases with time and with increased temperature. The battery voltage should be checked periodically. If the battery voltage drops to 12.0 volts (35% state of charge) it should be recharged immediately to avoid permanent battery damage. The following can be used as a rough approximation for the potential storage times at different temperatures.

Figure 3: ODYSSEY® battery storage time at temperatures

Storage Temperature (°F/°C)	Storage Time (Months)
41/5	48
59/15	36
77/25	24
95/35	12
113/45	6

(C) Can the battery recover from deep discharge conditions?

Yes, the ODYSSEY battery can recover from extremely deep discharges as the following test results demonstrate.

(1) German DIN standard test for overdischarge recovery

In this test, a PC925 was discharged over 20 hours (0.05C₁₀ rate)² to 10.20V. After the discharge² a 5Ω resistor was placed across the battery terminals and the battery kept in storage for 28 days.

At the end of the storage period, the battery was charged at 13.5V for only 48 hours. A second 0.05C₁₀ discharge yielded 97% of rated capacity, indicating that a low rate 48-hour charge after such a deep discharge was insufficient; however, the intent of the test is to determine if the battery is recoverable from extremely deep discharges using only a standby float charger. A standard automotive charger at 14.4V would have allowed the battery to recover greater than 97% of its capacity.

These test results prove that ODYSSEY batteries can recover from deep discharge conditions. Reinforcing this conclusion is the next test, which is even harsher than the DIN standard test, because in this test the battery was stored in a discharged state at a temperature of 122°F (50°C).

(2) High temperature discharged storage test

Two PC1200 samples were discharged in this test at the 1-hour rate to 9V per module, and then placed in storage at 122°F (50°C) in a *discharged condition* for 4 weeks.

At the end of 4 weeks, the two batteries were recharged using a constant voltage (CV) charge at 14.7V per battery. As Figure 4 below shows, both samples recovered from this extreme case of abusive storage.

Figure 4: Recovery from high temperature discharged storage

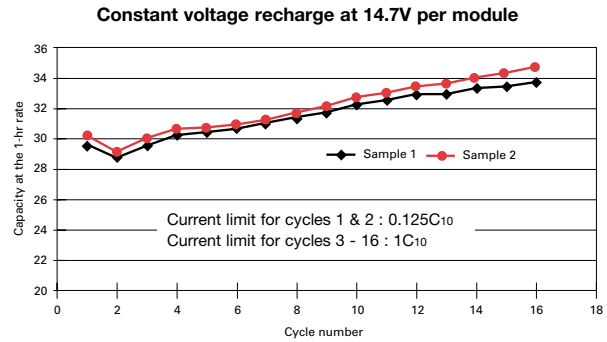

Extreme cold temperature performance

High discharge rate performance in extremely cold conditions is another area in which ODYSSEY® batteries excel. An example of this is shown in Figure 5. Even at -40°F (-40°C) the battery was able to support a 550A load for over 30 seconds before its terminal voltage dropped to 7.2V.

Figure 5: CCA test @ -40°F (-40°C) on 31-PC2150

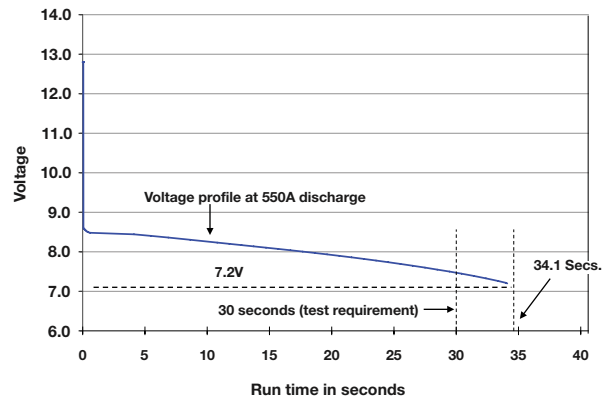

Since all ODYSSEY batteries are designed similarly, one can expect similar outstanding cold temperature performance from any of the other ODYSSEY batteries.

²The C10 rate of charge or discharge current in amperes is numerically equal to the 10 hour rated capacity of a battery in ampere-hours divided by 10. Thus, a 26Ah battery at the 10-hour rate, such as the PC925, would have a C10 rate of 2.6A.

PARASITIC LOADS

With the proliferation of more and more electronic equipment in cars, trucks, motorcycles and powersports equipment, the phenomenon of parasitic loads is becoming a serious problem.

Parasitic loads are small currents, typically of the order of a few milliamps (mA) that the battery has to deliver continuously. Retaining memories and operating security systems are common examples of parasitic drains on batteries in modern systems.

On the surface it would seem that such small loads would not be a factor in the overall scheme of things. However, since parasitic loads can be applied on a long-term basis (weeks or months is not uncommon), the cumulative amp-hours (Ah) extracted from the battery can be significant. For example, a 10mA draw on a motorcycle battery will discharge it by 0.24Ah per day. If left unchecked for 30 days, that small 10mA parasitic load will discharge a 20Ah battery by 7.2Ah – a 36% depth of discharge (DOD).

Regardless of the application, it is important to make sure your battery does not have a parasitic load; if there is a slow drain, connect the battery to a float (trickle) charger that puts out between 13.5V and 13.8V at the battery terminals. Physically disconnecting one of the battery cables is an alternate method to eliminate the drain.

SHOCK, IMPACT AND VIBRATION TESTING

(A) Caterpillar™ 100-hour vibration test

In this test, a fully charged battery was vibrated at 34 ± 1 Hz and 0.075" (1.9mm) total amplitude in a vertical direction, corresponding to an acceleration of 4.4g. The test was conducted for a total of 100 hours. The battery is considered to have passed the test if (a) it does not lose any electrolyte, (b) it is able to support a load test and (c) it does not leak when subjected to a pressure test.

The ODYSSEY battery successfully completed this arduous test.

(B) Shock and vibration test per IEC 61373, Sections 8-10

An independent test laboratory tested an ODYSSEY 31-PC2150 battery for compliance to IEC standard 61373, Category 1, Class B, and Sections 8 through 10. Section 8 calls for a functional random vibration test, Section 9 requires a long-life random vibration test and Section 10 is for a shock test. Table 2, in the next column summarizes the test results.

Table 2: Shock and vibration test results per IEC 61373

Test	Standard	Requirement	Result
Functional random vibration	IEC 61373, Section 8, Category 1, Class B	5-150Hz, 0.1g _{rms} vertical, 0.071g _{rms} longitudinal, 0.046g _{rms} transverse; 10 minutes in each axis	Compliant
Long-life random vibration	IEC 61373, Section 9, Category 1, Class B	5-150Hz, 0.8g _{rms} vertical, 0.56g _{rms} longitudinal, 0.36g _{rms} transverse; 5 hours in each axis	Compliant
Shock	IEC 61373, Section 10, Category 1, Class B	30msec. pulses in each axis (3 positive, 3 negative); 3.06g _{peak} vertical, 5.1g _{peak} longitudinal, 3.06g _{peak} transverse	Compliant

CHARGING ODYSSEY® BATTERIES

Charging is a key factor in the proper use of a rechargeable battery. Inadequate or improper charging is a common cause of premature failure of rechargeable lead acid batteries. To properly charge your premium ODYSSEY® battery, EnerSys® has developed a special charge algorithm. It is designed to rapidly and safely charge these batteries. Called the IUU profile (a constant current mode followed by two stages of constant voltage charge), Figure 6 shows it in a graphical format. No manual intervention is necessary with chargers having this profile.

Figure 6: Recommended three-step charge profile

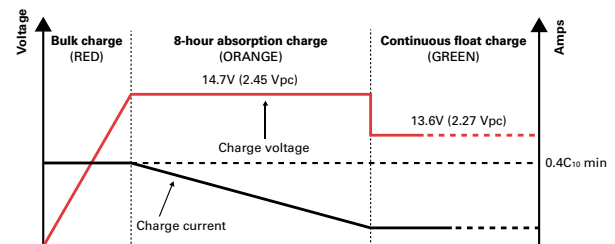

NOTES:

1. Charger LED stays RED in bulk charge phase (DO NOT TAKE BATTERY OFF CHARGE)
2. LED changes to ORANGE in absorption charge phase (BATTERY AT 80% STATE OF CHARGE)
3. LED changes to GREEN in float charge phase (BATTERY FULLY CHARGED)
4. Charge voltage is temperature compensated at $\pm 24\text{mV}$ per battery per $^{\circ}\text{C}$ variation from 25°C

If the charger has a timer, then it can switch from absorption mode to float mode when the current drops to $0.001C_{10}$ amps. If the current fails to drop to $0.001C_{10}$ amps, then the timer will force the transition to a float charge after no more than 8 hours. As an example, for a PC1200 battery, the threshold current should be 4mA. Another option is to let the battery stay in the absorption phase (14.7V or 2.45 VPC) for a fixed time, such as 6-8 hours, then switch to the continuous float charge.

Table 3 shows the minimum charge currents for the full range of ODYSSEY batteries when they are used in deep cycling application. When using a charger with the IUU profile, we suggest the following ratings for your ODYSSEY battery. *Note the charger current in the bulk charge mode must be 0.4C₁₀ or more.* A list of chargers approved by EnerSys for use with ODYSSEY batteries is available at www.odysseybattery.com under FAQs.

Table 3: Battery size and minimum three-step charger current

Charger rating, amps	Recommended ODYSSEY® Battery Model*
6A	PC310 / PC370 / PC535 / PC545 / PC625 / PC680
10A	PC925 or smaller battery
15A	PC1200 or smaller battery
25A	PC1500 or smaller battery
25A	PC1700 or smaller battery
40A	PC2150 or smaller battery
50A	PC2250 or smaller battery

* for PC1800, consult EnerSys Technical Department

Small, portable automotive and powersport chargers may also be used to charge your ODYSSEY battery. These chargers are generally designed to bring a discharged battery to a state of charge (SOC) that is high enough to crank an engine. Once the engine is successfully cranked, its alternator should fully charge the battery. It is important to keep in mind the design limitations of these small chargers when using them.

Another class of chargers is designed specifically to maintain a battery in a high SOC. These chargers, normally in the 3/4 amp to 1 1/2 amp range, are not big enough to charge a deeply discharged ODYSSEY® battery. They must only be used either to continuously compensate for parasitic losses or to maintain a trickle charge on a stored battery, as long as the correct voltages are applied. It is very important, therefore, to ensure that the ODYSSEY battery is fully charged before this type of charger is connected to it.

Effect of undercharge in cycling applications

Proper and adequate charging is necessary to ensure that ODYSSEY batteries deliver their full design life. Generally speaking, a full recharge requires about 5% more amp-hours (Ah) must be put back in than was taken out. In other words, for each amp-hour extracted from the battery, about 1.05Ah must be put back to complete the recharge.

Cycling tests conducted on an ODYSSEY PC545 battery demonstrated the impact raising the charge voltage from 14.2V to 14.7V has on the cycle life of the battery. The results are shown in the graph at right.

Samples 1 and 2 were charged at 14.2V while Samples 3 and 4 were charged at 14.7V. All batteries were discharged

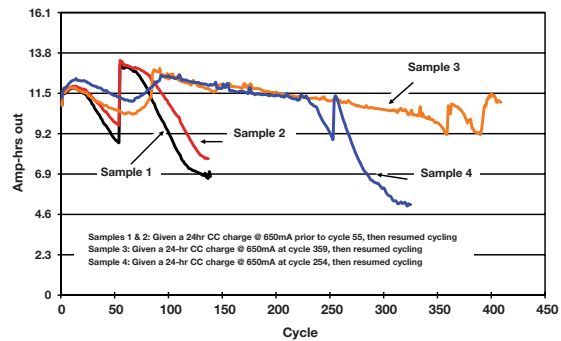

at 2.3A until the terminal voltage dropped to 10.02V and charged for 16 hours. In this particular test, a capacity of 11.5Ah corresponds to 100% capacity and 9.2Ah is 80% of rated capacity and the battery is considered to have reached end of life at that point.

The message to be taken from this graph is clear – in deep cycling applications it is important to have the charge voltage set at 14.4 – 15.0V. A nominal setting of 14.7V is a good choice, as shown by the test results.

(A) Selecting the right charger for your battery

Qualifying portable automotive and powersport chargers for your ODYSSEY battery is a simple two-step process.

Step 1 Charger output voltage

Determining the charger output voltage is the most important step in the charger qualification process. *If the voltage output from the charger is less than 14.2V or more than 15V for a 12V battery, then do not use the charger.* For 24V battery systems, the charger output voltage should be between 28.4V and 30V. If the charger output voltage falls within these voltage limits when the battery approaches a fully charged state, proceed to Step 2, otherwise pick another charger.

Step 2 Charger type - automatic or manual

The two broad types of small, portable chargers available today are classified as either automatic or manual. Automatic chargers can be further classified as those that charge the battery up to a certain voltage and then shut off and those that charge the battery up to a certain voltage and then switch to a lower float (trickle) voltage.

An example of the first type of automatic charger is one that charges a battery up to 14.7V, then immediately shuts off. An example of the second type of automatic charger would bring the battery up to 14.7V, then switches to a float (trickle) voltage of 13.6V; it will stay at that level indefinitely. The second type of automatic charger is preferred, because the first type of charger will undercharge the battery.

A manual charger typically puts out either a single voltage or single current level continuously and must be switched off manually to prevent battery overcharge. *Should you choose to use a manual charger with your ODYSSEY battery, do not exceed charge times suggested in Table 5 on the next page. It is extremely important to ensure the charge voltage does not exceed 15V.*

(B) Selecting battery type on your charger

Although it is not possible to cover every type of battery charger available today, this section gives the ODYSSEY battery user some general charger usage guidelines to follow, after the charger has been qualified for use with this battery.

In general, do not use either the gel cell or maintenance free setting, if provided on your charger. Choose the deep cycle or AGM option, should there be one on your charger. Table 5 below gives suggested charge times based on charger currents. As previously indicated, deep cycling applications require a minimum 0.4C₁₀ current available from the charger so the values shown in Table 5 do not apply to all products in all applications. To achieve maximum life from your ODYSSEY battery after completing the charge time in Table 5, we recommend that you switch your charger to the trickle charge position and leave the battery connected to the charger for an additional 6-8 hours. The trickle charge voltage should be 13.5V to 13.8V.

Table 5: Suggested charge times (excludes cycling applications)

ODYSSEY® Battery Model	Charge time for 100% discharged battery	
	10-amp charger	20-amp charger
PC310	1.28 hours	40 minutes
PC370 & PC535	2.25 hours	1.25 hours
PC545	2 hours	1 hour
PC625	3 hours	1.5 hours
PC680	2.7 hours	1.5 hours
PC925	4.5 hours	2.25 hours
PC950	5.25 hours	3 hours
PC1100	7 hours	3.75 hours
PC1200	6.75 hours	3.5 hours
75-PC1230 & 75/86-PC1230	9 hours	4.5 hours
25-PC1400 & 35-PC1400	10.5 hours	5.25 hours
34-PC1500, 34R-PC1500, 34M-PC1500, 34/78-PC1500 & 78-PC1500	11 hours	5.5 hours
PC1700	11 hours	5.5 hours
PC1220 & 65-PC1750	11 hours	5.5 hours
PC1800-FT	Not Recommended	17 hours
PC1350, 31-PC2150 & 31M-PC2150	16 hours	8 hours
PC2250	20 hours	10 hours

The charge times recommended in Table 5 assume that the ODYSSEY® battery is fully discharged and these charge times will only achieve about a 80% state of charge. For partially discharged batteries, the charge times should be appropriately reduced. The graph in Figure 2, showing OCV and SOC, must be used to determine the battery's SOC. The battery should be trickle charged after high rate charging, regardless of its initial SOC.

Temperature compensation

Proper charging of all Valve Regulated Lead Acid (VRLA) batteries requires temperature compensation of the charge voltage – the higher the ambient temperature the lower the charge voltage. This is particularly true in float applications in which the batteries can stay on trickle charge for weeks or months at a time.

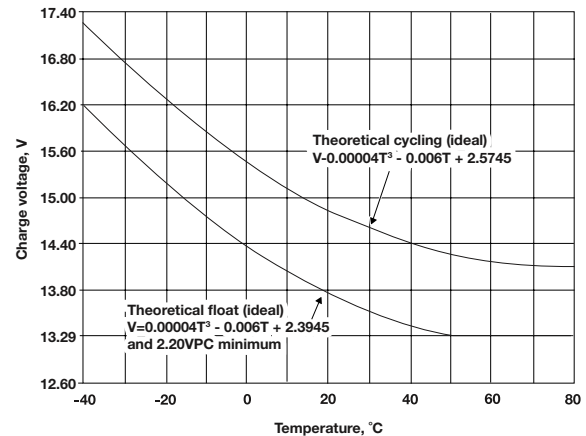

The temperature compensation graphs for ODYSSEY batteries in float and cyclic applications are shown for ambient (battery) temperatures ranging from -40°F (-40°C) to 176°F (80°C). The compensation coefficient is approximately

+/-24mV per 12V battery per °C variation from 77°F (25°C). Since the charge voltage and ambient (battery) temperature are inversely related, the voltage must be reduced as the temperature rises; conversely, the charge voltage must be increased when the temperature drops.

Note, however, that the charge voltage should not be dropped below 13.2V as that will cause the battery grids to corrode faster, thereby shortening the battery life.

RAPID CHARGING OF ODYSSEY® BATTERIES

All ODYSSEY batteries can be quickly charged. Figure 7 on the next page shows their exceptional fast charge characteristics at a constant 14.7V for three levels of inrush current. These current levels are similar to the output currents of modern automotive alternators. Table 6 and Figure 7 show the capacity returned as a function of the magnitude of the inrush³ current.

Standard internal combustion engine alternators with an output voltage of 14.2V can also charge these batteries. The inrush current does not need to be limited under constant voltage charge. However, because the typical alternator voltage is only 14.2V instead of 14.7V, the charge times will be longer than those shown in Table 5.

³ Inrush is defined in terms of the rated capacity (C₁₀) of the battery. A 0.8C₁₀ inrush on a 100Ah battery is 80A.

Table 6: Fast charge capability

Capacity returned	Inrush current magnitude		
	0.8C ₁₀	1.6C ₁₀	3.1C ₁₀
60%	44 min.	20 min.	10 min.
80%	60 min.	28 min.	14 min.
100%	90 min.	50 min.	30 min.

Table 6 shows that with a 0.8C₁₀ inrush current, a 100% discharged battery can have 80% of its capacity returned in 57 minutes; doubling the inrush to 1.6C₁₀ cuts the time taken to reach 80% capacity to only 28 minutes.

Figure 7: Quick charging ODYSSEY® batteries

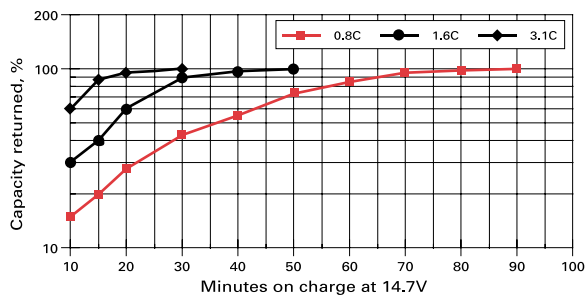

LOAD TEST PROCEDURE

This procedure should help determine whether the battery returned by the customer has reached its end of life or simply needs a full recharge. Depending on the time available one may choose to perform either the longer load test (Step 4) or the shorter ½CCA load test (Step 5).

The ½CCA test is quicker but less reliable than the longer test. This is also the test that is performed when a battery is taken to an auto store for testing.

1. Measure the open circuit voltage (OCV) of the battery. Proceed to Step 4 or Step 5 if the OCV is equal to or more than 12.80V; if not go to Step 2.
2. Charge the battery until the device indicates the charge is complete.
3. Unplug the charger and disconnect the battery from the charger. Let the battery rest of at least 10-12 hours and measure the OCV. If it is equal to or more than 12.80V proceed to the next step; otherwise reject the battery.
4. Long Test: Discharge the battery using a resistor or other suitable load until the voltage drops to 10.00V and record the time taken to reach this voltage. Let the battery rest for an hour and repeat Steps 1 through 4. If the time taken by the battery to drop to 10.00V is longer in the second discharge than in the first discharge, the battery may be returned to service after a full recharge; if not the battery should be rejected as having reached end of life.

5. ½CCA Test: Battery OCV must be at least 12.60V to proceed with this test. Connect the load tester cables and the voltage leads of a separate digital voltmeter (if the tester does not have a built-in digital voltmeter) to the battery terminals.

6. Adjust the tester load current to load the battery to half its rated CCA and apply the load for 15 seconds. Table 7 shows the ½CCA values for all ODYSSEY® battery models. Use Table 8 to adjust the battery end of test voltage temperature.

Table 7

ODYSSEY® Battery Model	½CCA Test Value (A)	ODYSSEY® Battery Model	½CCA Test Value (A)	ODYSSEY® Battery Model	½CCA Test Value (A)
PC310	50	PC1100	250	PC1700	405
PC370	100	PC1200	270	PC1750	475
PC535	100	PC1220	340	PC1800	650
PC545	75	PC1230	380	PC2150	575
PC625	100	PC1350	385	PC2250	613
PC680	85	PC1400	425		
PC925	165	PC1500	425		
PC950	200				

Table 8

Temperature	End of Test Voltage
70°F	9.60V
60°F	9.50V
50°F	9.40V
40°F	9.30V
30°F	9.10V
20°F	8.90V
10°F	8.70V
0°F	8.50V

7. At the end of 15 seconds note the battery voltage on the voltmeter and discontinue the test. If the temperature is 70°F (21°C) or warmer the battery voltage should be at or above 9.60V. If so the battery can be returned to service; if below 9.60V the battery should be rejected.

ODYSSEY® BATTERIES IN NO-IDLE APPLICATIONS

Since these batteries are dual purpose in nature they can be used for both engine starting and deep cycling applications. This makes them particularly well suited for fleets such as police vehicles that would like to power their computers and communications equipment without having to idle their engines. Auxiliary power units (APU) on trucks provide another example of a no-idling application.

All of these require energy sources to power loads such as computers and refrigerators with the engines shut off to reduce their carbon footprints and lower gas consumption.

As discussed in a previous section, properly charged ODYSSEY batteries are capable of delivering as many as 400 cycles to a 80% depth of discharge (DOD). A shallower discharge will yield higher cycles, as noted in the cycle life vs. DOD graph shown earlier. This is the reason why ODYSSEY batteries are becoming increasingly popular in APU and police fleet applications that require batteries to have both high cycling and excellent engine cranking capabilities in the same package.

PARALLEL CONNECTIONS

It is common to have batteries connected in parallel to achieve a desired amp-hour capacity. This is done by connecting all the positives to each other and all the negatives to each other.

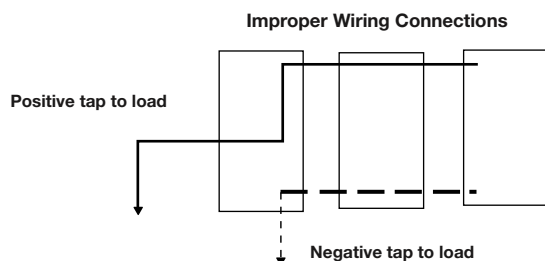
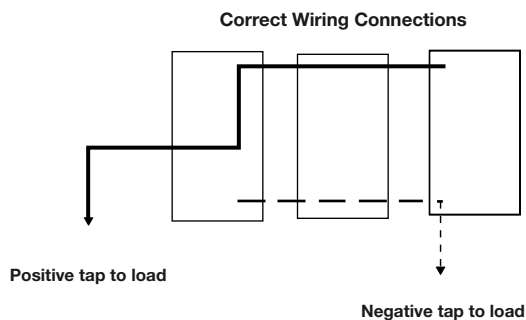

Typically the positive and negative leads to the load are taken from the same battery; usually the leads from the first battery are used. This is not a good practice. Instead, a better technique to connect the load is to take the positive lead from one end of the pack (the first or last battery) and the negative lead from the other end of the pack. The two methods are illustrated above. Solid lines and arrows indicate positive terminals and leads; broken lines and arrows indicate negative terminals and leads.

In both illustrations, the positive leads are connected to each other; similarly the negative leads are connected to each other. The only difference is that in the first illustration the positive and negative leads to the load come from the first and last batteries. In the second case, both leads to the load are tapped from the same battery.

The first schematic is recommended whenever batteries are hooked up in parallel to increase battery capacity. With this wiring, all batteries are forced to share both charge and discharge currents. In contrast, a closer inspection of the second schematic shows that it is possible for only the battery whose terminals are tapped to support the load. Implementing the first schematic eliminates this possibility and is therefore a better one.

VENTILATION

Valve Regulated Lead Acid (VRLA) batteries like the ODYSSEY® battery depend on the internal recombination of the gases for proper operation. This is also why these batteries do not require periodic addition of water.

The high recombination efficiency of ODYSSEY batteries make them safe for installation in human environments. It is not uncommon to see these batteries in aircraft, hospital operating rooms and computer rooms. The only requirement is that these batteries must not be installed in a sealed or gastight enclosure; however, local regulations with respect to ventilation requirements must be followed.

CONCLUDING REMARKS

We believe that there is no other sealed-lead acid battery currently available commercially that can match the ODYSSEY battery for sheer performance and reliability. We hope that the preceding material will help the reader arrive at the same conclusion.

FREQUENTLY ASKED SLI BATTERY QUESTIONS

What is the CCA rating?

The cold cranking ampere (CCA) rating refers to the number of amperes a battery can deliver for 30 seconds at a temperature of 0°F (-18°C) before the voltage drops to 1.20 volts per cell, or 7.20 volts for a 12V battery. A 12V battery that has a rating of 550 CCA means that the battery will provide 550 amps for 30 seconds at 0°F (-18°C) before the voltage falls to 7.20V.

What is the MCA rating?

The marine cranking ampere (MCA) rating refers to the number of amperes a battery can deliver for 30 seconds at a temperature of 32°F (0°C) until the battery voltage drops to 7.20 volts for a 12V battery. A 12V battery that has a MCA rating of 725 MCA means that the battery will give 725 amperes for 30 seconds at 32°F (0°C) before the voltage falls to 7.20V.

The MCA is sometimes called the cranking amperes or CA.

What is a HCA rating?

The abbreviation HCA stands for hot cranking amps. It is the same as MCA, CA or CCA, except that the temperature at which the test is conducted is 80°F (26.7°C).

What is the PHCA rating?

Unlike CCA and MCA the pulse hot cranking amp (PHCA) rating does not have an "official" definition; however, we believe that for true SLI purposes, a 30-second discharge is unrealistic. The PHCA, a short duration (about 3-5 seconds) high rate discharge, is more realistic. Because the discharge is for such a short time, it is more like a pulse.

Are these gel cells?

No, the ODYSSEY® battery is NOT a gel cell. It is an absorbed electrolyte type battery, meaning there is no free acid inside the battery; all the acid is kept absorbed in the glass mat separators. These separators serve to keep the positive and negative plates apart.

What is the difference between gel cell and AGM?

The key difference between the gel cell and the absorbed glass mat (AGM) is that in the AGM cell all the electrolyte is in the separator, whereas in the gel cell the acid is in the cells in a gel form. If the ODYSSEY battery were to split open, there would be no acid spillage! That is why we call the ODYSSEY battery a Drycell battery.

What is the Ah rating?

The ampere-hour (Ah) rating defines the capacity of a battery. A battery rated at 100Ah at the 10-hour rate of discharge will deliver 10A for 10 hours before the terminal voltage drops to a standard value such as 10.02 volts for a 12V battery. The PC1200 battery, rated at 40Ah will deliver 4A for 10 hours.

What is reserve capacity rating?

The reserve capacity of a battery is the number of minutes it can support a 25-ampere load at 80°F (27°C) before its voltage drops to 10.50 volts for a 12V battery. A 12V battery with a reserve capacity rating of 100 will deliver 25 amps for 100 minutes at 80°F before its voltage drops to 10.5V.

Is the ODYSSEY® battery a dry battery?

Because the ODYSSEY® battery has no free acid inside, it is exempted from the requirements of 49 CFR § 173.159 of the US Department of Transportation (USDOT). The battery also enjoys a “nonspillable” classification and falls under the International Air Transport Association (IATA) “unrestricted” air shipment category. These batteries may be shipped completely worry-free. Supporting documentation is available.

What is impedance?

The impedance of a battery is a measure of how easily it can be discharged. The lower the impedance the easier it is to discharge the battery. The impedance of the ODYSSEY battery is considerably less than that of a conventional SLI battery, so its high rate discharge capability is significantly higher than that of a conventional SLI battery.

What is the short-circuit current of these batteries?

As mentioned before, this battery has very low impedance, meaning that the short circuit current is very high. For a PC925 battery, the short circuit current can be as high as 2,500 amperes.

Do I ruin the battery if I accidentally drop it?

Not necessarily, but it is possible to damage the internal connections sufficiently to damage the battery.

Does mishandling the battery void the warranty?

Our warranty applies only to manufacturing defects and workmanship issues; the policy does not cover damages suffered due to product mishandling.

What is so special about thin plate pure lead technology? Is it a new technology?

The answer lies in the very high purity (99.99%) of our raw lead materials, making our product very special. The technology is not new; the sealed lead recombinant technology was invented and patented by us back in 1973.

Why don't you have to winterize your batteries? What's so special about them?

In general, winterizing refers to a special maintenance procedure conducted on an automotive engine to ensure its reliability during the winter season. The procedure essentially checks the engine's charging system; in addition, the battery is load tested according to a specific method defined by the Battery Council International (BCI). Although ODYSSEY batteries do not specifically require this test to be conducted on them, the final decision whether or not to conduct this test is left to the user's discretion.

Are these Ni-Cd batteries? Why doesn't somebody make these in Ni-Cd? Wouldn't they charge faster as a Ni-Cd?

No, the ODYSSEY battery is NOT a Ni-Cd battery. It is a valve regulated lead acid (VRLA) battery. In general, Ni-Cd batteries are much more expensive to manufacture and recycle, so they are less cost effective than a lead acid product.

A Ni-Cd battery would charge faster than a conventional lead acid battery; however, the ODYSSEY battery is NOT a conventional battery and its charge characteristics are somewhat similar to nickel cadmium batteries. In fact, with a powerful enough charger, it is possible to bring ODYSSEY batteries to better than 95% state of charge in less than 20 minutes! That is very comparable to the fast charge capabilities of a nickel cadmium product.

About EnerSys®

EnerSys® is a global leader in stored energy solutions for automotive, military, and industrial applications. With manufacturing facilities in 18 countries, sales and service locations throughout the world, and over 100 years of battery experience, EnerSys is a powerful partner for automotive service and parts providers.

EnerSys

2366 Bernville Road
Reading, PA 19605
Tel: +1-610-208-1991
+1-800-538-3627

EnerSys EMEA

EH Europe GmbH
Löwenstrasse 32
8001 Zürich, Switzerland
Tel: +41 (0) 44 215 74 10

EnerSys Asia

152 Beach Road
Gateway East Building #11-03
Singapore 189721
Tel: +65 6508 1780

www.odysseybattery.com



© 2014 EnerSys. All rights reserved.

Trademarks and logos are the property of EnerSys and its affiliates, except Caterpillar™, which is not the property of EnerSys.

Publication No: US-ODY-TM-002 – December 2014 Subject to revisions without prior notice. E.&O.E.