

2020 Jeep Gladiator 3.6L Intercooled System **Installation Guide**



The **ULTIMATE** Power Adder™

Accessible Technologies, Inc.
14801 W. 114th Terrace
Lenexa, KS 66215
Phone: 913.338.2886
Fax: 913.338.2879
techserv@procharger.com

All rights reserved. Accessible Technologies Inc. hereby grants permission to use and reproduce this document for personal use, provided that all copyright information be retained. Reproduction of this document for unauthorized commercial use is strictly prohibited.

Information in this document is subject to change without notice.

ProCharger is a registered trademark and The Intercooled Supercharging Experts![™] and Designed to Blow Away the Competition[™] are trademarks of Accessible Technologies, Inc. and may not be used without express permission.

You should also have the following gauges available to properly check the finished installation and monitor your vehicle's performance (especially for testing):

- Manifold Boost Pressure Gauge
- Fuel Pressure Gauge
- Wide Band Oxygen Sensor and Gauge

Gauges should be of a type that can be read from the cockpit while performing a wide-open throttle road test. Cockpit or hood-mounted gauges are preferable. In order to obtain usable readings, the gauges should measure pressure at the intake manifold and fuel rail. IF VEHICLE DOES NOT MAINTAIN PROPER FUEL PRESSURE (50-65 PSI), DECREASE THROTTLE APPLICATION IMMEDIATELY. In some cases, extra vehicle modifications can strain the stock fuel pump. If your vehicle has difficulty retaining adequate fuel pressure, contact ATI ProCharger about the availability of an upgraded fuel system.

The engine on which the ProCharger[®] is to be installed should retain the factory compression ratio. If it has been modified in any way, please consult ProCharger staff before proceeding with the installation. This supercharger system is intended for use on STOCK, strong, well-maintained engines/transmissions. Installation on a worn or troublesome powertrain should be reconsidered. ATI PROCHARGER WILL NOT BE HELD RESPONSIBLE FOR DAMAGE TO A VEHICLE'S POWERTRAIN. ATI ProCharger is not responsible for ECM tuning/programming on non-stock vehicles. ATI PROCHARGER recommends verifying that your vehicle has current ECM updates from the vehicle manufacturer before installation.

For best performance and reliability, always use premium grade fuel (91 octane or higher) and listen closely for signs of detonation, which might sound like ball bearings rolling around in a tin can. IF DETONATION SHOULD OCCUR, OR IF YOU ARE UNSURE WHETHER WHAT YOU'RE HEARING IS DETONATION, DECREASE THROTTLE APPLICATION IMMEDIATELY and please consult ATI ProCharger staff. Detonation should not be an issue with a properly installed intercooled supercharger system, though OEM factory-shipped engine and parts inconsistencies are possible on any vehicle.

INTRODUCTION

Congratulations on purchasing your ProCharger® 2020 Jeep Gladiator Intercooled System. Read this entire manual before you attempt to install your ProCharger kit. It is imperative that you follow all of the instructions in the order they appear in this installation guide. If you have any questions regarding any aspect of this installation, call us at (913) 338-2886.

For best results, we recommend reviewing the installation instructions beforehand, and following the installation instructions closely and in sequence. A detailed packing list has been provided to assist you in identifying the components of your ProCharger system.

 **Tech Tip:** *Installing spark plugs that are one heat ranger colder than stock and gapping your plugs to .035" is recommended.*

 **Warning:** *Read and understand all safety precautions in this manual before installation. Failure to comply with instructions in this manual could result in personal injury, property damage, and/or voiding your warranty.*

Required Tools and Supplies

- Open End Wrench Set (standard & metric)
- 3/8" & 1/2" Socket Sets (standard & metric)
- 3/8" Hex Bit Set (standard & metric)
- 8mm nut driver
- Torx bit set
- 1/2" Extension
- 1/2" Breaker Bar
- Plier Set
- WD-40

 **Warning:** *Your supercharged vehicle must always be run on 91 octane or better gas. The best way to insure this is to run the tank near empty (below 1/4) and fill with 91 octane for several tanks prior to installing the supercharger.*

TABLE OF CONTENTS

Introduction i

Table of Contents.....ii

Getting Started..... 1

Fuel Injectors 6

Alternator Relocation 11

Bump Stop..... 13

Main Bracket Assembly..... 14

ProCharger Head Unit 18

Alternator Wiring..... 20

Intercooler and Tubing..... 21

Surge System 30

PCV..... 32

Air Inlet..... 35

Final Assembly 36

Operation and Maintenance 39

Limited Warranty 41

TUNING IS REQUIRED WHEN INSTALLING YOUR PROCHARGER SYSTEM. IF A COMPLETE SYSTEM WAS PURCHASED. SEE SUPPLEMENTAL TUNING GUIDE. IF A TUNER KIT WAS PURCHASED. TUNING WILL HAVE TO BE PERFORMED BEFORE OPERATING THE VEHICLE.

GETTING STARTED



Completion of this section will configure the vehicle for system installation:

- (A) Engine Cover
- (B) Factory Air Filter Box
- (C) Factory Air Inlet
- (D) Battery

! *Read and understand all safety precautions in this manual before installation. Failure to comply with instructions in this manual could result in personal injury, property damage, and/or voiding your warranty.*

Getting Started

- 1 Use an 10mm to disconnect the negative battery terminal.

✓ **Tech Tip:** If equipped use a 13mm to remove the secondary battery negative cable from the main battery cable. If the cable is not removed the vehicle will still have power.



Battery Connections

- 2 Remove the (2) bolts on the front of the engine cover using either a T30 or 10mm. Pull forward on the engine cover to remove it.

- 3 Use an 8mm to loosen the hose clamp connecting the air filter box to the inlet tube and the clamp connecting the inlet tube to the throttle body.

- 4 Unplug the PCV line from the inlet by pressing the grey tab and pulling out on the connector



Battery Connections

- 5 Use a 10mm to remove the (2) screws holding the inlet tube to the cooling fan.

- 6 Unplug the intake air temperature (IAT) sensor from the inlet tube by pushing in the clip and pulling out. Remove the (2) push pins holding the wiring harness and (1) push pin holding the coolant line.



Remove Inlet And Cover Screws

- 7 Remove the air inlet tube.
- 8 With a 10mm remove the bolt securing the airbox to the fender. Pull up on the airbox to remove it from the vehicle.



Remove Bolt

- 9 Remove the (2) bolts retaining the air pump to the alternator bracket with a 13mm. Set the pump off to the side. Keep the bolts for use later.



Remove Air Pump Bolts

- 10 Insert a 1/2" breaker bar and extension into the square slot on the tensioner as shown. Push the breaker bar towards the driver's side. A constant, steady pressure on the breaker bar will slowly compress the tensioner. Once the tensioner is fully compressed, remove the belt from the idler pulley.



Compress the Tensioner and Remove Belt

Getting Started

- 11 Unplug the alternator wiring connector. Make certain the battery is disconnected. Remove the plastic cover over the alternator power wire connection. Use a 13mm to remove the nut holding the power wire to the alternator.



Alternator Connections

- 12 Use a 13mm to remove the (2) lower alternator bolts.
- 13 Use a 15mm to remove the (2) upper alternator bolts and remove the alternator.

✓ **Tech Tip:** A breaker bar may need to be used on the 15mm bolts, They may be extremely tight.



Alternator Bolts

- 14 Use a 16mm to remove the upper alternator bracket bolt and a 13mm to remove the lower alternator bracket bolt (the lower bolt will need to be saved for use later). Remove the bracket.

- 15 Remove the factory belt.



Alternator Bracket Bolts

- 16 Remove the (6) plastic push clips holding the front grille to the radiator core support.



Grille Clips

- 17 Pull out on the bottom of the grille to release the clips. Remove the grille.



Alternator Bolts

FUEL INJECTORS

- 1 Unplug the harness at the throttle-body, along with the plastic clip securing the harness to the throttle-body. Unplug the purge line tube from behind the throttle-body.

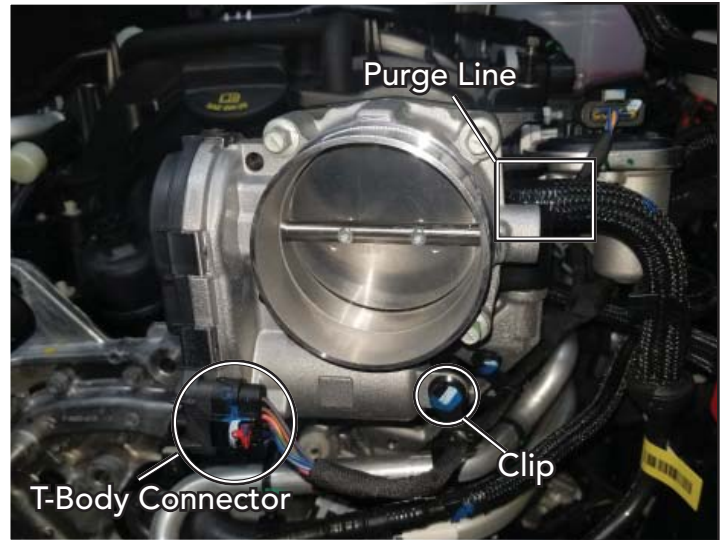

Throttle Body Connections

- 2 Using a 10mm remove the (2) bolts securing the engine cover bracket to the intake manifold. Set a-side.



Engine Cover Mount

- 3 Unhook the PCV line from the top of the intake and disconnect the clip at the rear of the intake. Unplug the rubber line at the front of the intake and unhook the valve from the back of the intake. Remove (2) bolts behind throttle body with a 10mm.



Unhook Lines

- 4 Unclip the lines on the passenger side of the intake.



Unclip Lines

- 5 Unplug the MAP sensor at the back of the intake on the drivers side.



MAP Sensor

- 6 Unhook the harness on the valve on the drivers side of the intake. Use a 10mm to remove the (2) bolts holding it to the tube and (3) nuts securing it to the intake. Carefully remove the valve from the intake being sure not to damage or loose the gaskets.



Remove Bolts

Fuel Injectors

- 7 Use a 10mm to remove the (2) nuts and (1) bolt shown to the right securing the metal tube and lower bracket. Unhook the (2) orange push connectors holding the wiring harness to the intake.



Remove Hardware And Clip

- 8 Using a T-45 torx socket remove the bracket bolt located on the side of the engine block. The bolt is located just above the back of the A/C compressor.

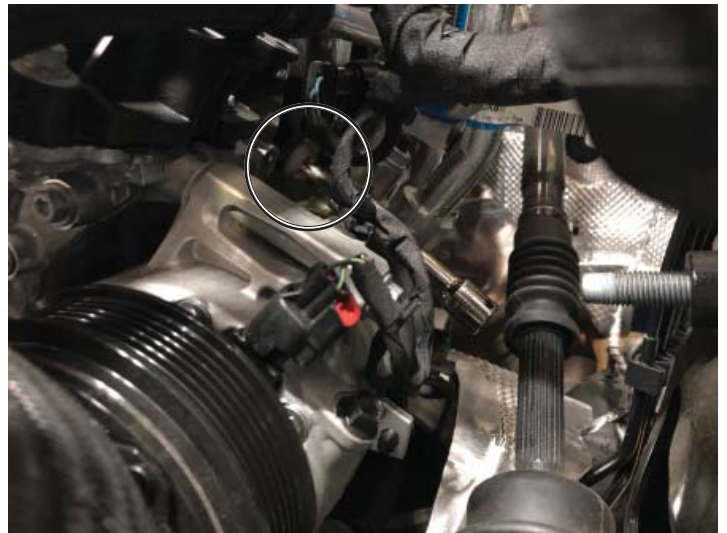

Remove Torx Bolt

- 9 Using an 8mm loosen the (8) bolts securing the upper intake to the lower.
- 10 Pull the metal tube away from the stud on the drivers side and carefully lift the upper intake off of the lower intake (there are several studs on the drivers side that the intake, which will take some finesse to get around when pulling the intake up).



Remove Bolts (7 of 8 Shown)

- 11 Remove the foam pad from on top of the driver's side valve cover.
- 12 Cover the lower intake manifold runners with tape or rags to prevent debris from falling into the runners.
- 13 Unplug all of the injector and coil connectors.
- 14 Use a 10mm to remove the coil bolts and remove the coils.
- 15 Use a 5/8 spark plug socket to remove the spark plugs. Gap the spark plugs to .035".

! **Note:** If installing new spark plugs, use one heat range colder than the stock plugs. NGK 1422 plugs are recommended.

- 16 Apply anti-seize to the spark plug threads and reinstall.



Intake Manifold Removed

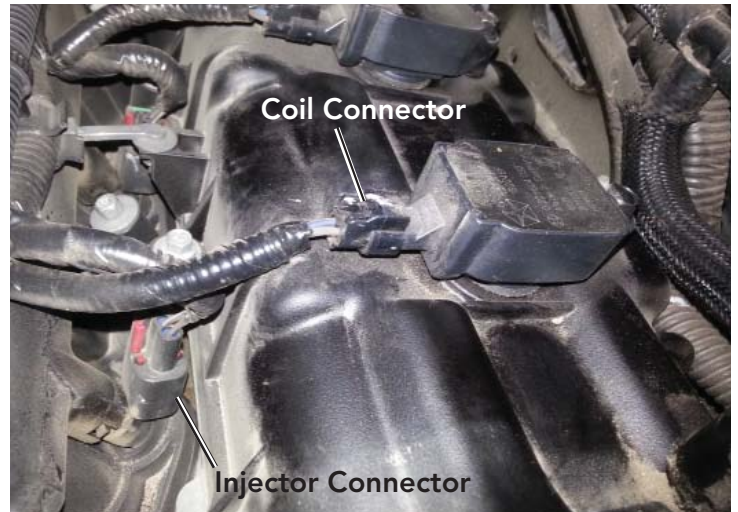

Injector and Coil Connectors

Fuel Injectors

- 17 Use a T-30 torx to remove the (4) fuel rail screws.
- 18 Pull up on the fuel injector rails to separate from the injectors. Have rags ready to soak up spilled fuel.
- 19 Flip fuel rail over. Remove the injectors from the rail. Remove any o-rings from the intake or the fuel rail that did not stay with the injector. Make sure ALL o-rings are accounted for.
- 20 Apply a small amount of grease to the o-rings of the new injectors. Insert the injectors into the lower intake manifold and push down until they are fully seated. Turn the injector connector to face away from the center of the engine.
- 21 Align the fuel rail with the injectors in the manifold and push the rail down until the injectors are seated into the rail. The mounting holes should sit flush with the lower intake manifold.
- 22 Reinstall the (4) T-30 torx screws that hold down the fuel rails.
- 23 Reinstall the coils and coil screws.
- 24 Reinstall the intake manifold. Installation is reverse of removal.

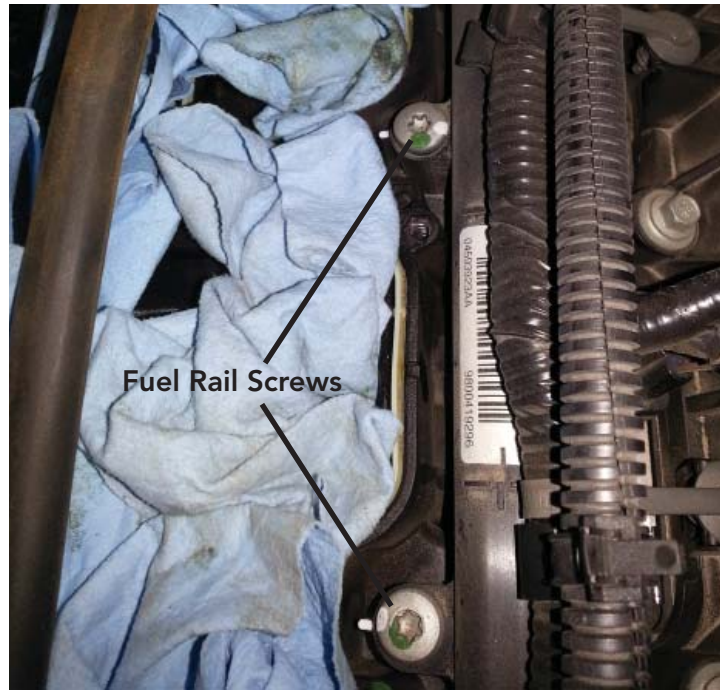

Transmission Cooler Line Connections



Fuel Rail Flush With Manifold



Injectors and Fuel Rail Finished

ALTERNATOR RELOCATION

- 1 Use a 10mm to remove the bottom timing cover bolt on the driver's side.
- 2 Use a 10mm to remove the timing cover bolt just below the water pump pulley.

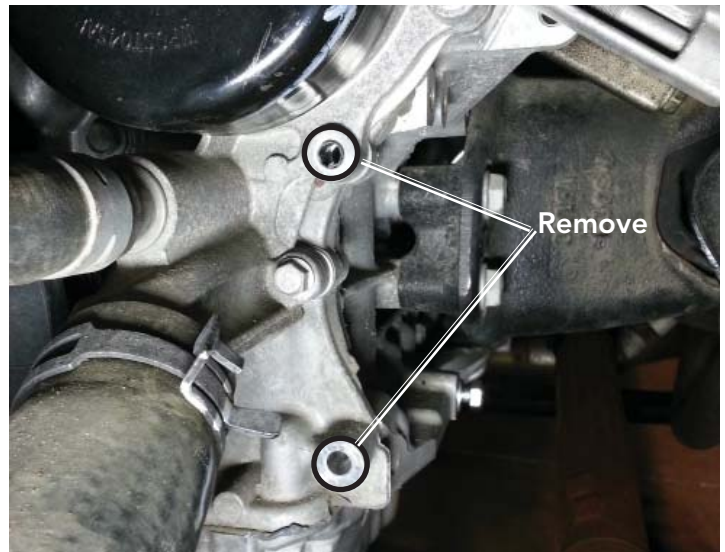

Timing Cover Bolts

- 3 Set the alternator bracket in front of the timing cover and insert the supplied M6 x 60mm SHCS through the bracket and into the timing cover. Tighten with a 10mm.



Alternator Bracket Mounted

- 4 To provide clearance for the suspension, the tab on the alternator shown to the right will need to be cut off. Be sure the metal shavings do not go into the alternator.



Alternator Tab Trimmed

Alternator Relocation

- 5 Attach the alternator to the bracket using the supplied M10 x 110mm and M10 x 130mm bolts and washers. The longer M10 bolt goes to the mounting point closest to the driver's side. Tighten with a 17mm.
- 6 From underneath the vehicle, insert the supplied M8 x 20mm bolt and washer through the alternator brace and into the tapped hole on the block. Leave loose.
- 7 Slide the other end of the brace over the exposed alternator mounting bolt. Start the washer and locknut over the bolt. Leave loose.
- 8 Adjust the brace so that it fits flush against both the block and the alternator bracket. As the bolt and nut are tightened, the brace should not be in a bind. Use a 17mm to tighten the nut and a 13mm to tighten the bolt.



Alternator Mounted to Bracket



Alternator Brace Installed

BUMP STOP

- 1 On the drivers and passengers side front, slide a bump stop through the coil spring with the countersink facing up.
- 2 Place the bump stop on top of the spring perch. Insert a 5/16" bolt with washer through the bump stop and through the spring perch.
- 3 On the drivers side. Screw the lock-nut onto the bolt from under the spring perch. Tighten the bolt and nut.
- 4 On the passenger side. Remove the bolt holding the brake line bracket on the back side of the spring perch. Move the brake line and bracket out of the way. This will allow room to install the nut on the bump stop bolt.
- 5 Install the passenger side lock-nut. Re-install the brake line bracket.



Bump Stop Installed



Brake Line Bracket Bolt



Bump Stop Nut Installed

MAIN BRACKET ASSEMBLY

- 1 Using a 16mm remove the factory idler from the bracket. Note the orientation of the pulley. Remove the stamped washers and the bolt from the pulley they will not be reused.



Remove Idler

- 2 Mount the idler pulley to the main bracket as shown to the right using a supplied idler shaft, M10x 50mm bolt and washer. Use red thread locker on the threads when securing the bolt.



Idler Installed

- 3 Use a 13mm to remove the driver's side idler pulley. Note which side of the pulley sits against the timing cover. Separate the pulley from the shouldered bolt. The pulley will be reused, the bolt will not be reused.

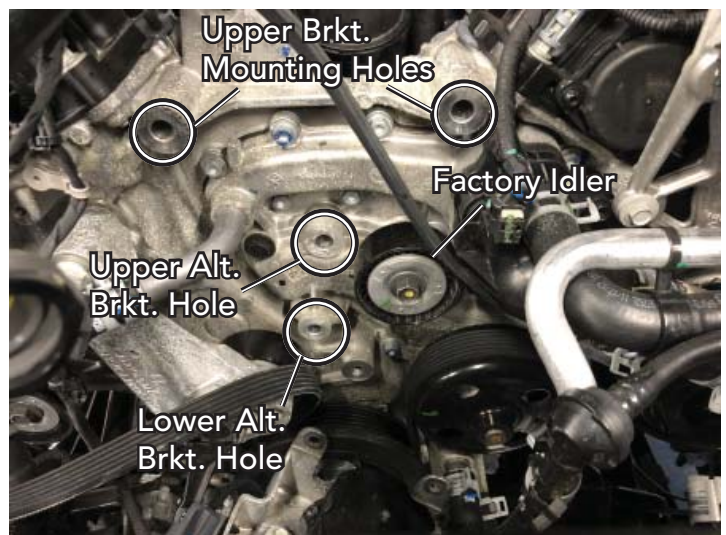

Bracket Mounting Holes

- 4 Use a 17mm to install the supplied M10x 60mm bolt and washer into the upper alternator bracket hole.



Timing Cover Secured

- 5 Insert the supplied idler shaft into the factory idler pulley with the idler shaft on the side of the pulley opposite timing cover.



Idler Shaft In Factory Pulley

Main Bracket Assembly

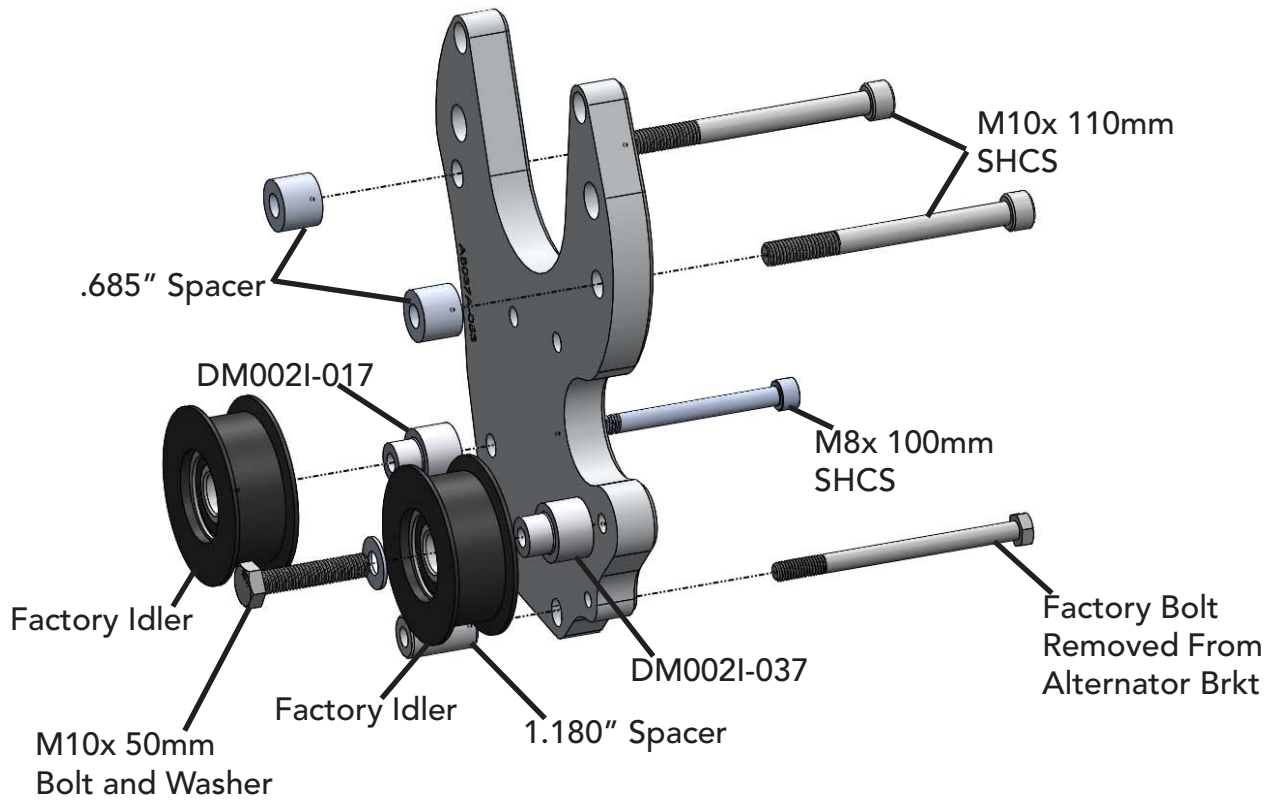

- 6 Assemble the main bracket by inserting the (2) supplied M10x 110mm SHCSs (Socket Head Cap Screws) through the bracket as shown.
- 7 Slide the (2) .685" long spacers over the SHCSs on the back side of the main bracket.
- 8 Set the bracket assembly up to the timing cover. Align the bolts with the alternator mounting holes. Start the bolts, but leave loose.
- 9 Align the pulley and idler shaft with the idler pulley hole in the timing cover and with the lower mounting point on the main bracket.
- 10 Slide the supplied M8x 100mm SHCS through the main bracket, the idler shaft, the idler, and into the timing cover.



Main Bracket Mounted

- 11 Following the schematic to the right loosely install the supplied belt by feeding the belt between the tensioner and the idler and feeding it up between the timing cover and the supercharger bracket. Continue routing the belt over the other accessories. Leave the belt off of the factory idler, being sure to leave the belt loose enough to put around the procharger pulley.

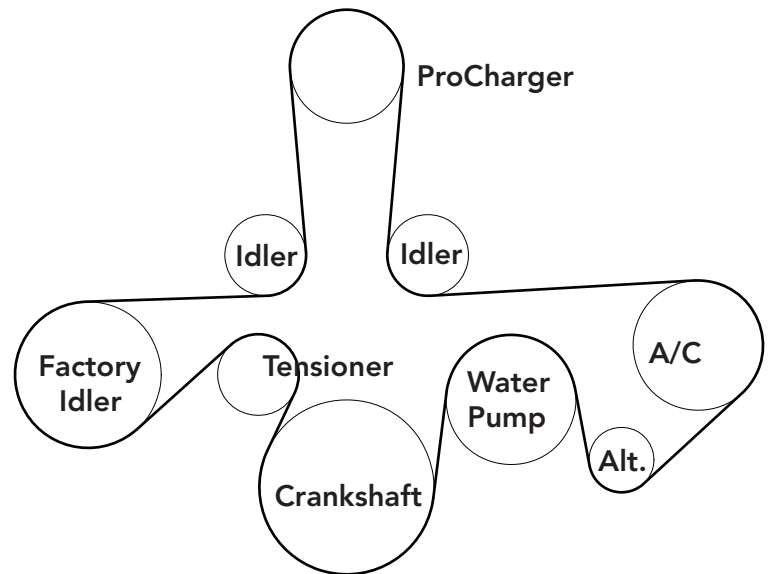

Belt Schematic

- 12 Slide the 1.180" spacer behind the bottom of the bracket and insert the factory bottom alternator bracket bolt (removed earlier) through the bottom bracket hole, through the spacer and into the lower alternator bracket hole. Tighten all bracket hardware at this time.



Main Bracket Mounted

PROCHARGER HEAD UNIT

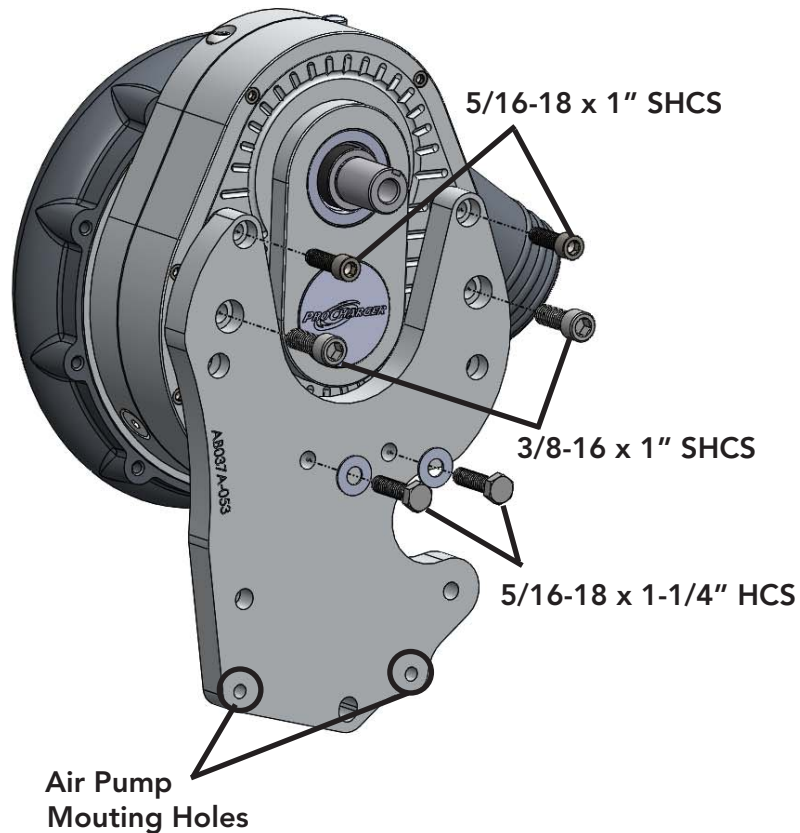

- 1 Fill the supercharger with (1) 6 ounce bottle of supplied blower oil.

✓ **Tech Tip:** A syringe with clear hose is included with the supercharger kit for easy removal of oil from the supercharger without having to remove the supercharger from the bracket.

- 2 Mount the ProCharger onto the main bracket using the provided 5/16" SHCS's on the top (2) holes, the 3/8" SHCS's on the middle (2) holes, and the 5/16" bolts in the bottom (2) holes. Tighten the fasteners with a 5/16 allen, 1/4 allen, and a 1/2" wrench.



Supercharger Mounted

- 3 Install the belt over the supercharger pulley.
- 4 Insert a 1/2" breaker bar and extension into the square slot on the tensioner. Push the breaker bar towards the driver's side. A constant, steady pressure on the breaker bar will slowly compress the tensioner. Once the tensioner is fully compressed, slide the belt over the factory idler pulley. Release the tensioner. Ensure the belt is properly over each pulley and that it is aligned with each pulley rib.
- 5 Align the air pump bracket bolt holes with the (2) threaded holes on the main bracket. Secure the air pump bracket to the supercharger bracket with the factory air pump bracket bolts.



Air Pump Mounted

ALTERNATOR WIRING

- 1 Locate the alternator power wire extension. Remove the black plastic power wire cover from the factory power wire. Use the supplied 5/16 bolt, washers and nut to connect the extension wire to the factory power wire.
- 2 Use electrical tape to wrap the exposed portions of the wire connection. Then wrap the connection area with the supplied insulation sleeve. Additional sleeve material is included if you want to double-wrap the connection.
- 3 Locate the alternator extension harness. Plug the factory connector into the extension harness.
- 4 Route the power wire and the harness extension down along the heater lines and to the alternator. Ensure the wires are clear of the belt and cooling fan.
- 5 Plug the harness into the alternator connector.
- 6 Slide the factory power wire cover over the end of the power extension wire. Slide the power wire over the power stud on the alternator and tighten down with the factory nut. Snap the power cover over the stud on the alternator.
- 7 Cover the extension harness and power wire with the supplied 5/8" wire loom. Secure with zip ties.

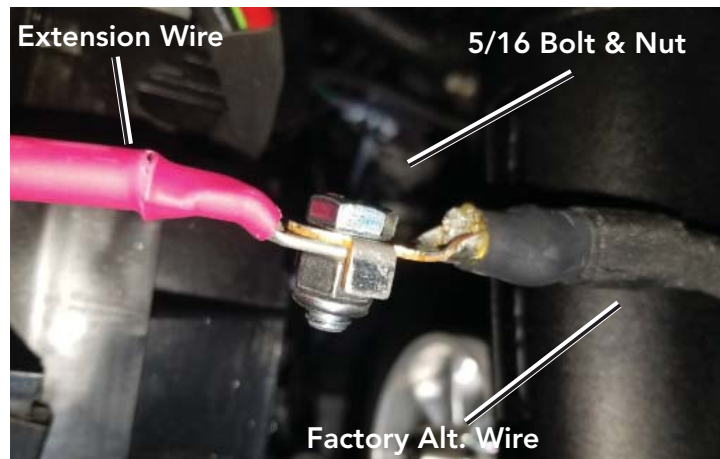

Extending the Alternator Power Wire



Harness and Power Wire at Alternator



Plastic Cover Installed Over Power Wire

INTERCOOLER AND TUBE ROUTING

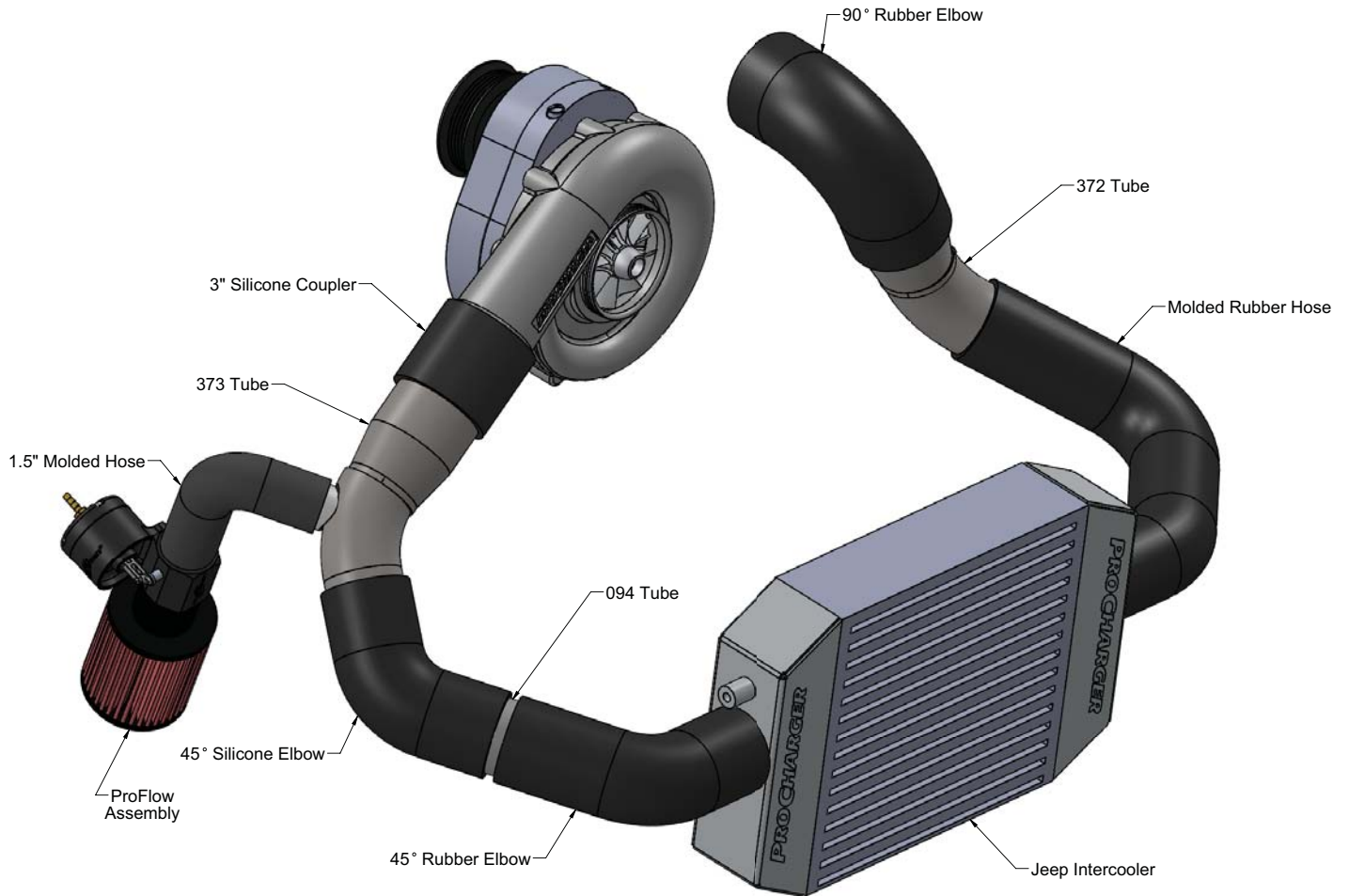

Intercooler and Tubing

✓ **Tech Tip:** Applying a small amount of WD40 or glass cleaner on the connections will help with adjustment. Leave all hose clamps loose until all tubes have been installed and adjusted.

1 Using a T-30 torx socket, remove (4) screws securing the support bars on the radiator support. Remove the support bars (these will not be reused).



Remove Support Bars

2 Remove the (2) push pins on the right side plastic air deflector. Remove the deflector.



Remove Air Deflector

3 On the left side of the radiator, remove the (2) air inlet tube bolts with a T-20 torx socket. From the engine bay lift up on the air tube to remove it. Remove the (2) push pins and remove the air deflector.

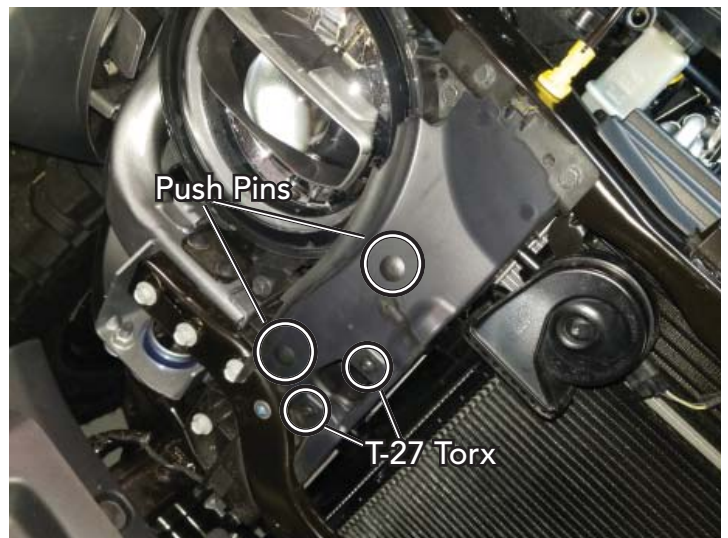

Remove Air Deflector

- 4 Remove the (4) push pins in the radiator cover then remove the cover.

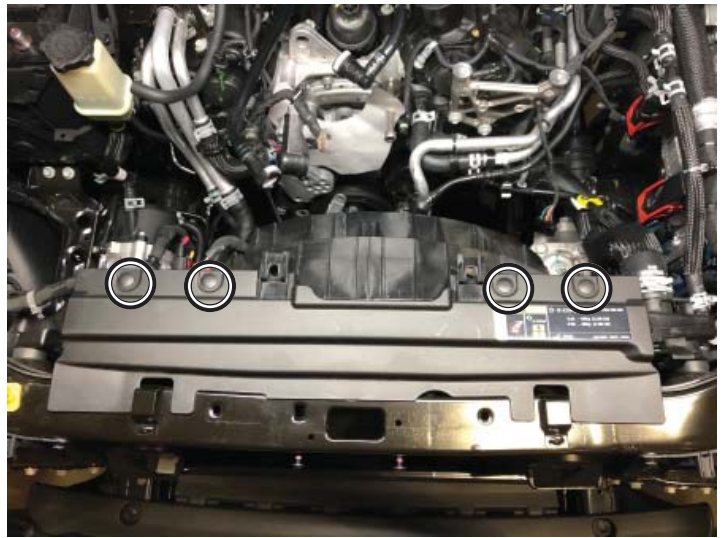

Radiator Cover

- 5 Remove the top (2) radiator bolts with a 10mm.



Radiator Support Mount

- 6 Lift the radiator up and out of the bottom mount.



Lift Up Radiator

Intercooler and Tubing

- 7 Insert the provided radiator support spacer into the bottom radiator mount from the bottom. Bolt the provided radiator support bracket to the support spacer with 3/8" bolt and lock washer. Repeat for the other side.
- 8 Lift the radiator up and into the new radiator support brackets.
- 9 Unplug the harness to both horns and use a 10mm to remove the bolts securing the horns to the radiator support. Set the horn assembly's and bolts aside.
- 10 Using a 3/8" drill bit carefully drill a hole in the middle of the bottom a/c condenser tab as shown to the right. Repeat for the other side.

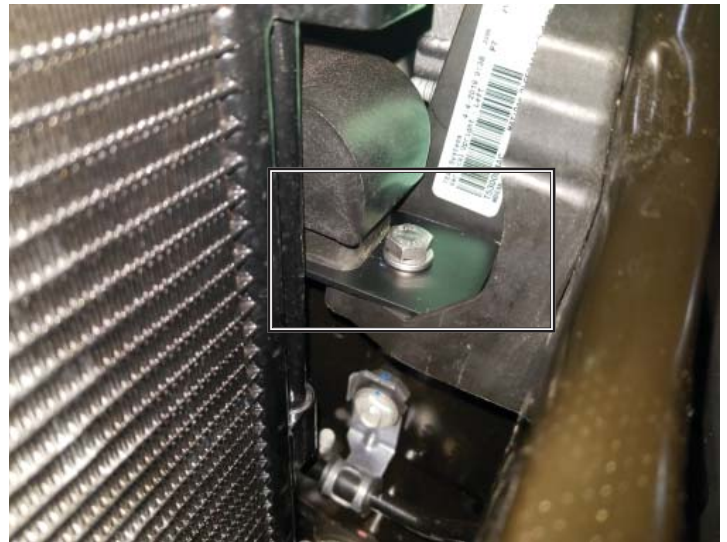

Radiator Support Mount



Remove Both Horns



Drill Hole (Left Side Shown)

- 11 Insert the (4) provided clip nuts over the holes on the tabs of the a/c condenser indicated by the red arrows to the right.

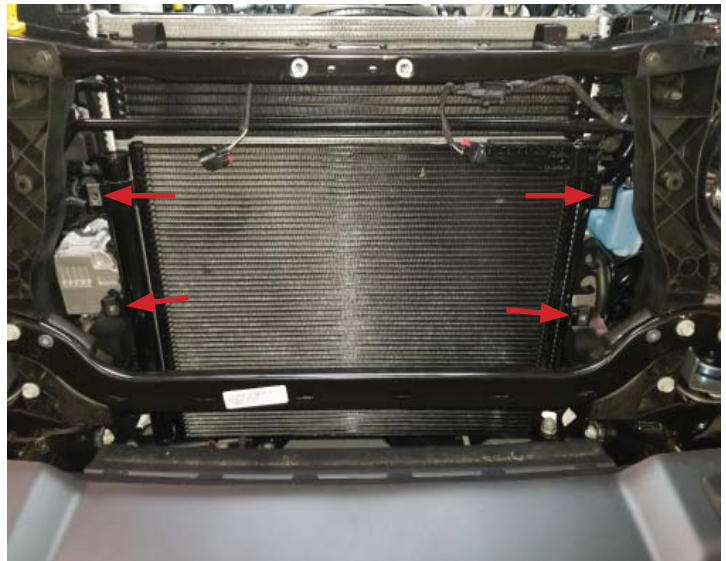

Clip Nut Mounts

- ✓ **Tech Tip:** Pay close attention to the orientation of the intercooler. The inlet and outlet should be closer to the bottom as shown.

- 12 Loosely mount the intercooler brackets to the intercooler using the provided 3/8" bolts and washers. Loosely bolt the intercooler with brackets to the clip nuts installed earlier. Center the intercooler and tighten all hardware. Reference the picture to the right for bracket locations.



Driver's Side I/C Brackets



Passenger's Side I/C Brackets

Intercooler and Tubing

- 13 Flatten the tab on both horns and using a 10mm loosen the horn nut.



Flatten Tab

- 14 Loosely mount the horns into the stock location, position the horns so they don't touch the intercooler (the brackets may need to be bent) and tighten all the hardware. Re-connect the wiring harness'.



Horn Mounted

- 15 Insert the provided 0.205" spacers between the radiator support and the upper radiator mounts. Secure with the factory hardware.



Upper Radiator Spacers

- 16** Slide the short end of the rubber 45° coupler onto the passenger side of the intercooler as shown. Secure with a #40 hose clamp.



Passenger's Side I/C Connection

- 17** Insert tube #094 into the open end of the rubber 45° coupler. Secure with a #40 hose clamp.



Tube #094

- 18** Slide the silicone 45° coupler over tube #094 and position as shown. Secure with a #40 hose clamp.



Silicone 45° Coupler

Intercooler and Tubing

- 19 Insert the surge tube #373 into the silicone 45° coupler as shown. Secure with a #40 hose clamp.
- 20 Complete the connection to the ProCharger using the 3" silicone coupler. Secure with the provided 3.25" T-bolt clamps.



Discharger Tubing Complete

- 21 Remove the IAT sensor from the stock inlet tube. Insert it into tube #372.

! **Note:** The sensor can only be installed in one direction. Note the direction of the lock on the bung and on the sensor. The sensor must be inserted and turned until the locking tab slides over the bung lock.



IAT Sensor Lock Tab Direction

- 22 Slide the 45° side of the molded rubber hose onto the driver's side of the intercooler. The 90° leg goes into the engine bay.
- 23 Trim the fan shroud to allow room for the throttle body tube as shown to the right.
- 24 Insert the 2-1/2" end of tube #372 into the driver's side molded tube in the engine bay. Secure with a #40 hose clamp.

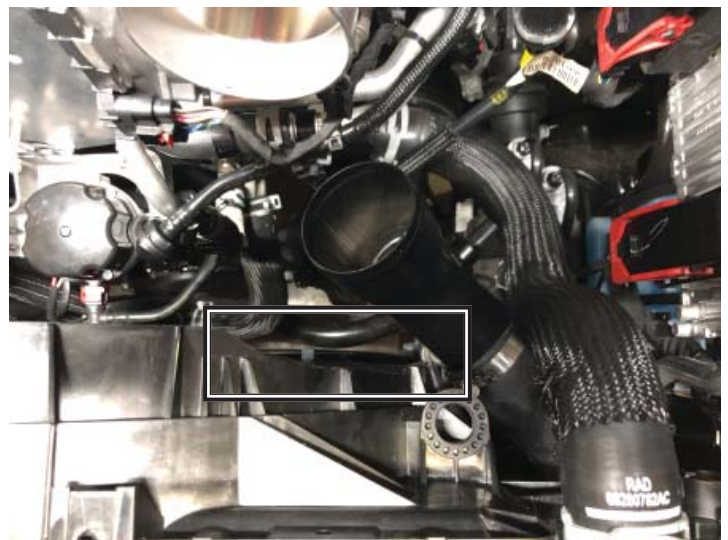

#372 Tube Installed / Fan Shroud Trimmed

- 25 Slide the 90° rubber elbow over the 3" end of tube #372, then over the throttle body. Secure with 3.25" T-bolt clamps.
- 26 Plug the in the IAT sensor.



Throttle Body Tube Installed

SURGE SYSTEM

- 1** Trim the short leg of the 1.5" moulded 90° rubber hose to clear the electrical box. Secure with a #24 hose clamp.
- 2** Insert tube #168 into the open end of the moulded rubber hose. Secure with a #24 hose clamp.
- 3** Slide one end of the supplied 1-1/2" flexible hose over tube #168. Route the hose down towards the frame. Use zip-ties to secure the hose up and out of the way of the suspension links of the front housing. Secure with a #24 hose clamp.
- 4** Route the flexible hose towards the front bumper over the sway bar. Be sure to use zip-ties to keep the hose from being contacted from suspension components.



Moulded Rubber Hose Installed



Surge Hose Routed



Surge Tube Routed

- 5 Install the provided filter onto the end of the surge valve.



Surge Valve Installed

- 6 Install the surge valve onto the end of the flexible hose, position in the bumper as shown to the right. Point the barb fitting to where it can be reached by a vacuum line. Ensure the valve linkage is unobstructed. Secure with the #24 hose clamp and surge valve mount combination.



Surge Valve Installed

- 7 Secure the surge valve to the front bumper support as shown using the supplied 5/16 self tapping screw.



Surge Valve Installed

PCV SYSTEM

- 1 Unhook the PCV line from behind the throttle body, follow the tube to the back of the passenger side valve cover. Unhook the line from the valve cover and remove it from the vehicle.



Remove PCV Line

- 2 Carefully cut the plastic tube to remove the fittings from the ends.



Remove Both Fittings From Tube

- 3 If not already completed, screw the plastic fittings into the plastic check valve. Locate the supplied 5/8" rubber hose. Cut a 3" section of hose, slide one end onto one of the 90° fittings. Slide the other end onto the end of the check valve, be sure the arrow of the check valve points towards the fitting. Secure with the provided #10 hose clamps.



90° Fitting and Check Valve

- 4 Connect the fitting with the check valve to the port behind the throttle body.

- 5 Cut a 2.5' section of 5/8" hose and secure it to the remaining 90° PCV fitting with a hose clamp. Route the fitting behind the intake and connect the the port on the valve cover, connect the other end to the open port of the check valve. Secure with a #10 hose clamp.



PCV Hose Routed

- 6 Cut the plastic PCV line that went to the factory airbox at the jog as shown to the right.



Hard PCV Line Trimmed

- 7 Slide the remaining section of 5/8" hose over the cut plastic line and secure with a #10 hose clamp.

- 8 Assemble the vacuum manifold with the 3/8" straight barb in one end and the 3/8" 90° fitting in the other end. Plug (2) of the 1/8" ports with the 1/8" brass plugs (these ports are also a perfect spot for connecting a boost gauge to). Install the 1/8" barb fitting into the remaining 1/8" port.



Vacuum Manifold Assembled

PCV System

- 9 Unplug the brake booster vacuum reference line from behind the throttle body. Remove the mesh cover from the hose.
- 10 Trim the hose as shown to the right, be sure to leave enough hose to insert the barb fittings for the vacuum manifold. **DO NOT REMOVE THE ONE WAY CHECK VALVE ON THE HOSE.**
- 11 Install the 90° barb fitting of the vacuum manifold into the hose on the throttle body and insert the straight barb into the remaining vacuum line. Secure with the supplied #08 hose clamps.

! **Caution:** Not securing or kinking the vacuum line may cause a loss of brakes, possibly resulting in property damage or death.

- 12 Route the supplied vacuum line from the 1/8" barb on the vacuum manifold to the barb fitting on the surge valve. Ensure the line is free from any moving parts or the exhaust. Secure the line with the provided zip-ties.



Vacuum Hose Trimmed



Vacuum Manifold Installed

AIR INLET

- 1 Trim the fan shroud as shown to the right this will make room for the air inlet on the supercharger.

✓ **Tech Tip:** Additional trimming may be required once the air inlet is installed just be cautious as to not get into the fan blade.

- 2 Slide the 3-1/2" 90° rubber elbow over the inlet of the ProCharger. Secure with a #60 hose clamp.

- 3 Install the supplied 3/8 NPT x 5/8" 90° hose barb into the bung on tube #374. Face the bung towards the firewall.

- 4 Insert the supplied air filter over the longer leg of tube #374.

- 5 Insert the open end of tube #374 into the 90° rubber elbow. Tighten with a #56 hose clamp.

- 6 Adjust the air filter and tighten with the supplied hose clamp.

- 7 Trim the 5/8" PCV hose installed earlier to length and install onto the 5/8" barb fitting and secure with a #10 hose clamp.



Trim Shroud



Air Inlet Installed



PCV Hose Connection

FINAL ASSEMBLY

- 1 Remove the factory MAP sensor. Carefully remove the o-ring from the sensor.
- 2 Locate the supplied MAP sensor. Cut one ear off the sensor as shown.
- 3 Insert the MAP sensor into the MAP sensor adapter. Secure using one of the supplied 10-24 x 1/2" SHCS. Insert the factory o-ring onto the adapter.
- 4 Install the MAP sensor and adapter into the intake manifold and point towards the front of the vehicle.
- 5 Install the MAP adapter tab to the MAP adapter using the other 10-24 x 1/2" screw. The MAP tab should straddle the tab on the intake manifold, preventing the MAP adapter from turning.
- 6 Locate the MAP adapter harness. Plug the factory harness into the MAP adapter in the orientation shown. Plug the other end into the new MAP sensor.



Note: The MAP adapter harness must be connected in the orientation shown or the ECU will not receive a MAP sensor signal.



MAP Sensor Installed On Adapter



MAP sensor Installed



MAP Adapter Harness Connector

- 7 Re-install the engine cover bracket on the intake manifold.
- 8 Re-install the engine cover.
- 9 Install the grille back into the vehicle.
- 10 Install a 3/8" hose clamp on the line behind the throttle body on the front of the intake as shown to the right.
- 11 Hook the battery negative cables back up.
- 12 Before starting the vehicle, check to be sure everything is clear of the belt and all hardware is secure.
- 13 Locate the CARB Executive Order sticker included with your system. This sticker must be installed in an underhood location that is readily visible.

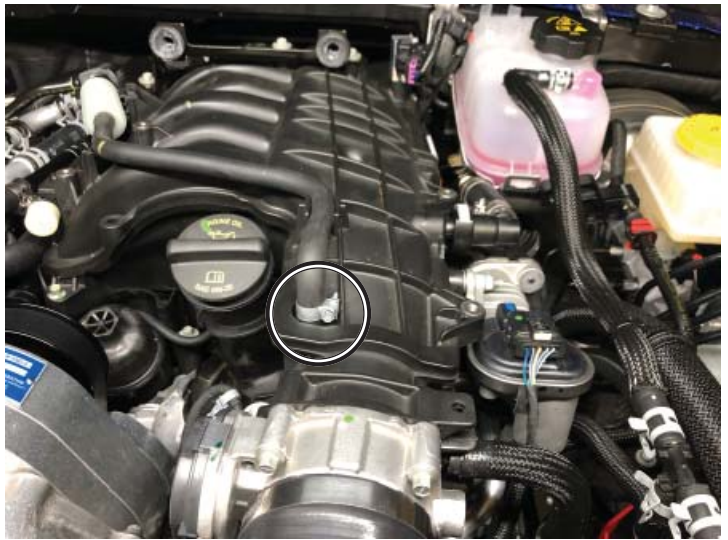

Hose Clamp Installed



CONGRATULATIONS! YOU HAVE COMPLETED THE INSTALLATION OF YOUR NEW PROCHARGER SUPERCHARGER SYSTEM. READ THE FOLLOWING PAGES CAREFULLY FOR OPERATION AND MAINTENANCE INSTRUCTIONS, AS WELL AS WARRANTY INFORMATION.

OPERATION AND MAINTENANCE

Cold Starting

Never race your engine and ProCharger supercharger when your engine is cold. Allow the water temperature to climb into operating range for several minutes before driving above 2,500 rpm, to ensure adequate oil lubrication.

Fuel Quality

With a properly installed intercooled ProCharger supercharger system, detonation should not occur. For the best performance and reliability, use premium grade fuel (91 octane or higher). Listen for signs of detonation after refueling, and after replacement or modification of any fuel system component(s). If detonation occurs, reduce the throttle and locate the source.

Ignition System Maintenance

If your spark plugs are more than a year old or have more than 10,000 miles logged, you should consider changing them before driving your vehicle under load. Spark plug wires should be changed if visibly damaged or when resistance exceeds factory specifications.

Air Filter Maintenance

Your air filters should be cleaned periodically, potentially as often as every 10,000 miles or 6 months, even though a service interval of 50,000 - 100,000 miles is quoted by the manufacturer under normal driving conditions. A clogged air filter will result in decreased boost levels and vehicle performance. Be sure to re-oil the cleaned filter before re-installing. Always operate your vehicle with an air filter; failure to do so may result in damage to your ProCharger supercharger and personal injury!

Belt Replacement

The serpentine belt, which turns your ProCharger supercharger, will stretch after initial run-in, and should be retightened after the first hundred miles. Tighten the belt sufficiently to avoid slippage, but do not overtighten. Overtightening the belt could cause damage to the ProCharger supercharger's precision bearings. When re-installing the belt, use the belt routing diagram in this manual. If you reuse a thrown belt and find that it needs frequent re-tightening, the belt is damaged and should be replaced. Gates Micro-V belts can be bought from ATI or from your local parts store.

ProCharger Oil Change Intervals

The first oil change should be performed at 500 miles and at 6,000 mile intervals thereafter. Clean the drain plug after every oil change. Drain oil by removing the drain plug. Clean off the drain plug before re-installing.

ProCharger Oil Level

The ProCharger supercharger's oil level must be checked periodically to ensure the proper lubrication. The dipstick can be loosened using a flat blade screwdriver or a coin. When installed, the oil level should remain between the minimum (MIN) and maximum (MAX) indicators at all times.

! **Warning:** Filling the ProCharger higher than the maximum level on the dipstick can lead to bearing and seal damage. The supercharger is a sealed unit and should not normally require the addition of oil between service intervals. If excessive usage is noted, the unit should be sent to ATI for inspection and repair. The dipstick fitting should be firmly tightened after changing or checking the oil level.

General

When removing the dipstick, be sure to retain the nylon washer. A spare nylon washer and o-ring is included. Use only the ATI supplied nylon washer and o-ring when servicing the oil dipstick and drain plug. A discoloration of the oil and residue on the drain plug may occur during the initial oil changes. This is normal and will gradually decrease. For the proper positioning of the ProCharger supercharger, the serial tag should be pointing upwards. Installing the ProCharger supercharger in another position will cause inadequate oiling and supercharger failure. If you have any questions about the maintenance of your supercharger, contact ATI.

! **Warning:** The supercharger contains no oil from the factory. The unit must be filled prior to use. Use only ATI supplied oil in your ProCharger. The ATI oil has been specially formulated for the bearings in the ProCharger and use of oil other than that supplied by ATI will void your warranty.

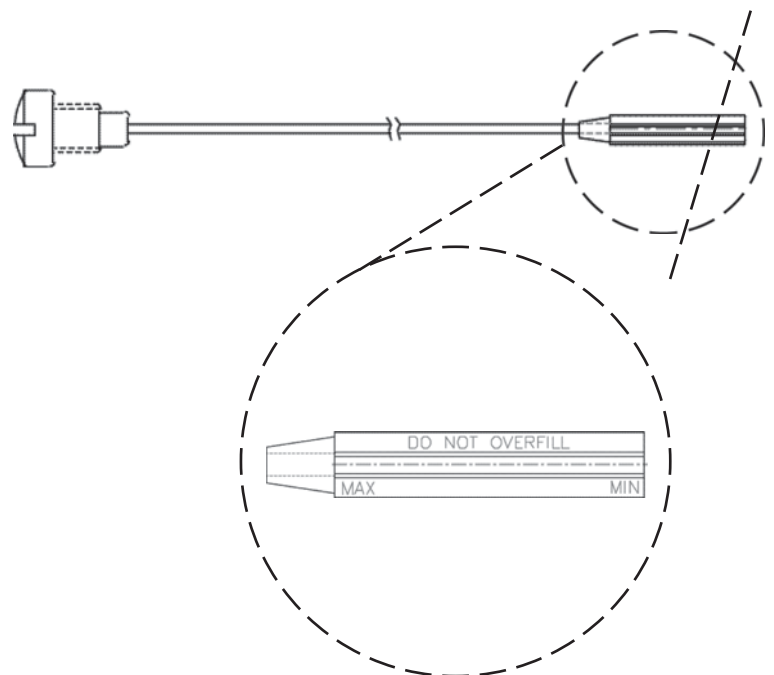
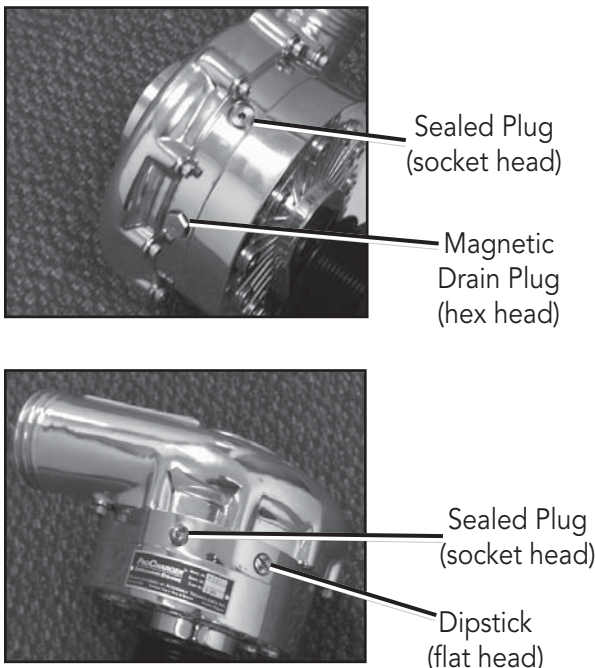

LIMITED WARRANTY

Accessible Technologies, Inc. (ATI) provides a limited twelve (12) month warranty on the ProCharger supercharger against defects in materials and workmanship unless otherwise specified. This limited warranty starts on the date of original purchase from your local dealer, or date of shipment from the factory. This limited warranty coverage is extended only to the original owner and excludes hoses, sleeves, and electronic components manufactured by other companies. IF THE SUPERCHARGER'S DRIVE RATIO IS ALTERED IN ANY WAY FROM THE FACTORY SETTING, WARRANTY COVERAGE IS VOID. USE OF ANY PULLEY NOT MANUFACTURED OR SUPPLIED BY ATI VOIDS ALL WARRANTY COVERAGE. ATI's warranty obligations are limited to the terms below:

ATI agrees to honor a warranty claim at its sole discretion and only after inspection at the ATI factory. No warranty will be honored if any part of the product is found to have been improperly installed, tampered with, mishandled, or misused in any way. Disassembly of the ProCharger supercharger or removal of the ProCharger supercharger's serial plate voids all warranties. Claims for freight damages should be directed to the freight company.

If ATI's limited warranty applies, your product will be repaired or replaced at ATI's discretion and shipped back. If the limited warranty does not apply, ATI will advise you of the specific reason, cost of the repair, and delivery time. After advising you of this information we will, at your option, either proceed with repairs or return your product to you in the state in which it was received. In either case the product will be shipped to you, insured at replacement value. Therefore, you will pay the return shipping and insurance charges if ATI's limited warranty does not apply to your product.

THE WARRANTY AND REMEDIES SET FORTH ABOVE ARE EXCLUSIVE AND IN LIEU OF ALL OTHERS, ORAL OR WRITTEN, EXPRESS OR IMPLIED. THE DURATION OF ANY AND ALL WARRANTIES ON THE PRODUCTS DISCUSSED ARE LIMITED TO THE PERIOD IDENTIFIED ABOVE. ATI IS NOT RESPONSIBLE IN ANY EVENT FOR DIRECT, SPECIAL, INCIDENTAL OR CONSEQUENTIAL DAMAGES. No ATI dealer, agent, or employee is authorized to make any modification, extension, or addition to this warranty.

To obtain service under this warranty you must do the following during the warranty period:

Phone ATI (913-338-2886) and provide us with the following information:

- ProCharger supercharger serial number.
- Vehicle year, make, model, engine modifications, and other modifications.
- Description of perceived issue.

If a solution to your issue can not be found after the above phone consultation, you will be assigned a return authorization number (RMA). You must then properly package and ship your product, at your expense, to the ATI factory. The product should be carefully packaged in a rugged box.

Include the following information inside the box with your product:

- Copy of your original invoice or receipt.
- Name, address, and daytime telephone number.
- Return authorization number (RMA).
- Vehicle year, make, model, engine modifications, and other modifications.
- Description of perceived issue.

Clearly mark the warranty claim number on the top and one side of the box in characters at least 2" tall. Properly package the product and ship it, prepaid and insured for the retail value of the component(s) being returned, to the following address:

**Accessible Technologies, 14801 West 114th Terrace,
Lenexa, Kansas 66215**

This Page is Intentionally Left Blank

This Page is Intentionally Left Blank



**Accessible Technologies, Inc.
14801 W. 114th Terrace
Lenexa, KS 66215
Phone: 913.338.2886
Fax: 913.338.2879
techserv@procharger.com**

**Accessible Technologies, Inc.
©2019 ATI, All Rights Reserved
Part Number PMJT1A-001 Rev. C**

