



**BLACK HORSE
OFF ROAD**

TEL: 1-866-XANATOS

INSTALLATION INSTRUCTIONS

**3" BEACON BULL BAR
07-18 JEEP WRANGLER
PART#BE-JEWRB/BE-JEWS**

PARTS LIST:

1	3" Bull Bar	4	Hex Bolt M12_35
1	Driver/Left Mounting Bracket 1	4	Small Flat Washers D12(12x24x2.5mm)
1	Passenger/Right Mounting Bracket 1	4	STD Flat Washers D8(8x24x2mm)
2	Mounting Bracket 2	4	Hex Bolt M8_35
2	Nut Plate	4	Lock Washers D8
8	Large Flat Washers D12_32_3	4	Hex Bolt M12_30
8	Lock Washers D12	4	Hex Nuts M12

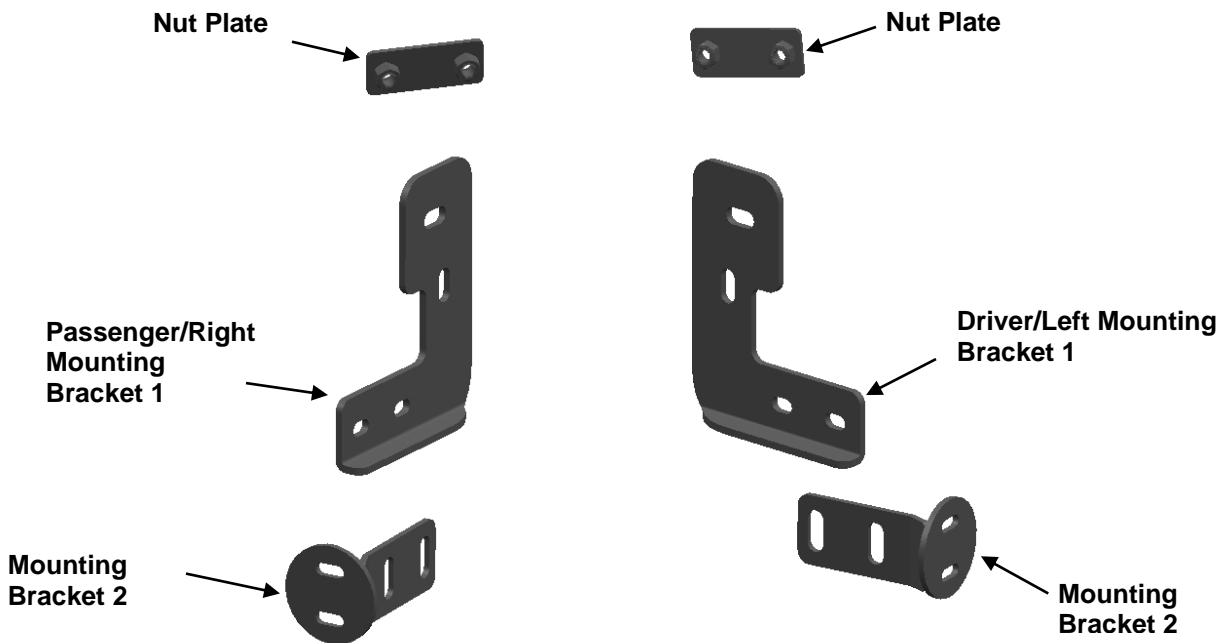

PROCEDURE:

- 1. REMOVE CONTENTS FROM BOX. VERIFY ALL PARTS ARE PRESENT. READ INSTRUCTIONS CAREFULLY. CUTTING IS REQUIRED.**
- Remove the plastic splash guard, **(Figure 1)**, from under the front bumper and place it on a clean, stable work surface.
- Starting on the driver side, insert (1) Nut Plate, **(Figure 2A)**, into the opening in the end of the frame crossmember, **(Figure 2B)**. Line up the lower threaded hole in the Nut Plate with the lower hole in the frame. Select the driver side Mounting Bracket. Bolt the Mounting Bracket 1 to the side of the crossmember with (2) 12mm x 30mm Hex Bolt, (2) 12mm Flat Washer and (2) 12mm Lock Washer inserted through the upper hole in the Bracket, crossmember and into the Nut Plate, **(Figure 3)**. Leave hardware loose at this time.
- Next, select the Mounting Bracket 2, **(Figure 4)**. Bolt the Mounting Bracket 2 to the lower hole in the Mounting Bracket 1 with (2) 12mm x 35mm Hex Bolt, (2) 12mm Flat Washer and (2) 12mm Lock Washer inserted through the Mounting Bracket 2, the lower hole in the Mounting Bracket. Snug but do not tighten at this time.
- With help, position the Bull Bar up to Mounting Bracket 2. Use the included (2) 8 x 35 Hex Bolts, (2) 8mm Large Flat Washers and 8mm Lock Washers to attach the Bull Bar to Mounting bracket 2, **(Figure 5)**. Snug but do not tighten at this time.
- Repeat **Steps 3 – 5** for passenger side Mounting Bracket installation.
- Align the Bull Bar properly and only tighten the Bracket hardware securing the Brackets to the frame at this time. Temporarily remove the Bull Bar.

8. Position the splash guard back up to the vehicle and attach with the factory hardware. Estimate the amount of cutting required to clear the Brackets and Bull Bar. Mark the location of the Mounting Brackets onto the back of the splash guard, **(Figures 6)**. **NOTE:** To maintain the integrity of the plastic Splash Guard, remove only material necessary to clear the Bull Bar and Brackets. Make small cuts and check the fit often before final installation. Reinstall the splash guard with factory hardware.
9. Reinstall the Bull Bar and tighten all hardware.
10. Do periodic inspections to the installation to make sure is secure and tight.

To protect your investment, wax this product after installing. Regular waxing is recommended to add a protective layer over the finish. Do not use any type of polish or wax that may contain abrasives that could damage the finish.

For stainless steel: Aluminum polish may be used to polish small scratches and scuffs on the finish. Mild soap may be used also to clean the Bull Bar.

For gloss black finishes: Mild soap may be used to clean the Bull Bar.

Driver Side Installation Pictured

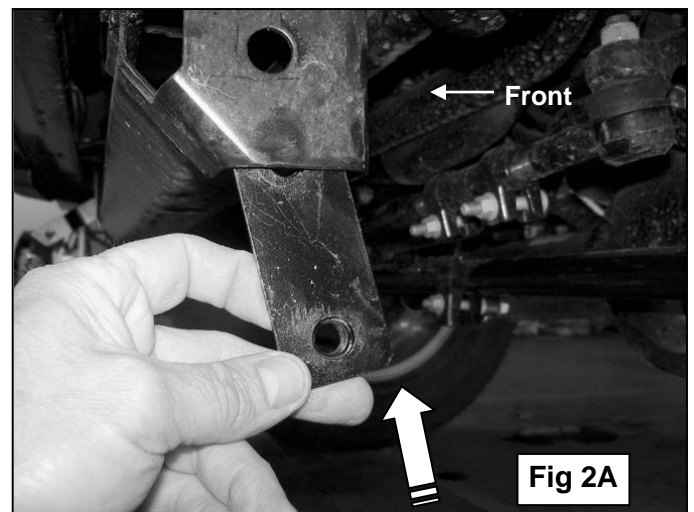
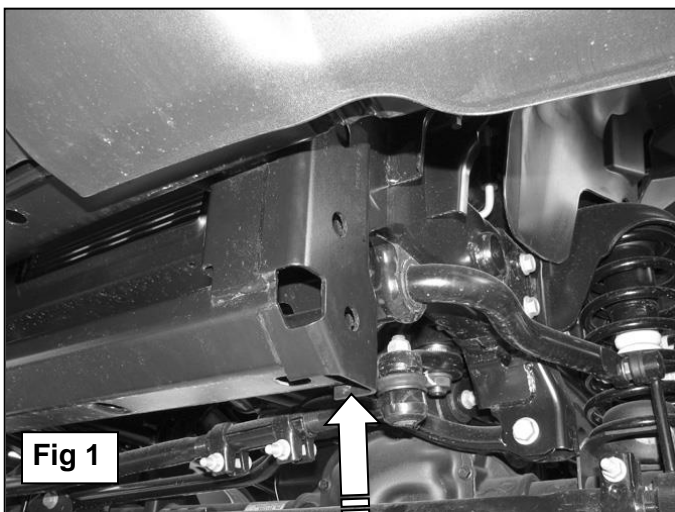

12mm x 30mm Hex Bolt
12mm Lock Washer
12mm Flat Washer(12x24x2.5mm)

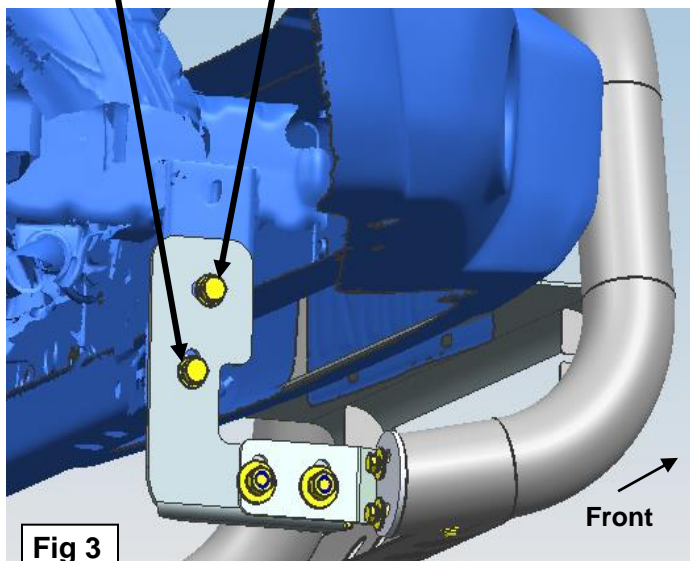

Insert the 12mm Double Nut Plate (2B) into the opening in the bottom of the end of the crossmember with the flat side against the crossmember (Fig 2A) and the hex nuts facing inward (Fig 2B)

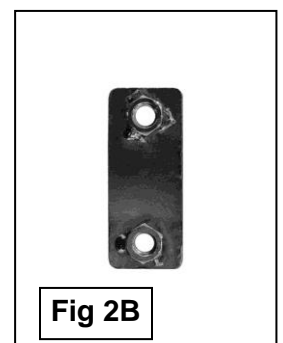

Driver Side Installation Pictured

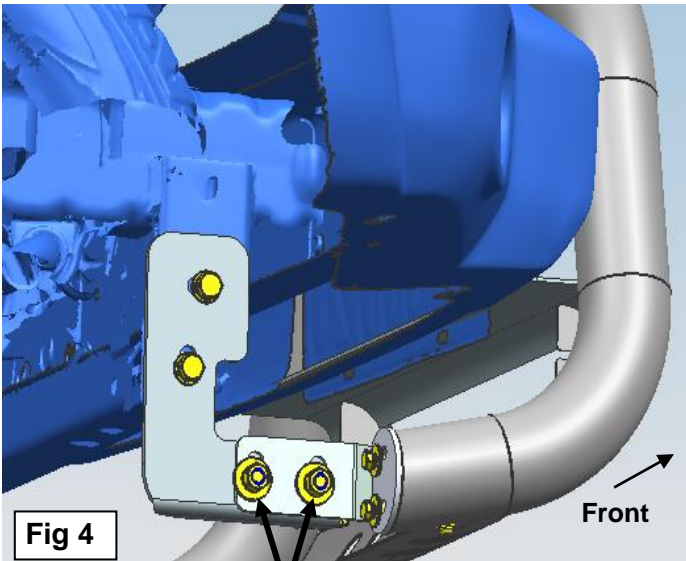

Fig 4

- 12mm x 35mm Hex Bolt
- 12mm Lock Washer
- 12mm Flat Washer(12x32x3mm)

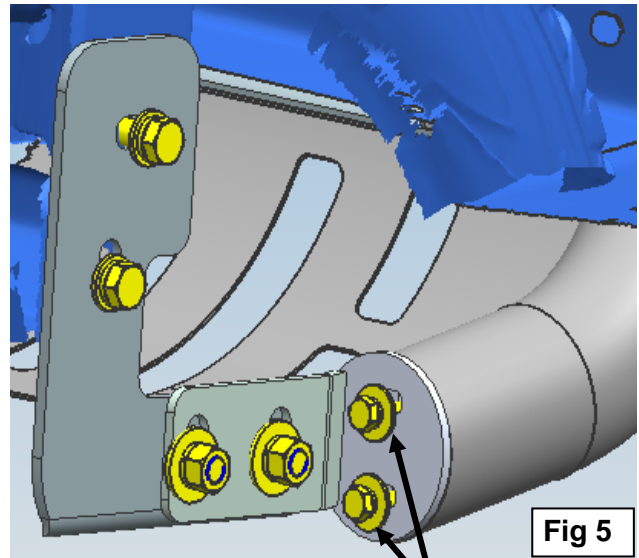
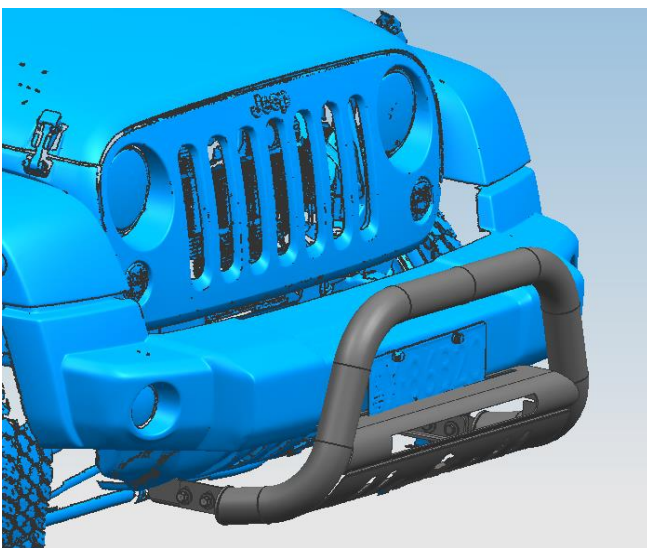

Fig 5

- 8mm x 35mm Hex Bolt
- 8mm Lock Washer
- 8mm Flat Washer(8x24x2mm)



Installation Complete

**Cut two openings to clear the Mounting
Brackets, Support Brackets and Bull Bar**

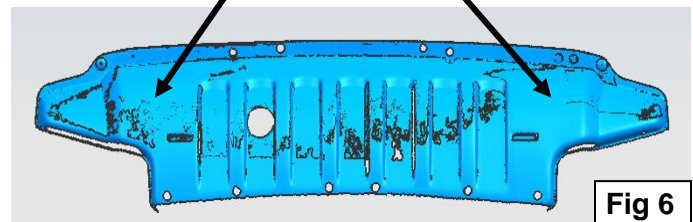

Fig 6

**Area to cut from splash guard
illustrated for example only.**