

QuadraTop® Adventure® Top Fabric Only Replacement

Installation Manual: for 1997-2006 Wrangler (TJ) Vehicles
#11132.80XX



⚠ WARNING ⚠

TO REDUCE RISK OF SERIOUS INJURY OR PROPERTY DAMAGE: READ ALL SAFETY MESSAGES AND UNDERSTAND ALL INSTRUCTIONS AND PROCEDURE *NOTICES* BEFORE ATTEMPTING TO INSTALL OR USE THIS PRODUCT. FOLLOW ALL INSTRUCTIONS AND WARNINGS WITH PRODUCT & VEHICLE OWNERS MANUAL.

⚠ WARNING ⚠

LOSS OF VEHICLE CONTROL INVOLVES RISK OF DEATH OR SERIOUS INJURY, PARTICULARLY TO PARTS OF YOUR BODY NOT RESTRAINED WITHIN VEHICLE. THIS PRODUCT IS INTENDED FOR WEATHER PROTECTION ONLY AND SHOULD NOT BE RELIED UPON TO CONTAIN OCCUPANTS IN THE EVENT OF AN ACCIDENT OR TO PROTECT FROM EITHER GROUND CONTACT OR FALLING OBJECTS.

TO REDUCE RISK OF ACCIDENT OR INJURY:

ALWAYS WEAR SEATBELTS. ALWAYS KEEP HEAD, ARMS & BODY PARTS WITHIN VEHICLE. FULLY SECURE OR STOW THE SOFT TOP BEFORE DRIVING ACCORDING TO INSTRUCTIONS. NEVER TRY TO LATCH OR FOLD SOFT TOP WHILE DRIVING. DO NOT USE IF DAMAGED OR WORN. READ AND FOLLOW ALL INSTRUCTIONS & WARNINGS ACCOMPANYING THIS PRODUCT, IN YOUR VEHICLE OWNER'S MANUAL AND OFF ROAD DRIVING SUPPLEMENT.

⚠ CAUTION ⚠

RISK OF EYE INJURY! SAFETY GLASSES MUST BE WORN AT ALL TIMES WHILE INSTALLING OR MAINTAINING THIS PRODUCT.

Quadratec®
The Jeep® Experts

A Few Words About Product Safety:

Your QuadraTop Adventure soft top is intended to enhance the utility and enjoyment of your off road capable vehicle. Before installation, please review the following safety information and installation recommendations.

Throughout these instructions important safety information is generally preceded by one of three signal words indicating the relative risk of injury, property damage or adverse consequence. **The signal words mean:**

⚠ WARNING ⚠

a hazardous situation which, if not avoided, could result in death or serious injury. You CAN be KILLED or SERIOUSLY HURT if you don't follow instructions.

⚠ CAUTION ⚠

a hazardous situation which, if not avoided, could result in minor or moderate injury. You CAN be moderately HURT and also may suffer property damage if you don't follow instructions.

NOTICE

Careful attention is required to this instruction or operation but does generally not relate to personal injury. Damage to your Quadratec® product or other property may result if you don't follow instructions.

Before You Begin Soft Top Installation:

Congratulations on your purchase of the Fabric only Replacement Adventure Top. This high quality soft top is designed to provide years of protection from whatever nature can throw at you! We have used only the finest materials in creating this soft top but like any product that is exposed to the elements, there is some general maintenance that is required to keep your top looking like new. Please see separate sheet for these important maintenance tips.

Important: For a smooth fit and ease of installation, this top should be installed at temperatures above 72 degrees. Below this temperature, the fabric may contract an inch or more making it difficult to install. We highly recommend taking the top out of the package and letting it sit inside a warm place or in direct sun light for 1-2 hours before you install the top. When warm, this top will install quickly.

When unpacking, check to make sure all parts are included. If any part is missing or broken, please call Quadratec Customer Service at 800-745-6037 as soon as possible.

Important: Note that it is normal for the fabric and glass to contract and wrinkle when stored in the shipping carton. In a few days the fabric and glass will relax & wrinkles will disappear.

Important: Make sure you become familiar with the installation process of this top by reading the following instruction sheet thoroughly.

Thank you again for your purchase and let's start the installation process!



Fabric Replacement Adventure Top for Wrangler TJ:



PARTS LIST:

A) Top Deck	QTY 1
B) Drivers Side Quarter Window	QTY 1
C) Passenger Side Quarter Window	QTY 1
D) Rear Window	QTY 1

REQUIRED TOOLS:

Safety Glasses
Phillips Head Screwdriver
T30 Torx Head and Driver

NOTICE

This Fabric Only Soft Top kit is designed to fit on your TJ Jeep® Wrangler with the original factory hardware and upper door frames (if applicable). Before beginning your installation of this product please be sure you have the correct hardware in good condition.

Installation Prep: Factory Hardware Requirement



This product is designed to fit over your original factory soft top hardware and factory soft upper metal door frames (if applicable).

*Please see **HARDWARE** at left to make sure you have the correct hardware for this top.*

Quadratec®
The Jeep® Experts

Step 1: Remove Existing Top Material



Put on safety glasses. After verifying that you have the correct hardware, remove the existing soft top from the vehicle. This will include removing the existing soft top fabric from the front windshield header. This will require the use of a Phillips head screw driver. To remove the fabric from the front header, fold the top completely down to the rear of the vehicle (see FIG1).



With the tailgate open, unscrew all header screws (8 or 14 screws depending on model year) and two corner screws (see FIG2). Save these screws!

Once the soft top is removed, inspect the hardware to make sure no parts are bent or missing. Once it is determined that the hardware is correct and not damaged, proceed to step two.

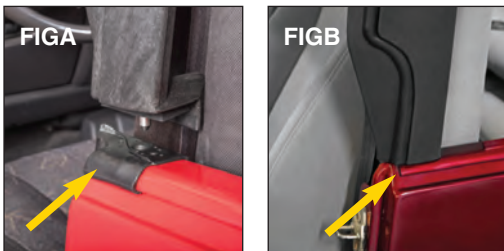

Step 1A: Remove Door Surround Seals

Please Note: If you have the rubber seal shown in FigA this seal must be removed before you install the fabric top over your factory door surrounds as shown in FigB.

Step 2: Remove the Factory Rear Bow



After removing the soft top fabric from your existing hardware, raise the front header up and close the front windshield latches to keep the header from falling back. The hardware system should now look like the picture in Fig 3.

Using a Phillips head screw driver, remove the fabric mounted to the rear bow and to the center bow. Repeat on the other side (Fig 4). If the fabric is mounted to the Rear & center bow with rivets, you will either need to drill out the rivets or cut the fabric off the rear and/or center bow. Using a T-30 Torx

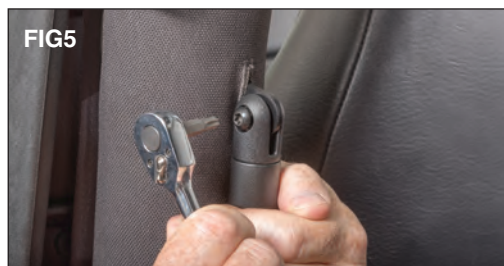

head and driver, remove the rear bow from the bottom bow bracket mounted on the roll bar (Fig 5). Repeat this on the other side of the vehicle.

Your rear bow should now be removed.

Step 3: Install Top Fabric on the Front Windshield Channel

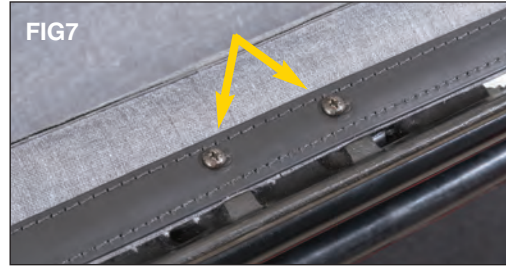

With the Front header all the way folded down towards the rear of the vehicle and the rear tailgate open, lay the soft top fabric inside the vehicle, backing side up, with the header plastic strip facing up on top of the windshield header. See FIG6.

Locate the center hole or two center holes on the plastic strip and secure the center of plastic header using the screw(s) that were removed in step one. See FIG7. Proceed to install the remaining seven or thirteen header screws (depending on model year) along the plastic header lining them up with the holes on the front header itself.

Lift up the header and wrap the corner pockets around the ends of the front Header lining up the corner screws with the corner holes in the header. Install the two corner screws (see FIG8).

Step 4A: Installing the Top Deck to the Jeep®



With the fabric installed on the header, fold the top and header forward so it rests on the windshield (Fig 9)

Un-clip the sun visors and pull the top down to engage the header clamps on each side of the windshield and secure the Header to the windshield (FIGs 10, 11 & 12).

Step 4B: Installing the Top Deck to the Jeep®



Once the front header is secured, go to the rear corner of the Top deck and locate the rear corner straps.



Thread the straps down and under the seat belt mount as shown in FIGs 13 & 14.



Thread the strap through the buckle (see FIG15). Repeat this on the other side of the vehicle and while pulling towards the rear of the vehicle, tighten



one strap and then the other side strap tightening up the top deck.

Do not tighten completely (FIG16).



IMPORTANT: The top deck **MUST** be centered on the rear of the vehicle for the windows to fit properly.

When tightening the rear straps notice the location of the rear bar sewn into the pocket on the top deck. It needs to be centered on the rear roll bar legs.

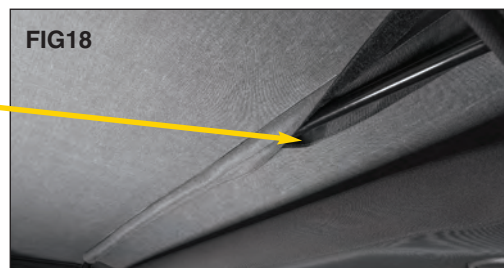

Once the rear straps are secured (but not tightened all the way), go inside the Jeep and locate the long center bow flap.

Wrap this bow flap tightly around the center bow and secure it with the hook and loop fastener (FIGs 17 & 18).

Step 5A: Install the Quarter Windows to the Top Deck

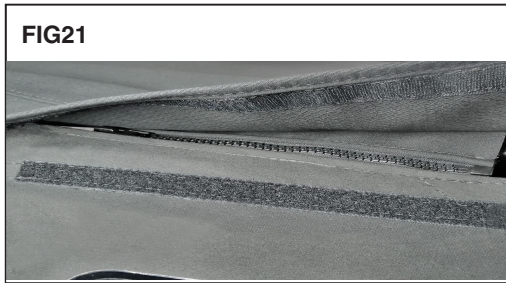

To ensure the top is centered on the vehicle you will be installing the two quarter windows and the rear window to the top deck and to each other before securing it to the vehicle body.

This will allow you to line up all window zippers and attachments. The rear corner straps and header will need to be re-tightened and re-clamped before using the top.

Pro-Install TIP: To make this as easy as possible, you may have to release the front windshield header (release but not un-hook) and loosen the rear corner straps installed in Step 4B.

Locate the drivers rear quarter window. Line up the driver's side Quarter window to the zipper on the deck and zip it as shown in FIG's 19, 20, 21 & 22 Repeat this on the passenger side of the vehicle.

Step 5B: Install Rear Window to the Top Deck

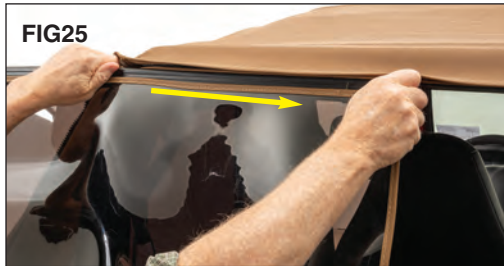

Locate the rear window and line up and slide the rear window into the "C" Channel located at the top of the rear portion of the top deck (FIGs 23, 24 & 25). Once both quarter windows are secured to the top deck, line up the

driver's side rear zipper on the quarter window and on the rear window and zip it down a few inches (FIG 26).

Repeat this on the passenger side of the rear window.



You may have to lift the quarter window up to secure this second zipper. Once both side zippers are secure, zip the rear window zippers down about half way (Fig 27). You will close these zippers completely at the end of step 10.



Each Time you remove the rear window: Completely pull the window out of the "C" Channel before pulling the window down (Fig 27A)!

Do not "Peel" the window out.

NOTICE

There may be times when the "P" extrusion may come out of the "C" Channel ends due to extreme downward pressure. This is normal. If this occurs, slide the "P" extrusion out of the C channel and re-install securing the window back into the "C" Channel.

Step 6: Installing the Top to the Jeep® Body



Starting at the driver's side front, right behind the front seat, attach the front vertical belt rail into the door surround



slot by "rolling" the plastic into the slot (FIGs 28 & 29).



Once secure move to the rear driver's side corner and "roll" the plastic into the Jeep body corner belt rail as shown



in FIGs 30 & 31. Repeat this procedure on the passenger side.



Once both corners are secured, "roll" the plastic on the bottom of the quarter



windows into the body belt rail as shown in FIGs 32 & 33.



NOTE: as shown in FIGs 34 & 35 there is a web loop installed on the side of the quarter window. **This is to be used for unhooking the quarter window only and is not designed to be pulled down on for installation!** Repeat the quarter window install on the passenger side of the vehicle. You may have to pull the corners around towards the front or



back of the vehicle to center the top on the vehicle. Once all body belt rail attachments are secure and the top is centered, you can now reach through the rear zipper on each side and tighten the corner straps. Alternate tightening to keep the top centered. Seal the hook and loop fasteners around the windows.

Step 9: Secure the Over Door Attachments



Locate the two plastic strips sewn to the sides of the top above each door (FIG36).



Starting with the front strips, slip the strips into the channel in the door surround



above the door opening (FIGs 37 & 38). Secure the strips on each side of the



vehicle. When complete each side should look like FIG39.

Step 10: Install the Tailgate Bar and Rear Window to the Jeep® Body



Slide the "C" shaped channel onto the tube sewn into the rear window with the round seal down. See FIG40 for correct alignment. Slide the tailgate bar all the way across the rear curtain.



Open the rear tailgate. As shown in FIG41, insert/roll the tailgate bar into the mounts on each side of the tailgate with the vinyl side of the rear curtain facing the rear of the vehicle.



Once the Tailgate bar is secure, lower zippers on both sides of the rear curtain



(FIG42) and then secure the rear zipper cover flap as shown in FIG43.

Using Your Adventure Top: For Vehicles with Factory installed Fold Back Feature



*Your Quadratec Adventure Top has been designed to work with your factory fold-back sunroof feature. If your soft top hardware has this feature, follow the following instructions: **To fold back your Soft Top:***



If driving, stop the vehicle and put in park.

Unlatch your over door Attachments from the door Surrounds. (FIG44) Unlatch the front header from the windshield (FIG45)



Pushing up from the middle, fold back the front top section. (FIG46)



Make sure the center bow is secured through the sewn inside webbing strap. (FIG47)



Make sure the center bow is secured through the sewn inside webbing strap.

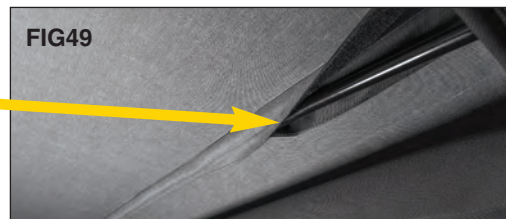

As shown in FIGs 48 & 49.

⚠ WARNING ⚠

MAKE SURE THE HOOK AND LOOP FASTENER ARE TIGHTLY SECURED TO THE CENTER BOW AFTER THE FRONT SUN ROOF IS FOLDED BACK. MAKE SURE THAT EACH SIDE WEBBED LOOP IS SECURED AROUND THE CENTER BOW. BOTH REAR CORNER STRAPS MUST ALSO BE SECURE WHEN THE TOP IS FOLDED BACK THESE SAFETY MEASURES ARE DESIGNED TO SECURE THE TOP DECK TO THE VEHICLE AND IF NOT ADHERED TO CAN CAUSE INJURY, DEATH AND A SERIOUS ACCIDENT.

ALWAYS WEAR YOUR SEAT BELTS WHEN USING THIS PRODUCT!

Care and Maintenance:

Your QuadraTop is made of the finest materials available but to keep it looking new and for the maximum possible wear, it will need periodic cleaning and

basic maintenance. Please see separate insert sheet with our recommendations to prolong the life of your top.

Quadratec® Limited Warranty

for QuadraTop Adventure® Top Premium Replacement Soft Tops

Your QuadraTop® Adventure Top replacement soft top is covered by the following **Limited Warranty** provided exclusively by Quadratec, Inc., 1028 Saunders Lane, West Chester PA 19380.

This Limited Warranty is the only warranty made in connection with your purchase. Quadratec neither assumes nor authorizes any vendor, retailer or other person or entity to assume for it any other obligation or liability in connection with this product or Limited Warranty. This Limited Warranty does not apply and is not cumulative to any accessory or part distributed by Quadratec for which the Manufacturer provides a separate written warranty.

What is Covered: Subject to the terms, exclusions and limitations herein and with respect only to QuadraTop soft tops first sold in the United States, Quadratec warrants to the initial retail purchaser only that your QuadraTop soft top shall be free of defects in material and workmanship: **for a period of 3 years from date of initial retail sale.**

All other warranties are hereby disclaimed, except to the extent prohibited by applicable law in which case any implied warranty of merchantability or fitness for a particular purpose on this product is limited to 3 years from date of initial retail sale. Quadratec reserves the rights to: (a.) require invoice or other proof your soft top is within the terms of this **Limited Warranty** as a condition of warranty service and, (b.) make future revisions to this product and **Limited Warranty** without prior notice or obligation to upgrade your soft top.

What is Not Covered: Your Quadratec **Limited Warranty** does not cover products or parts Quadratec determines to have been damaged by or subjected to: (a.) installation damage, alteration, modification, failure to maintain or attempted repair or service by anyone not authorized by Quadratec, (b.) normal wear and tear, cosmetic damage or damage from water immersion, (c.) Acts of God, accidents, misuse, negligence, inadequate mounting or impact with vehicle(s), obstacles or other aspects of the environment, (d.) theft, vandalism or other intentional damage.

Remedy Limited to Repair/Replacement: The exclusive remedy provided hereunder shall, upon Quadratec inspection and at Quadratec's option, be either repair or replacement of product or parts (new or refurbished) covered under this **Limited Warranty**. Customers requesting warranty consideration on QuadraTop soft top should first contact Quadratec to obtain a RGA number (610-701-3336). All labor, removal, shipping and installation costs are customer's responsibility.

Other Limitations - Exclusion of Damages - Your Rights Under State Law:

In consideration of the purchase price paid, neither Quadratec nor any independent Quadratec distributor/licensee are responsible for any time loss, rental costs, or for any incidental, consequential, punitive or other damages you may have or incur in connection with any part or product purchased. Your exclusive remedy hereunder for covered parts is repair/replacement as described above.

This **Limited Warranty** gives you specific rights. You may also have other rights that vary from state to state. For example, some states do not allow limitations of how long an implied warranty lasts and/or do not allow the exclusion or limitation of incidental or consequential damages, so the limitations and exclusions herein may not apply to you.

©Quadratec, Inc. 2020. All Rights Reserved.
7.8.20 LTR Version Part #12999.3163

The terms Quadratec®, QuadraTop®, Adventure® and Essentials® and are Registered Trademarks of Quadratec Inc. Registered in U.S. Patent and Trademark Office.



Care and Maintenance:

Your QuadraTop is made of the finest materials available but to keep it looking new and for the maximum possible wear, it will need periodic cleaning and basic maintenance. The main threats to your soft top are pollutants, dirt and grime. By keeping your soft top clean you will prolong the life of your top. We recommend the following to keep your top like new:

Washing: The soft top fabric should be washed often using a mild soap, warm water and a soft bristle brush (do not use the brush on the window glass!). You can also use special soft top cleaners available on our website. Make sure that after cleaning you rinse with clear water to remove all traces of soap.

Zippers: Keeping the zipper cleaned and lubricated with a silicone lubricant (#91083.400) will help prevent damage and keep the zippers in a smooth working condition. If zipper opens behind the slider, the slider may have been spread apart. This problem can usually be fixed by using an ordinary pair of pliers to

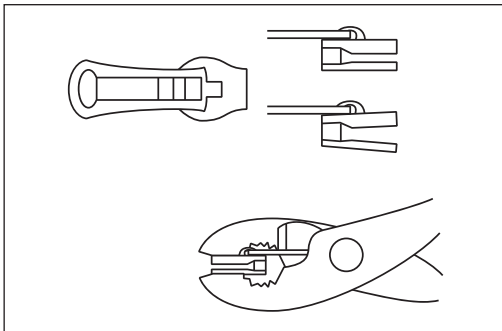

bring the sides back into parallel. Return slider to the end of the zipper in the normal Open position. Squeeze lightly at first and test zipper. If the zipper contin-

ues to remain open squeeze more firmly with pliers and try the zipper again. Repeat procedure until your zipper operates correctly.

Windows: It is very important that you keep your QuadraTop windows clean! Use a mild soap and water solution to gently clean your windows. NEVER wipe your windows clean with a dry cloth! Dust and dirt on a dry cloth can scratch your windows causing "fogging" and permanent damage. When removing your windows, store them with a towel between the panels/rear windows to protect them from damage. If frost or ice forms on the outside of your windows during the winter, DO NOT use an ice scraper to remove this frost. Over time you will see small micro scratches in your windows which are natural wear and tear. These Micro scratches can be "polished" out using the window polish (#91083.000 available at Quadrattec.com).

Water/Fabric: In the event of seeping through the seams, 3M Scotchgard® may be applied on the inside of the seams to stop the see. Rips in the fabric may be repaired with Bondex® iron on patches. Iron the patches to the Inside of the top, carefully following the Bondex® instructions.

Snaps: Keep snaps cleaned and lubricated with silicone to help prevent snaps from sticking to the studs. If a snap does become stuck to a stud, use a screwdriver and GENTLY pry apart to prevent permanent damage to the snap or the top fabric.