

# QuadraTop® Complete Soft Top

for 2018- Current  
4 Door Jeep® Wrangler JLU  
Item #11113.2435



## NOTICE

This Replacement Top kit is designed to fit on your 4 Dr Jeep® Wrangler when the original soft top or hard top has been completely removed. Before beginning your installation of this product, you will need to remove your existing soft top fabric, hardware or Hard top.

Loss of vehicle control involves risk of death or serious injury, particularly to parts of your body not restrained within vehicle. This product is intended for weather protection only and should not be relied upon to contain occupants in the event of an accident or to protect from either ground contact or falling objects. To reduce risk of accident or injury:

## WARNING

- ALWAYS WEAR SEATBELTS
- Always keep head, arms & body parts within vehicle.
- Fully secure or stow the soft top before driving according to instructions. Never try to latch or fold soft top while driving. Do not use if damaged or worn.
- Read and follow all instructions & warnings accompanying this product, in your vehicle owner's manual and Off Road Driving Supplement.

## CAUTION

**RISK OF EYE INJURY.** Safety glasses should be worn at all times while installing or maintaining this product.

### PART LIST:

TOP DECK/HEADER AND REAR BOWS ASSEMBLY	QTY 1
DRIVER SIDE QUARTER WINDOW	QTY 1
PASSENGER SIDE QUARTER WINDOW	QTY 1
REAR WINDOW	QTY 1
CENTER BOW ASSEMBLY	QTY 1
DRIVER SIDE DOOR SURROUND	QTY 1
PASSENGER SIDE DOOR SURROUND	QTY 1
DOOR SURROUND RUBBER	QTY 2
DOOR SURROUND SCREWS	QTY 1
DOOR SURROUND KNOBS	QTY 8
TAILGATE BAR	QTY 2
TAILGATE BAR CORNER MOUNTS	QTY 4
CORNER MOUNTS SHORT KNOBS	QTY 8
REAR BOW SCREWS AND NUTS	QTY 4
REAR BRACKET SCREWS & NUTS	QTY 2
REAR MAIN BRACKET SCREWS AND NUTS	QTY 2
4MM ALLEN WRENCH	QTY 1
REAR MAIN BRACKET SCREW M8	QTY 4
5MM ALLEN WRENCH	QTY 1

### REQUIRED TOOLS:

SAFETY GLASSES  
SOCKET WRENCH  
10MM SOCKET & DRIVER  
PHILLIPS HEAD SCREW DRIVER



The Trusted Source

**Important Safety information**

Your QuadraTop® Complete Soft Top is intended to be used with other Quadra-Top Products to increase the fair weather enjoyment of your off-road capable vehicle. Before installation,

please take a moment to review the following safety information and installation instructions. Important safety information is generally preceded by one of three signal words indicating the relative risk of injury.

The signal words mean.

**WARNING** a hazardous situation which, if not avoided, could result in death or serious injury. You CAN be KILLED or SERIOUSLY HURT if you don't follow instructions.

**CAUTION** a hazardous situation which, if not avoided, could result in minor or moderate injury. You CAN be moderately HURT and also may suffer property damage if you don't follow instructions.

**NOTICE** Careful attention is required to this instruction or operation but does generally not relate to personal injury. Damage to your Quadratec® product or other property may result if you don't follow instructions.

**Before you begin Installation:**

We are excited that you have chosen the QuadraTop Complete Soft Top. This high-quality soft top is designed to provide protection from the elements and a stylish look on your Jeep®.

When unpacking, carefully check to make sure all parts are included. If any part is missing or broken, please call Quadratec customer service at 800-745-6037. Please note that it is important that you become familiar with the installation process of this top by reading the following instruction sheet and warnings thoroughly.

**NOTICE** For a smooth fit and ease of installation, this top should be installed at temperatures above 72 degrees. Below this temperature, the fabric may contract an inch or more making it difficult to install. We highly recommend taking the top out of the package and letting it sit inside a warm place or direct sunlight for 1-2 hours before you install the top. When warm, this top will install quickly.

**Step 1: Un-packing & Organizing the Door Surrounds:**

Put on safety glasses. Carefully remove all the contents of the large shipping box onto a table top or onto the ground on top of a soft towel.

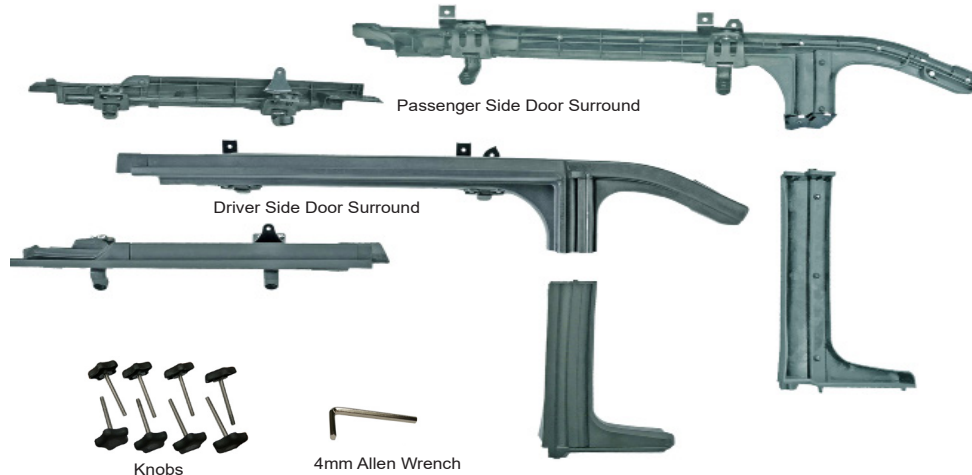

Put your safety Glasses. Carefully remove the contents of each box organizing them as shown in Fig.1 making sure the passenger side and driver's side components are separated.

Once the components are removed from the shipping box, locate the front and rear door surround components and accessories as shown in FIG1.



The Trusted Source

### Step 2: Secure Front Door Surrounds to the Roll Bar

Locate the set of screw knobs and the driver's side front door surrounds (Fig 2). There should be 2 sets of four knobs. See fig 1. These knobs go on the front and rear holes of the brackets.

Line up the front driver's side door surround bracket holes with the vertical holes in the over door horizontal roll bar. Slip the front two knobs through the brackets holes in the front door surround (FIG. 3) lining it up with the hole in the top of the surround bracket on top of the front horizontal roll bar. If you use a rolling motion while you push the brackets, it will be easier to install. Repeat on the passenger side of the vehicle (See note to the right). Loosely tighten each of the knobs securing the front door surround.

FIG 2

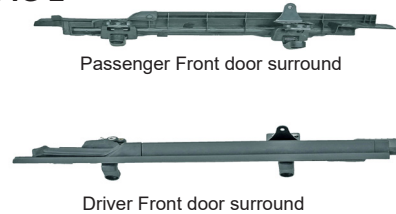

FIG 3



**Note:** if you have difficult lining up the top of the knobs with the upper bracket hole, you can remove the installed top brackets covering the top hole to get a better view of how the screw lines up.

### Step 3: Rear Over Door Surround Assembly

Locate the driver's side rear over door assembly, the driver's side Pillar assembly, the Rubber seal and the 4mm Allen head wrench (Fig 5). On the driver's side rear over door assembly, there are two screws installed for shipping (Fig 6). Remove these screws and set aside. Place the rubber seal on the driver's side pillar assembly (Fig 6A) Line up the Driver side pillar assembly and the driver side rear over door assembly as shown in fig 7. Insert the screws and tighten using the included 4mm Allen wrench securing the two pieces (fig 8)

FIG 5

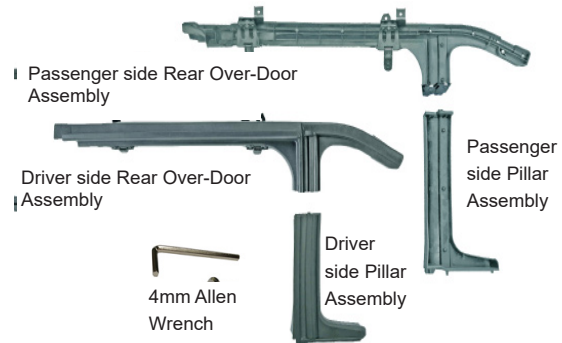

The Trusted Source

**Step 4: Install & Secure Rear Door Surrounds to the Roll Bar**

Locate the assembled Driver's side rear door surround previously installed in step 3.(Fig 9) and a set of screw knobs.

On the bottom of the vertical pillar portion of the assembled door surround are two pins as shown in FIG 10 that will be inserted into the body tub. Insert this pin into the body tub as shown in FIG's 11 & 12. Repeat this procedure on the passenger side rear door surround.

Line up the rear end of the front door surround with the front of the rear door surround as shown in fig 13. Make sure the rear door surround seals are on top of the front Door Surrounds as shown in Fig 13A.

Line up the rear door surround bracket holes with the vertical holes in the rear horizontal roll bar. If you use a rolling motion while you push the brackets on it will be easier to install. Slip the two knobs through the brackets holes in the rear door surround (as you did in step 3). Loosely tighten the knob securing the rear door surround.



**Step 4: Attaching the corner mounts**

Locate the corner mounts and two short knobs (FIG 15). Locate the driver's side corner mount and line up with the corner of the body tub. With the short knob, secure the corner mount to the body tube and tighten. See Fig's 16 & 17

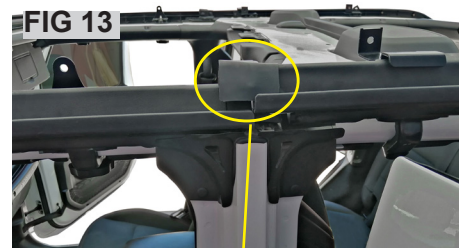
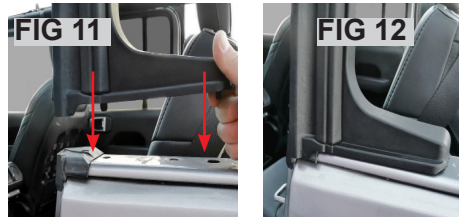
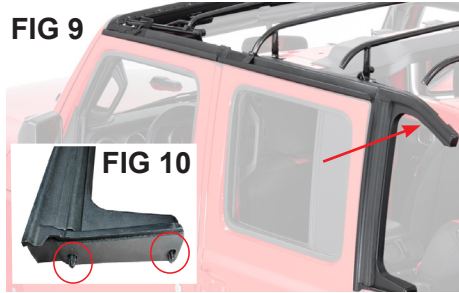

**Note:** if you have difficult lining up the top of the knobs with the upper bracket hole, rotate the bottom of the door surround pin out of the body tub slightly towards you and start the knob. Rotate the pins back into the tub and tighten knob. You can also remove the installed top brackets covering the top hole to get a better view of how the screw lines up. See Fig 14a & 14b.



The Trusted Source



**Step 5: Installing the Center Bow #1 & #2**

Locate the center bow #1 (Fig 18). Each Bow has been labeled to make identification easier. Loosen the screws holding on the top brackets. With the help of a friend, place the Quick release end on the bottom of the bow leg over the second vertical bracket (Fig 19). Pull the quick release knob out and push the bow down mounting the quick release to the bracket. The quick release knob is spring loaded so you should here a “click” when it is secure in the bracket (FIG 19a). Once the bow is installed, tighten the bow mount bracket on the door surround (Fig 20).

**FIG 18**



**FIG 19**



**FIG 20**



**FIG 21**



**FIG 21a**



Repeat this bow mounting on the other side of the vehicle and then repeat the above procedure with center bow #2 (FIG 21). Tighten down the door surround knobs on each side of the vehicle securing the Door surrounds and the two bows.

**Step 7: Installing the rear main bracket to the vehicle**

Locate the driver side rear main bracket (Fig 22).

On the rear sport bar, pull off the plastic cover that comes with the Jeep. there are two metal clips that hold it in place (Fig 23). Line up the driver side rear main bracket over the holes of the sport bar (Fig 24). Locate and insert the included M8 screws and using the included 5mm Allen head tool, tighten the bracket in place (Fig 25). Repeat on the Passenger side using the passenger side rear main bracket.

**FIG 22**

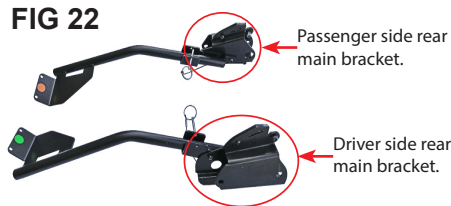

**FIG 23**



**FIG 24**



**FIG 25**



The Trusted Source

**Step 8: Installing the rear bow #1 to the rear leg bracket**

Locate the rear bow #1, (FIG27), and the driver side rear leg bracket #1 (FIG26) installed from factory on the driver side rear main bracket (FIG 22).

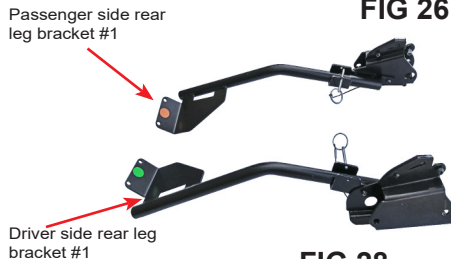

**FIG 26**

There are a pair of screws and nuts installed on the rear leg bracket from factory. Remove these screws and nuts using a 10mm socket wrench and the included 5mm Allen head tool and set aside. (FIG 28)

**FIG 27**



**FIG 28**

Line up the driver's side mounted rear leg #1 to the rear bow #1. Insert the screws and nuts and tighten using the included 4mm Allen as shown in Fig 29.

Fold the Rear Bow #1 and the rear leg #1 to the front (FIG30).

Repeat on the other side of the vehicle

**Step 9: Installing the rear leg #2 to the rear main bracket** In the Driver's side rear main bracket, there is a screw and nut installed from Factory ( Fig 31). Remove this screw and nut, and set aside.

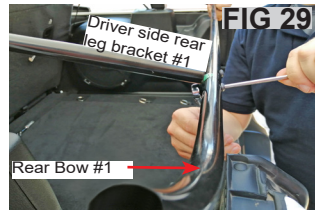

**FIG 29**



**FIG 30**



**FIG 31**

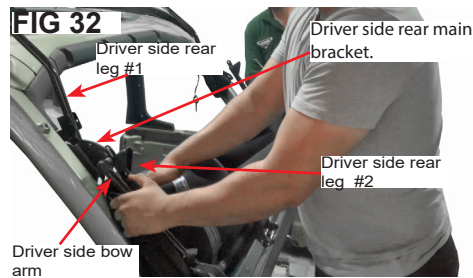

**FIG 32**

With the help of a friend carefully take the top deck assembly out of the box by grasping the rear legs #2 and bow arms that are attached to the front of the windshield header as shown in fig 32 and lay down on the back of the Jeep.

Make sure the holes of the rear leg #2 and main bracket line up (fig 33). Insert the screw and nut previously removed using a 10mm socket and the included 4mm Allen head tool. Tighten and secure the bracket (fig 34 & 35).



**FIG 33**



**FIG 34**

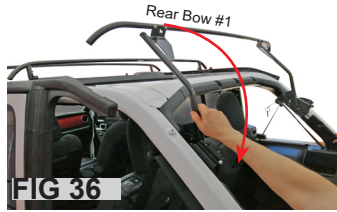

**FIG 35**



The Trusted Source

**Step 10: Hook and Loop Rear bow #1**  
 Fold the Rear Bow #1 and the rear leg #1 to the back (FIG 36).



In the deck there are three flaps sewn to the top deck. Locate the 3rd flap sewn on the deck (FIG 37) and attach the hook and loop around the rear bow #1 as shown in fig 38 & 39.

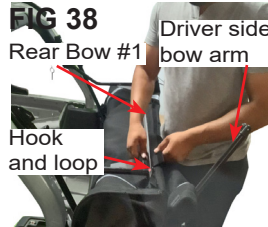

**Step 11: Securing rear bow #1 & rear leg #1**

Once rear bow #1 is secure on the deck, with the help of a friend, fold back to the front, the rear bow #1 and the rear leg #1 (FIG40). Once forward, insert the pin to secure the rear bow as shown in figs 41, 41a & 42

FIG 40



FIG 42

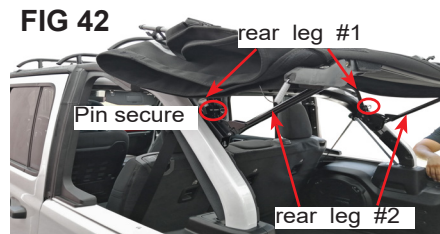

**Step 12: Installing the top Deck**

On the front of the top deck, locate the two bow arms attached to the front windshield header (Fig 43). Pull the front header and top deck fabric to the windshield (FIG 44). Fold back the front header exposing the two bow arm ends.

FIG 43



The bow arms will install to the front bow mount brackets located on the top of the door surrounds. With the help of a friend, lift each of the bow legs over the bow mount bracket (Fig 45).

FIG 44





**Step 12: Installing the top Deck (Continued)**

Once lined up with the bow mount bracket, install the header assembly by pulling out the quick release knob and push over the mount until you hear a “click”(FIG45). Tighten the bow mount brackets on the front door surround with the included 4mm allen wrench (FIG45a). The front header should now easily rest on top of the windshield when folded down.

Repeat on the other side of the vehicle.



Before you fold down the header make sure that the front two header corner pockets are in place and not lifted up over the header (Fig 46). Slowly fold down the front header.

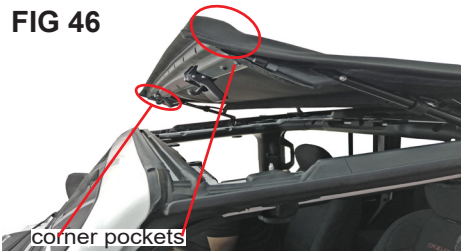

With the header resting on the windshield, close the front header latches to secure the front of the top to the windshield. See FIG's 47 & 48.



Locate the driver side square bracket on the rear driver door surround as shown in Fig 49. Secure the deck to the bracket by rolling the plastic into the slot on the bracket as shown in Fig 50.

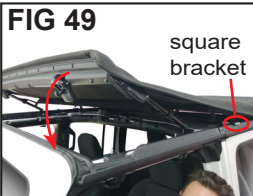

Repeat on the other side of the vehicle.

Go inside the vehicle and locate the front bow, center bow #1 and center bow #2 and the hook and loop laps sewn into the top deck.



Wrap these flaps around the first, second & third center bows securing the top deck to the bows (FIG 54 & 55).



The Trusted Source



**Step 13: Installing the side quarter windows**

Locate the drivers rear quarter window. Line up the driver's side Quarter window to the zipper on the deck and zip it as shown in FIG's 56 & 57

On the rear of the quarter window there is a corner support installed (FIG 58). The quarter window corner support will engage with the plastic corner up in the upper corner the soft top hardware (FIG 59).

Once the upper is secure, in the bottom of the corner support is a tab that rests on top of the corner bracket mount installed in step 5, see Fig 60 & 60a. The corner bracket rests in this tab. Fig 61

FIG 56



FIG 57

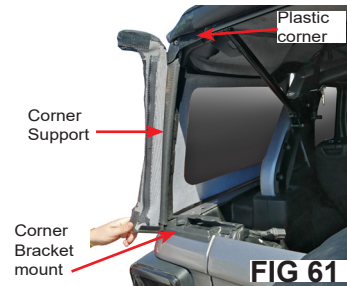
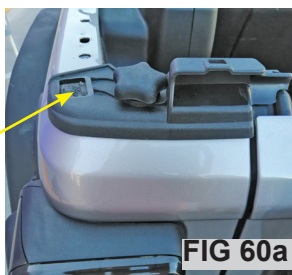

**Step 14: Installing the rear window**

Locate the rear window and line up and slide the rear window into the "C" Channel located at the top of the rear portion of the top deck and slide it across (FIGs 62 & 63).

Once both quarter windows and the upper portion of the rear window are secured to the top deck, line up the driver's side rear zipper on the Quarter window to the zipper on the rear window and zip it down a few inches (FIG 64).

Repeat this on the passenger side of the rear window. You may have to lift the quarter window up to secure this second zipper a few inches. Once both side zippers are attached, zip the rear window zippers down about half way (Fig 65) making sure the top is centered over the rear bow.

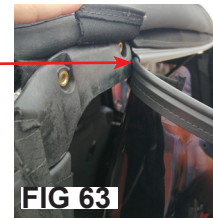

**NOTICE**

When removing the quarter windows from the Top deck, make sure the zipper is completely out of the "zipper box" before removing the window. See fig 66 & 66a

**FIG 66**



**FIG 66a**



**Step 15: Securing the Side and Rear Windows to the Vehicle**

As shown in fig's 67 & 68, roll the vertical plastic strip into the door surround slot securing it to the door surround. Next, starting at the driver's side front, attach the side belt rail into the vehicle body by "rolling" the plastic into the slot (FIG 69 & 70).

**FIG 67**



**FIG 68**



**Note:** You may have to pull the corners around towards the front or back of the vehicle to center the top on the vehicle. If this is too difficult, release the front windshield header latches. Once installed the first time these windows will easily install. Repeat this on the passenger side centering the top over the rear bow.

**FIG 69**



**FIG 70**



**Step 16: Securing the tailgate bar & rear window to the vehicle**

Take the tailgate bar and orient the "C"-Channel with the round seal facing down and slide the "C" Channel onto the rear window retainer as shown in FIG 71 & 72. After sliding the retainer all the way through the "C" Channel, roll the tailgate bar into the mounts with the outside of the fabric facing towards the rear of the Vehicle (Fig 73)

Once the Tailgate bar is secure, lower zippers on both sides of the rear curtain and move to the rear driver's side corner mounts and "roll" the plastic into the corner mount as shown in FIG 74. Repeat this procedure on the passenger side.

**FIG 71**



**FIG 72**

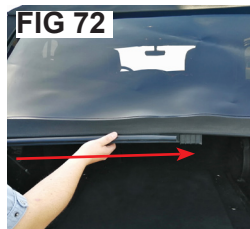

**FIG 73**



**FIG 74**



The Trusted Source

**FIG 75**



**FIG 76**



**FIG 77**



Once the Tailgate bar is secure, Close the hook and loops side flaps (FIG75) and the upper rear flaps (FIG 76 & 77). Then, secure the rear zipper cover flap as shown in Figs 78 & 79. Repeat this procedure on the passenger side.

**FIG 78**



**FIG 79**



**Using Your Complete Soft Top**

Your Soft top hardware has multiple front fold back options. Depending on how much sun and weather you want to let into the cab determines the options available to you

**FIG 80**



**FIG 81**



**Option #1 & #2**

**Open over the front driver and passenger compartments:**

Unlatch the two front Windshield latches (Fig 80 & 81). Push the front header up and over to open the "sunroof". Secure the two side straps. When you open the front portion there will be fabric still hanging down over your head (Fig 82). This is Option #1 which provides protection from the sun while opening the "sunroof". Make sure the two side straps are tightened to the two bows (FIG 82a) on all options.

**FIG 82**

**Partially Open Front**  
(to protect from sun)



**The Trusted Source**



**Using Your Complete Soft Top-  
Continued**

**Option #2 Fully Opened Driver and Passenger Sunroof**

For the next position you will need to slide the two side straps towards the header as shown in fig 83a and push the front bow in the center of the folded back "sunroof" and tuck/ fold it under the header, which opens up the "sunroof" completely (FIG83b). This option is shown in Fig 83.



**Option #3 & #4**

**Open over the front driver and passenger compartments:**

These options open both the front cab and rear cab portions of the top. This option requires you to remove the front header arms and the two bows from the bow mount brackets. Fig 84 shows the finished look of this "Sun Roof" option with the front header installed on the third bow bracket mount and the header folded all the way back to the rear of the vehicle. With the header latches un-latched and front section open, un-hook the 2 quick release knobs located on the end of the header arms as circled in Fig 84a. Next, un-hook the 4 quick release knobs on bow #1 and bow #2 (Fig's 84c, 84d 84e) leaving the two rear bows (Bow #1 & #2) encased in the hook and loop flaps (Fig 84f, 84g). Once The front bow arms and two rear bows are disconnected from the bow mount brackets, with the help of a friend, carefully fold back the front header and two bows layering the top and bows under the fabric (Fig 84f) and then connect the front bow arms quick release brackets to the rear-most third bow mount bracket. This is option # 3. Notice in Fig's.85, 85a & 85b (page 14) how the fabric is "layered" back and the front Bow Mount Brackets are installed to the rear bow brackets.

Also notice in Fig 85a how the side bow straps are pulled up completely towards the front header. This is option #4 with the entire fabric assembly folded back and secured to the rear brackets.

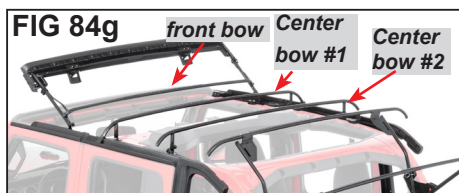

The Trusted Source



The front header arms must be secure to the third bow mount bracket and the fabric/ bows must be layered back before the vehicle is driven! Failure to secure these bow mounts will cause the top to potentially fly off the vehicle causing damage to the top, vehicle and potentially other vehicles on the road.

**WARNING**



**Folding back and securing the entire top to the rear of the vehicle**

To fold back the entire top assembly to the rear of the vehicle and secure, remove the rear and quarter windows from your soft top. Unlatch the quick release knobs (both sides) from the front, Center #1, Center #2 bows (fig 86), unhook the pin securing the rear leg (fig 86a). With the help of a friend, fold back the entire top, folding it under itself to the rear of the vehicle as shown in fig 87. Make sure the front header tubes are secure inside the vehicle and the front header is inside the vehicle. **Important:** Go to page 15 to secure your folded down soft top!

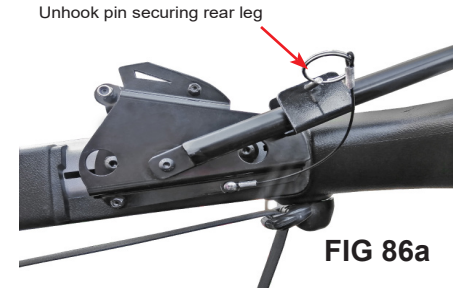
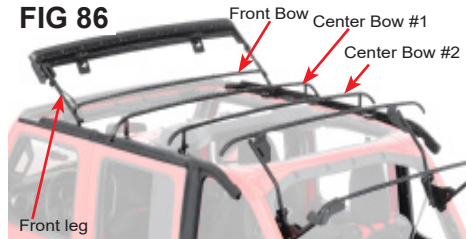

## Using Your Fastback Soft Top Continued

To secure your soft top, locate the two side tension straps (fig 88). Hook the end of strap under the belt rail (fig 89), insert the other side of the tension strap through the strap that is sewn onto the top for shipping located on the front leg, see fig 90. Thread through the buckle and tighten to secure as show in fig 91 & 92. Repeat on the other side of the vehicle.

FIG 88

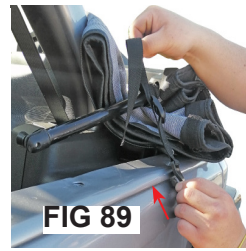

### Threading Straps through Buckles:

For the above strap attachment you will need to thread webbing straps through buckles. Please review the picture to the left for correct strap routing through the buckles. As a rule of thumb, run the strap below and through the sewn side of the buckle first and then back down through the end of the buckle. Tighten the strap by simply pulling the exposed webbing after threading the strap through the buckle.

### WARNING

When folding back your soft top, it must always be secured to the vehicle using the enclosed straps shown above. When the Top is folded back in the sun roof position, make sure the quick release knobs are secure. Failure to do so may result in damage to your vehicle, hardware system, soft top and your person.



The Trusted Source



### Care and Maintenance:

Your QuadraTop is made of the finest materials available but to keep it looking new and for the maximum possible wear, it will need periodic cleaning and basic maintenance. The main threats to your soft top are pollutants, dirt and grime. By keeping your soft top clean you will prolong the life of your top. We recommend the following to keep your top like new:

**Washing:** The soft top fabric should be washed often using a mild soap, warm water and a soft bristle brush (do not use the brush on the window glass!). You can also use special soft top cleaners available on our website and shown on page 15. Make sure that after cleaning you rinse with clear water to remove all traces of soap.

**Zippers:** Keeping the zipper cleaned and lubricated with a silicone lubricant (see Page 15) will help prevent damage and keep the zippers in a smooth working condition. If zipper opens behind the slider, the slider may have been spread apart. This problem can usually be fixed

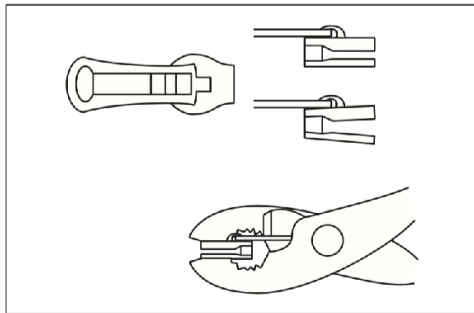

by using an ordinary pair of pliers to bring the sides back into parallel. Return slider to the end of the zipper in the normal Open position. Squeeze lightly at first and test zipper. If the zipper continues to remain open squeeze more firmly with pliers and try the zipper again. Repeat procedure until your zipper operates correctly.

**Windows:** It is very important that you keep your QuadraTop windows clean! Use a mild soap and water solution to gently clean your windows. NEVER wipe your windows clean with a dry cloth! Dust and dirt on a dry cloth can scratch your windows causing "fogging" and permanent damage. When removing your windows, store them with a towel between the panels/rear windows to protect them from damage. If frost or ice forms on the outside of your windows during the winter, DO NOT use an ice scraper to remove this frost. Over time you will see small micro scratches in your windows which are natural wear and tear. These Micro scratches can be "polished" out using the window polish listed on page 15 (Available at Quadratec.com).

**Water/Fabric:** In the event of seeping through the seams, 3M Scotchgard® may be applied on the inside of the seams to stop the see. Rips in the fabric may be repaired with Bondex® iron on patches. Iron the patches to the Inside of the top, carefully following the Bondex® instructions.

**Snaps:** Keep snaps cleaned and lubricated with silicone to help prevent snaps from sticking to the studs. If a snap does become stuck to a stud, use a screwdriver and GENTLY pry apart to prevent permanent damage to the snap or the top fabric.



The Trusted Source

# Quadratec Limited Warranty

## for QuadraTop® Replacement Soft Tops

Your QuadraTop® replacement soft top is covered by the following Limited Warranty provided exclusively by Quadratec, Inc. 1028 Saunders Lane, West Chester, PA 19380.

This **Limited Warranty** is the only warranty made in connection with purchase. Quadratec neither assumes nor authorizes any vendor, retailer or other person or entity to assume for it any other obligation or liability in connection with this product or **Limited Warranty**.

### **What is Covered:**

Subject to the terms, exclusions and limitations herein and with respect only to soft tops first sold in the United States, Quadratec warrants to the initial retail purchaser only that your QuadraTop soft top shall be free of defects in material and workmanship for a **period of 3 years from date of initial retail sale**.

All other warranties are hereby disclaimed, except to the extent prohibited by applicable law in which case any implied warranty of merchantability or fitness for a particular purpose on this product is limited to 3 years from date of initial retail sale. Quadratec reserves the rights to: (a.) require invoice or other proof your soft top is within the terms of this **Limited Warranty** as a condition of warranty service and, (b.) make future revisions to this product and **Limited Warranty** without prior notice or obligation to upgrade your soft top.

### **What is Not Covered:**

Your Quadratec **Limited Warranty** does not cover products or parts Quadratec determines to have been damaged by or subjected to: (a.) installation damage, alteration, modification, failure to maintain or attempted repair or service by anyone not authorized by Quadratec, (b.) normal wear and tear, cosmetic damage or damage from water immersion, (c.) Acts of God, accidents, misuse, negligence, inadequate mounting or impact with vehicle(s), obstacles or other aspects of the environment, (d.) theft, vandalism or other intentional damage.

**Remedy Limited to Repair/Replacement:** The exclusive remedy provided hereunder shall, upon Quadratec inspection and at Quadratec's option, be either repair or replacement of product or parts (new or refurbished) covered under this **Limited Warranty**. Customers requesting warranty consideration on QuadraTop soft top should first contact Quadratec to obtain a RGA number (610-701-3336). All labor, removal, shipping and installation costs are customer's responsibility.

### **Other Limitations - Exclusion of Damages - Your Rights Under State Law:**

In consideration of the purchase price paid, neither Quadratec nor any independent Quadratec distributor/licensee are responsible for any time loss, rental costs, or for any incidental, consequential, punitive or other damages you may have or incur in connection with any part or product purchased. Your exclusive remedy hereunder for covered parts is repair/replacement as described above.

This **Limited Warranty** gives you specific rights. You may also have other rights that vary from state to state. For example, some states do not allow limitations of how long an implied warranty lasts and/or do not allow the exclusion or limitation of incidental or consequential damages, so the limitations and exclusions herein may not apply to you.

The terms Quadratec®, QuadraTop® Essentials® and Essential® are Registered Trademarks of Quadratec Inc. Registered in U.S. Patent and Trademark Office.

©Quadratec, Inc. 2023. All Rights Reserved. Version 8.28.23

Part # 941048.01



The Trusted Source