



RHINO-RACK

PIONEER ALLOY TRAY (flat pack)

Important:

1. Check the Rhino-Rack website to ensure you have the latest issue of these instructions.
2. Please refer to your fitting instruction to ensure that the roof racks are installed in the correct locations.
3. Check the contents of kit before commencing fitment and report any discrepancies.
4. Place these instructions in the vehicle's glove box after installation is complete.
5. These instructions must be followed for warranty to be upheld.

Fit Time: 1 hour



rhinorack.page.
link/FitMyCar

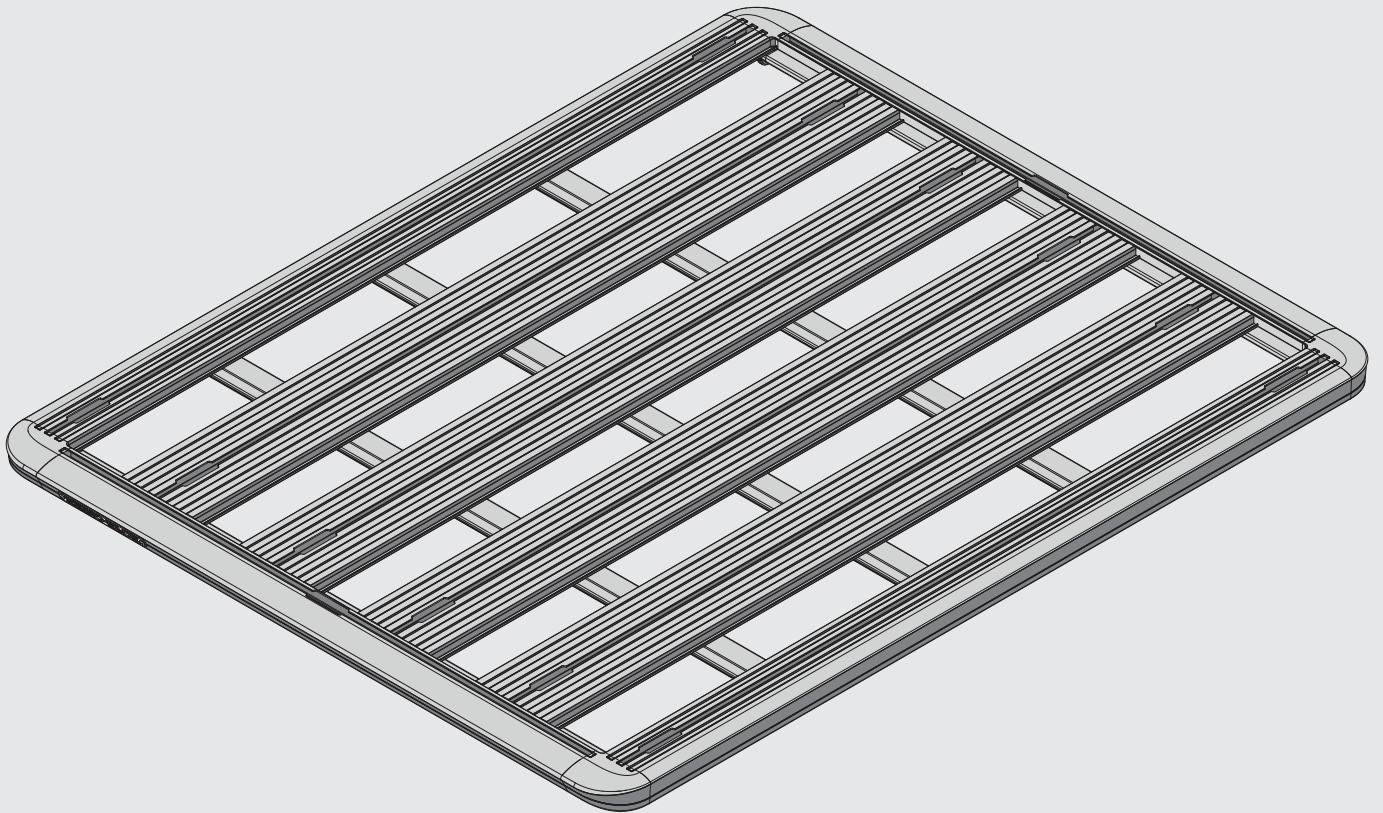

Instructions - Instrucciones

Carrying Capacity

Max system load capacity (incl. system weight), refer to Pioneer fit sheet.

Check your vehicle owners hand book for vehicle maximum carrying capacity. Please ensure you use the vehicle manufacturers maximum roof allowance if it is lower than the figure listed in this instruction. Load must be evenly distributed over the system.

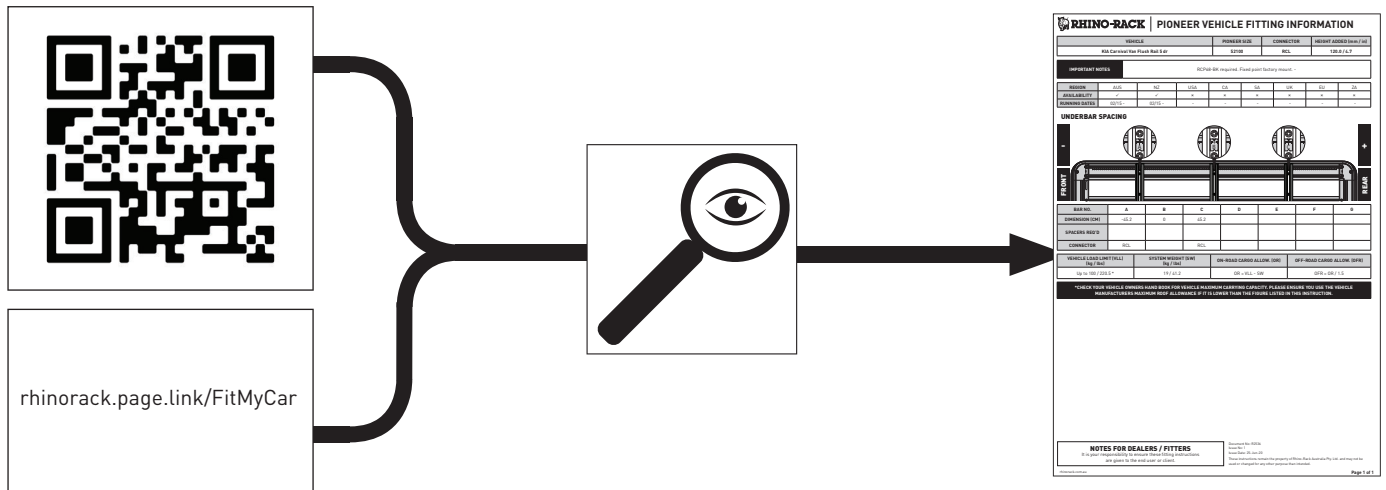

Off Road: Any driven path taken that does not contain a surface protection layer (tar/bitumen).

Vehicle Load Limit: Total permissible weight attached to the roof of the car. This is inclusive of the weight of the roof rack system.

System Load Limit: Total permissible weight allowed on top, and attached to roof racks whilst the vehicle is in motion.

Torque Settings

Unless stated otherwise in these instructions, all fasteners should be set to the following torque settings - M6: 4-5Nm (3-4lbs/ft), M8: 8-10Nm (6-7.5lbs/ft) and M10: 16-18Nm (12-13lbs/ft).

Warning

- Check part number/ or kit is correct for use with your vehicle.
- Do not attempt to fit the rack system to your vehicle unless you fully understand these fitting instructions. Please direct any questions regarding fitting to the dealer from where the roof racks were purchased.
- Although the system is tested and approved to AS1235-2000 / ISO 11154, off-road conditions can be much more rigorous. Extreme care must be taken in off road conditions.
- Roof racks must be removed when vehicle is put through an automatic car wash.
- With utility vehicles, the cabin and the canopy move independently. Roof racks and vehicle can be damaged if the item transported is rigidly fixed at points on both the cabin and canopy. Instead, rigidly fix to either the cabin roof racks or the canopy roof racks.
- Always ensure you fasten your load securely.
- Use only non-stretch fastening ropes or straps to attach cargo to your load.

In service maintenance checks

- All bolted connections should be checked after driving a short distance when you first install your roof racks.
- All bolted connections should be checked again at regular intervals (weekly is recommended, depending on road conditions, usage, loads and distances travelled).
- All bolted connections should be checked each time they are re-fitted.

Note for Dealers and Fitters

It is your responsibility to ensure these fitting instructions are given to the end user or client. These instructions remain the property of Rhino-Rack Australia Pty. Ltd. and may not be used or changed for any other purpose than intended.

Instructions - Instrucciones

Capacidad de Carga

Capacidad máxima de carga para el Sistema (incluye el Sistema de peso). Revise el manual del propietario de su vehículo para la capacidad máxima de carga. Por favor asegúrese de solo usar la cantidad máxima de carga para el techo permitida por el fabricante, si es menor que lo enlistado en la siguiente tabla. La carga debe de ser distribuida equivalentemente sobre el Sistema.

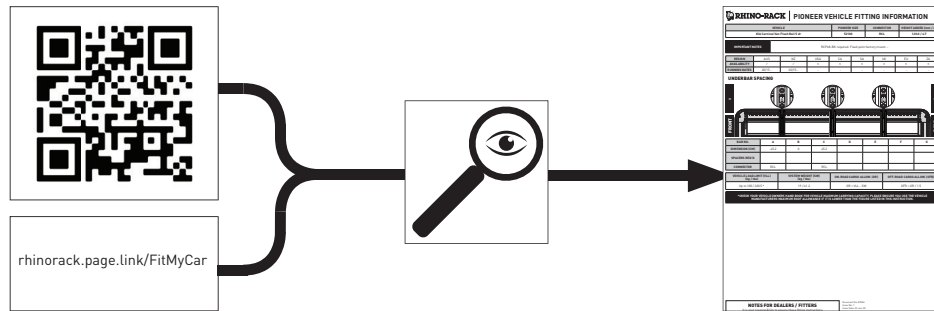

Terracería: Cualquier camino en donde se pueda manejar que no contenga una capa protectora en la superficie (alquitrán/betún/pavimento).

Límite de carga del vehículo: Peso total permisible agregado a el techo del vehículo (esto incluye el peso del sistema de las barras del techo).

Límite de carga del sistema: Peso total permisible permitido en el techo, agregado a las barras del techo mientras el vehículo está en movimiento.

Configuración de esfuerzo de torsión:

A menos de que este escrito lo contrario en estas instrucciones, todos los sujetadores debenser configurados con las siguientes instrucciones

M6: 4-5Nm (3-4 lbs/ft)

M8: 8-10Nm (6-7.5 lbs/ft) y

M10: 16-18 Nm (12-13 lbs/ft)

Precaución

- Asegurarse que el número de parte/equipo es el correcto para usarse en su vehículo.
- No intente instalar el equipo de barras de techo en su vehículo a menos que entienda completamente las instrucciones de instalación. Por favor dirija cualquier pregunta relacionada con la instalación a el vendedor autorizado en donde adquirió el equipo.
- A pesar de que el sistema ha sido examinado y aprobado por AS1235-2000/ISO 11154, las condiciones de terracería pueden ser mucho más rigurosas. Se debe tener extremo cuidado en las condiciones de la terracería.
- Las barras del techo deben ser removidas antes de que el vehículo entre en un sistema de auto-lavado.
- En vehículos de utilería, la cabina y la cubierta de el vehículo se mueven independientemente. Las barras del techo y el vehículo pueden ser dañados si el artículo que se está transportando esta rígidamente fijo en los puntos de ambos cabina y cubierta. En lugar, se debe fijar solamente a uno de los dos (cabina o cubierta).
- Siempre asegúrese que sujetar su carga de forma segura.
- Solamente debe de usar sujetadores no elásticos para asegurar su carga a las barras del techo.

Revisiones de mantenimiento de servicio:

- Todas las conexiones de tornillos deben ser revisadas después de manejar una corta distancia cuando se instala por primera vez las barras del techo.
- Todas las conexiones con tornillos deben ser revisadas nuevamente en intervalos regulares (se recomienda semanalmente, dependiendo de las condiciones del camino, el uso, las cargas y las distancias recorridas).
- Todas las conexiones con tornillos deben ser revisadas cada vez que se reparan.

Nota para Vendedores e Instaladores:

- Es su responsabilidad asegurarse que las instrucciones de instalación sean dadas a el cliente o quien reciba el producto. Estas instrucciones son propiedad.

Instructions - Instrucciones

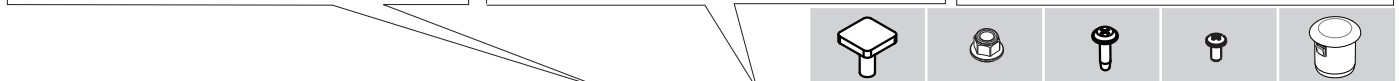
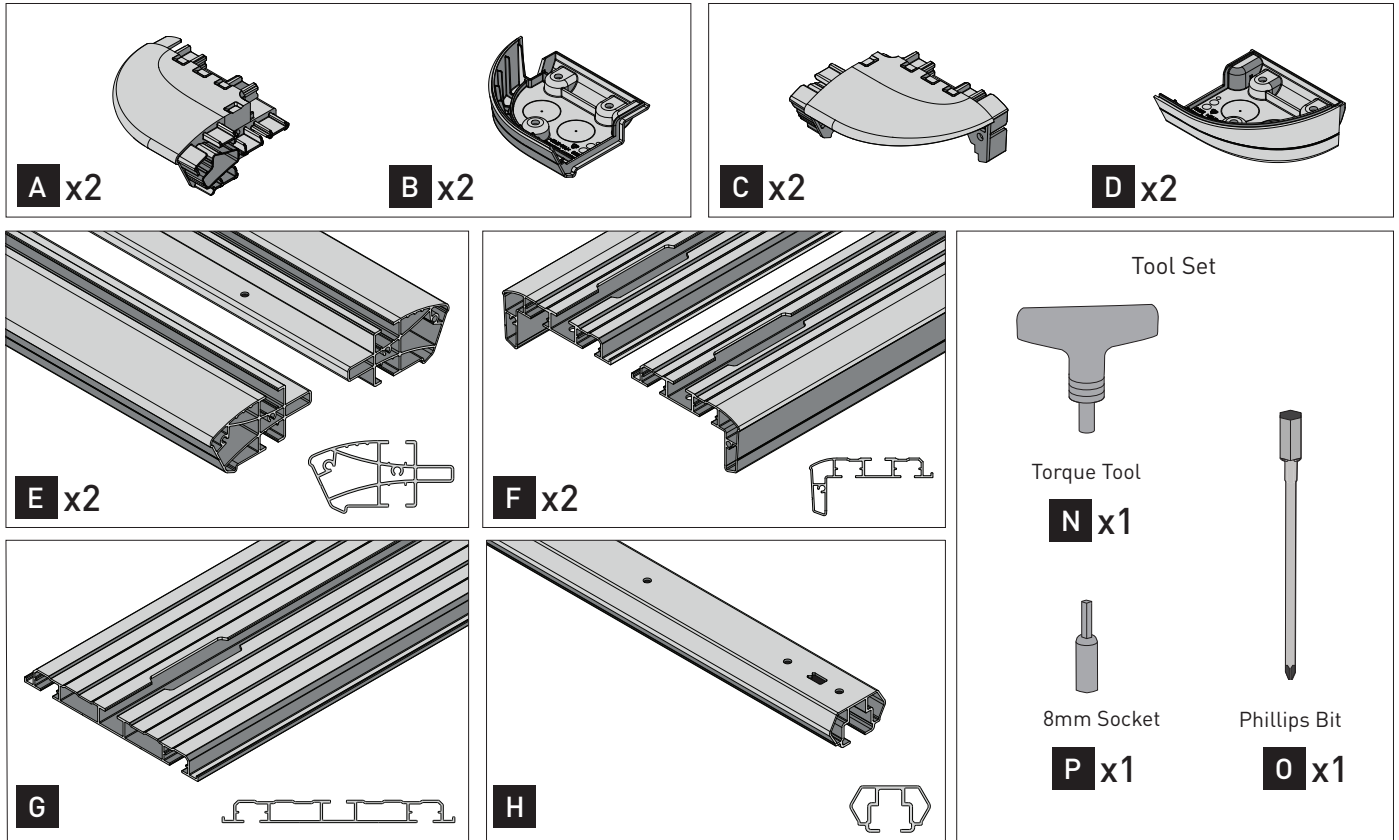

Platform #	L x W (mm)	L x W (inches)	G	H	I	J	K	L	M
52100	1528 x 1236	60' x 49'	4	3	52	52	12	16	6
52101	1528 x 1376	60' x 54'	5	3	62	62	12	16	6
52102	1928 x 1236	76' x 49'	4	5	76	76	12	16	6
52103	1928 x 1376	76' x 54'	5	5	90	90	12	16	6
52104	2128 x 1426	84' x 56'	5	5	90	90	12	16	N/A
52105	2728 x 1465	107' x 58'	5	6	104	104	12	16	N/A
52107	2128 x 1236	84' x 49'	4	5	76	76	12	16	N/A
52108	1828 x 1426	72' x 56'	5	5	90	90	12	16	N/A
52109	1328 x 1236	52' x 49'	4	3	52	52	12	16	N/A
52110	1328 x 1376	52' x 54'	5	3	62	62	12	16	N/A
52111	1328 x 1426	52' x 56'	5	3	62	62	12	16	N/A
52112	928 x 1426	37' x 56'	5	2	48	48	12	16	N/A
52113	1528 x 1426	60' x 56'	5	5	90	90	12	16	N/A
52114	1228 x 952	48' x 37'	3	1	22	22	12	16	N/A
52115	1478 x 1184	58' x 47'	4	1	28	28	12	16	N/A
52119	2528 x 1586	100' x 62'	5	6	104	104	12	16	N/A
52120	1528 x 1586	60' x 62'	5	3	62	62	12	16	N/A
52121	1228 x 1426	48' x 56'	5	3	62	62	12	16	N/A

Tools required:

Herramientas necesarias:

- T1 - Phillips head screwdriver.
- T2 - Power drill.

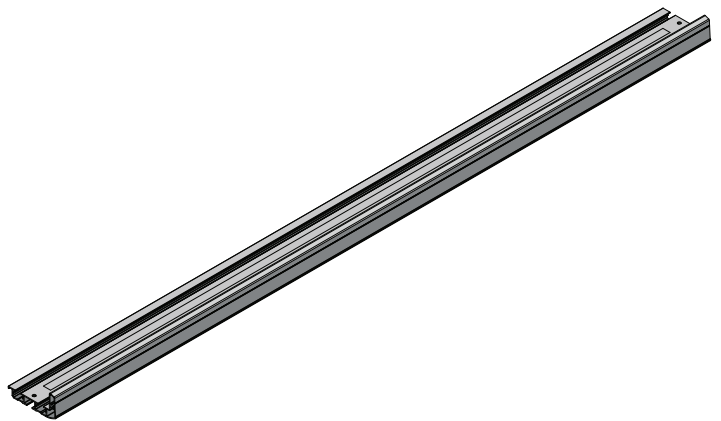
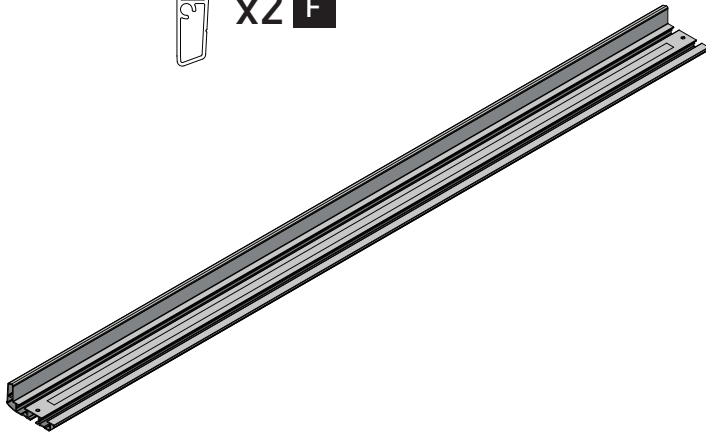
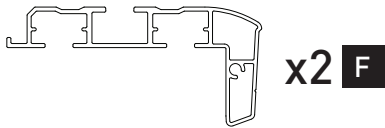

1

✓

✗

H x3 = **I** x12

H x4 = **I** x16

H x5 = **I** x20

H x6 = **I** x24

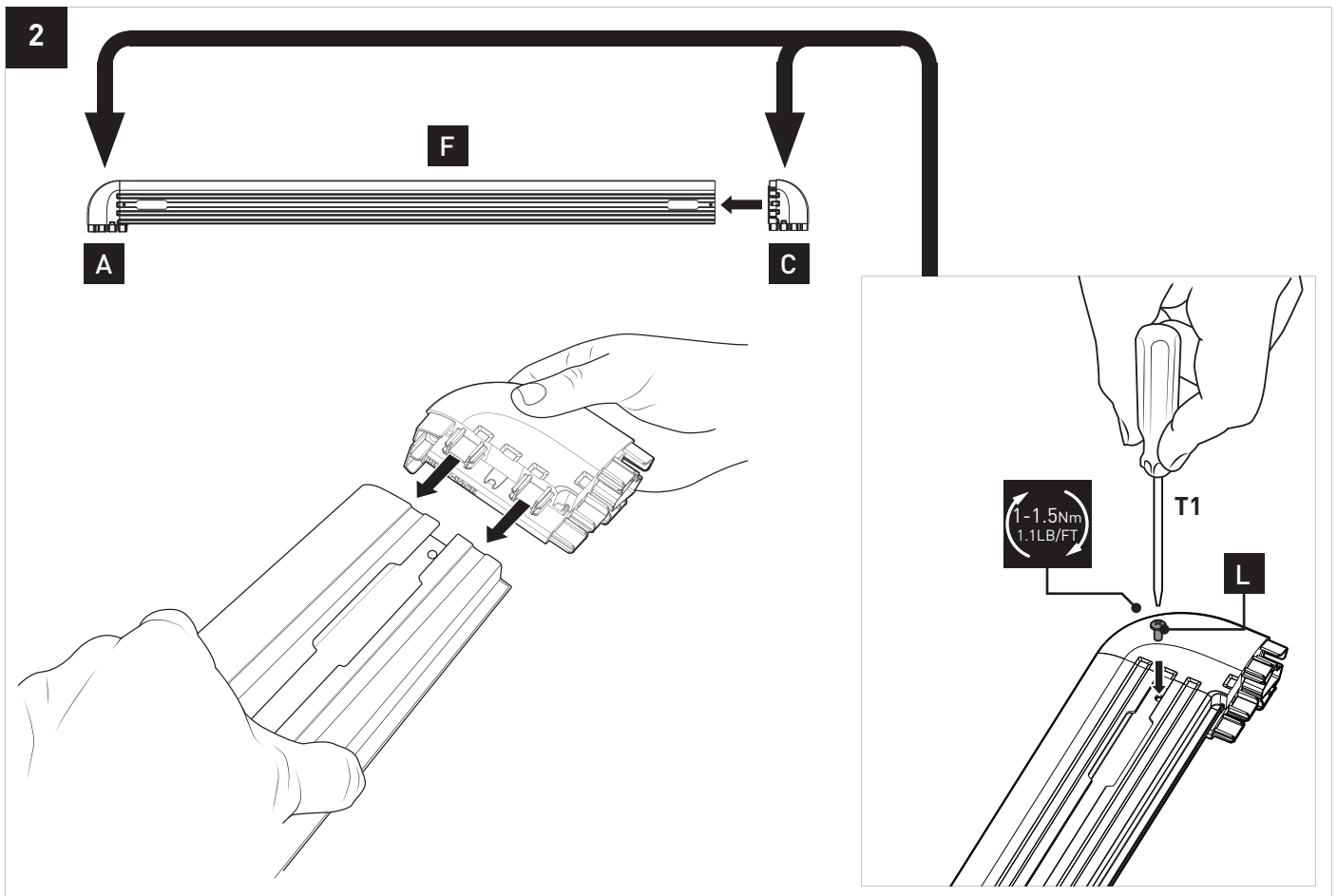
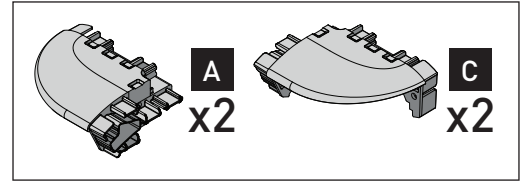

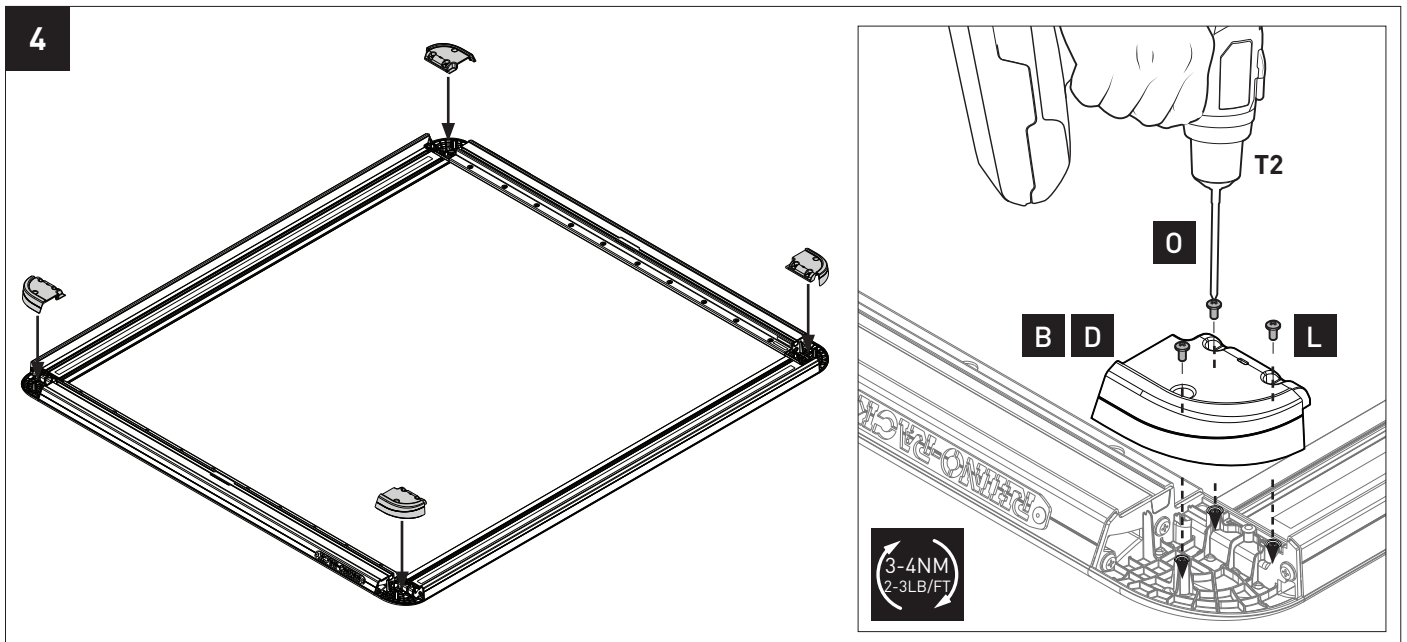
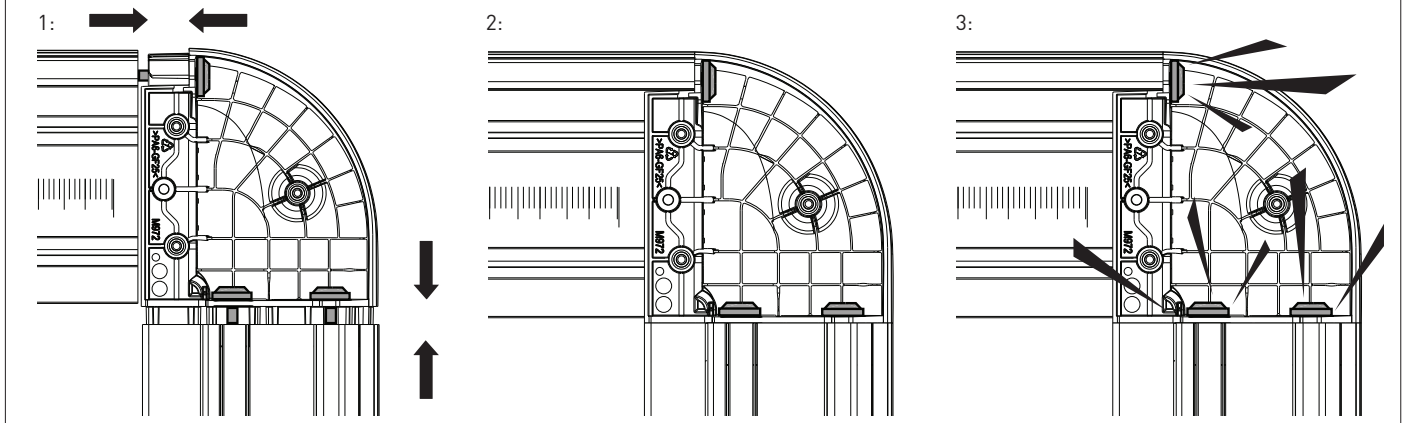
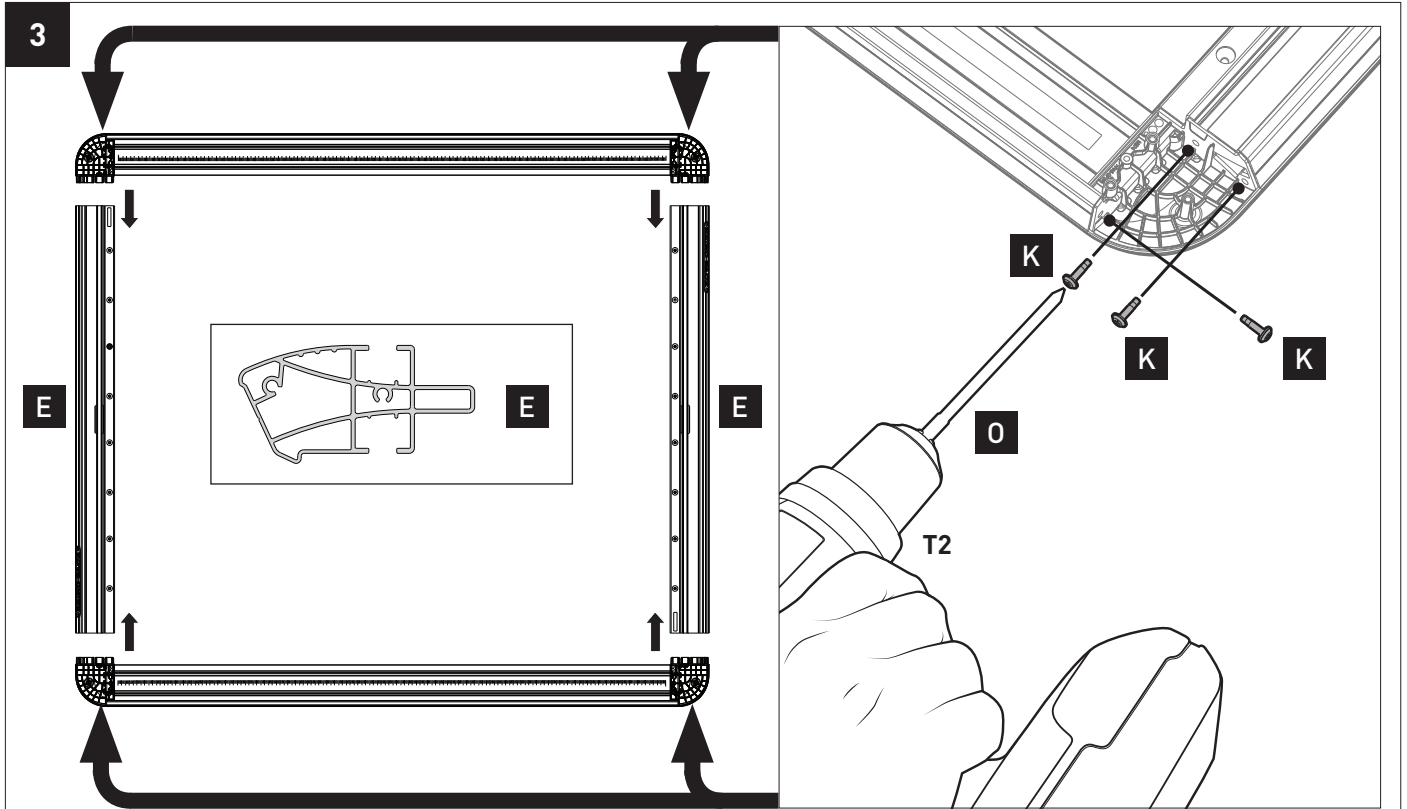

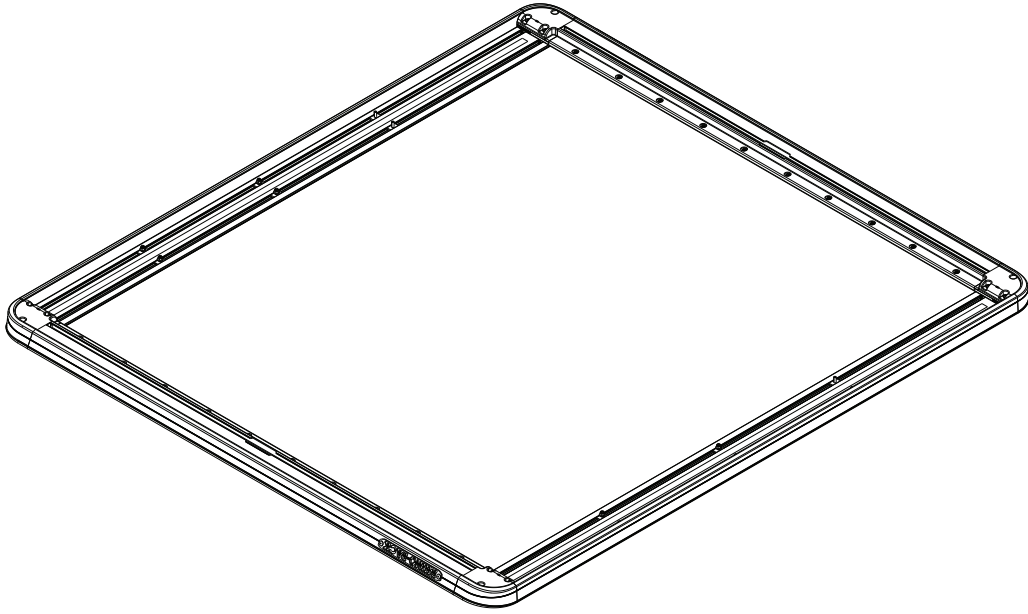

5

<p>E x3 + H x10 = I x10</p>	<p>E x4 + H x12 = I x12</p>	<p>E x5 + H x14 = I x14</p>	<p>E x6 + H x16 = I x16</p>
<p>I</p> <p>G</p>	<p>I</p> <p>G</p>	<p>I</p> <p>G</p>	<p>I</p> <p>G</p>

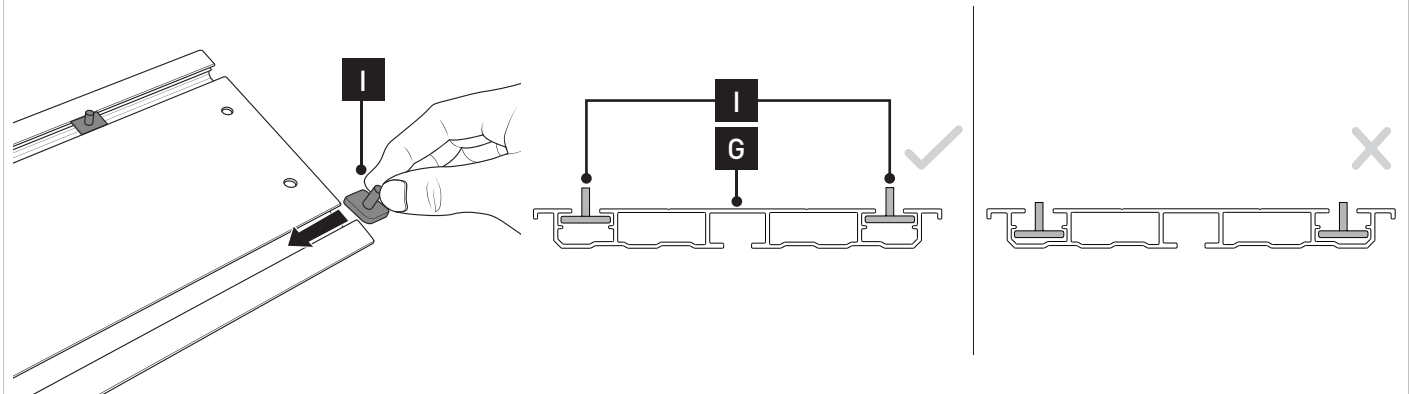

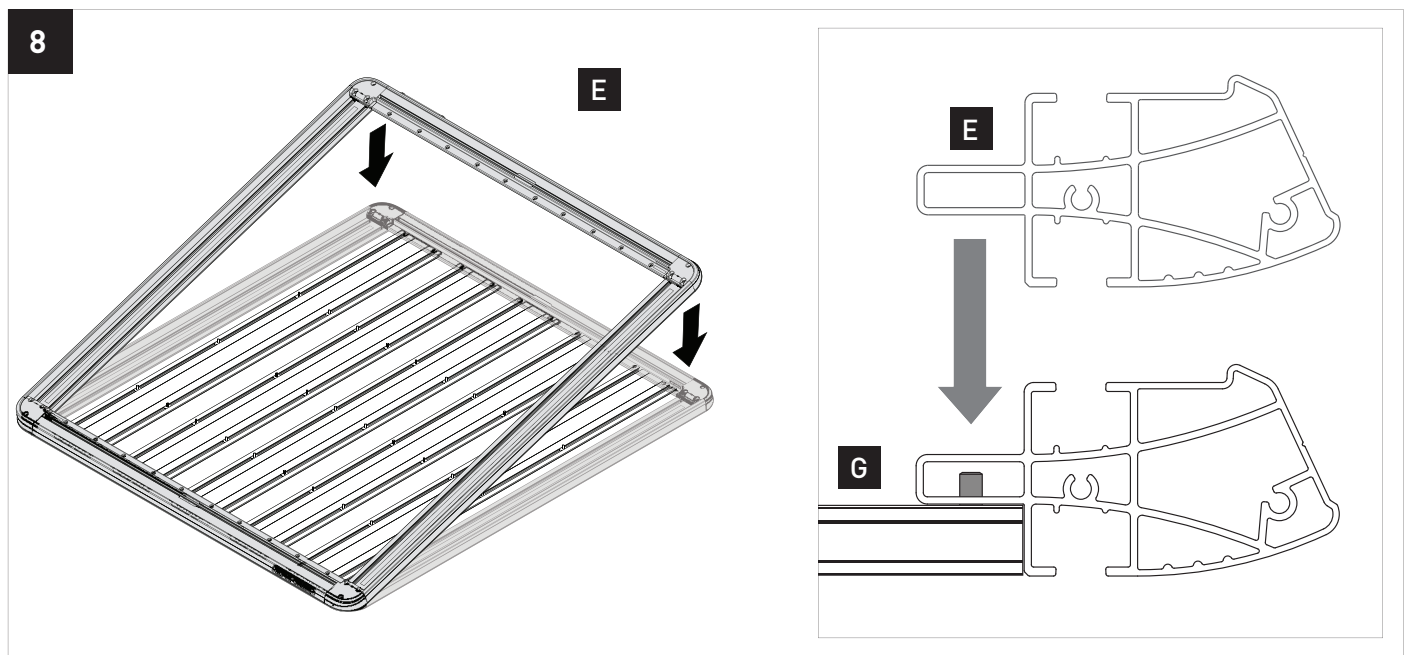
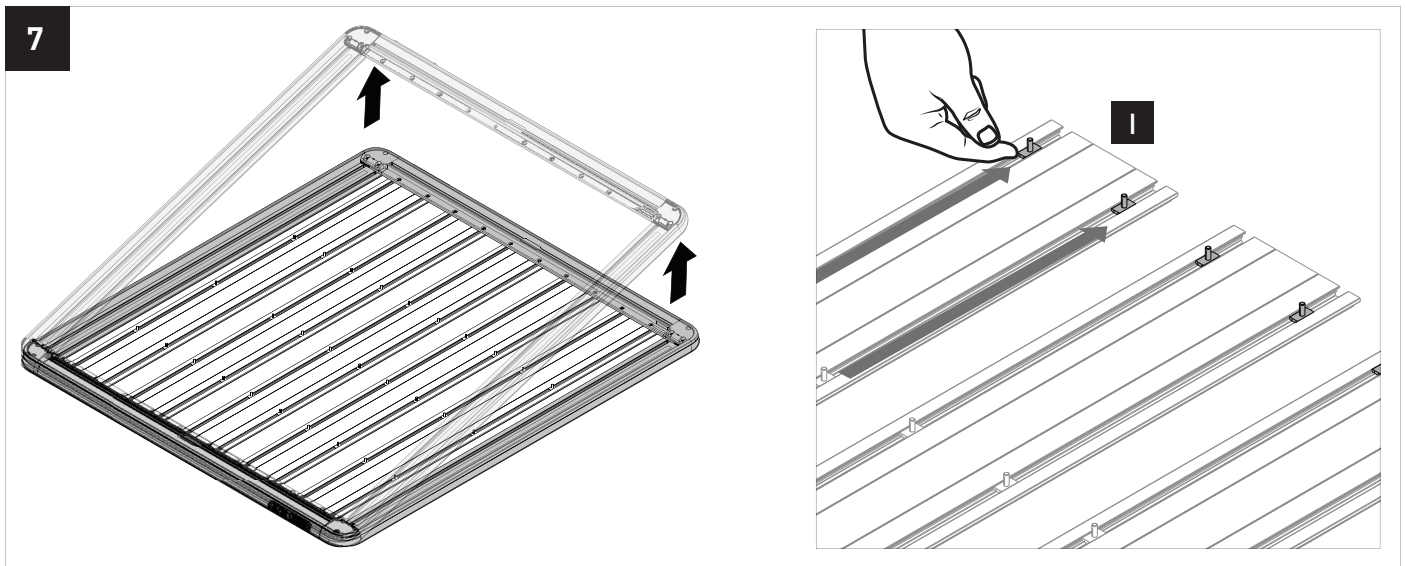
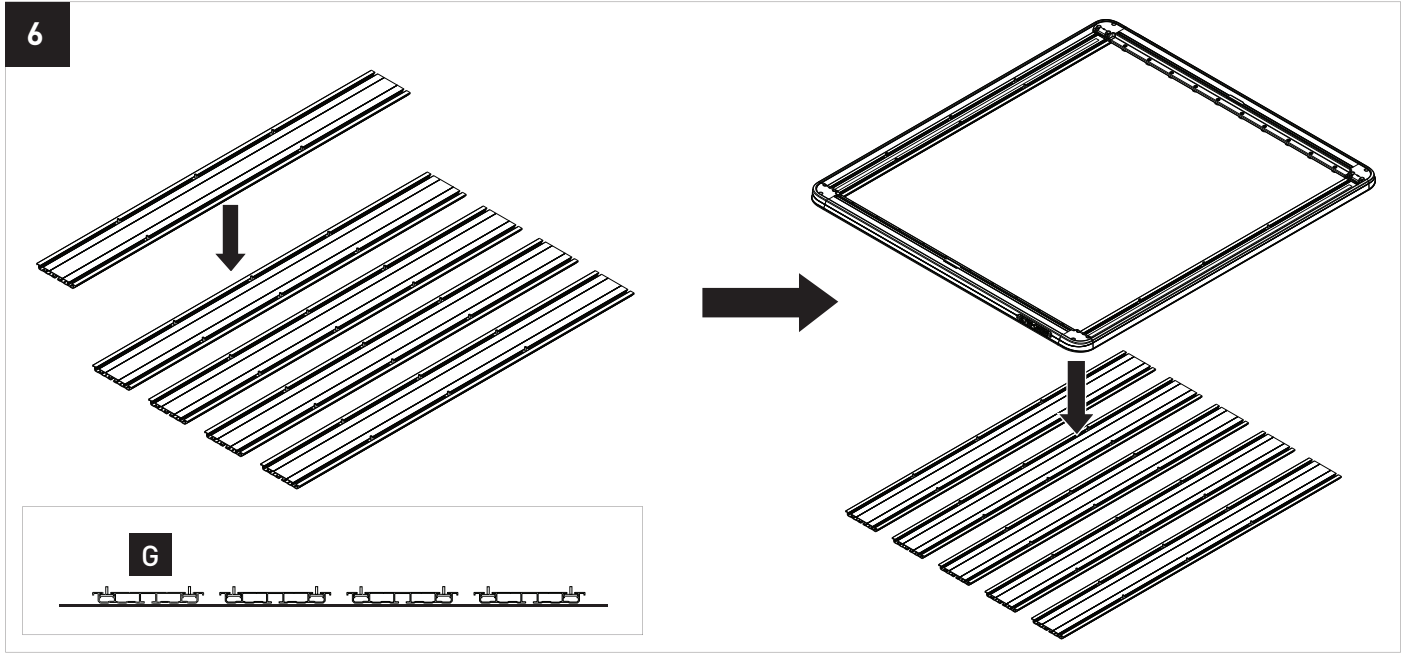

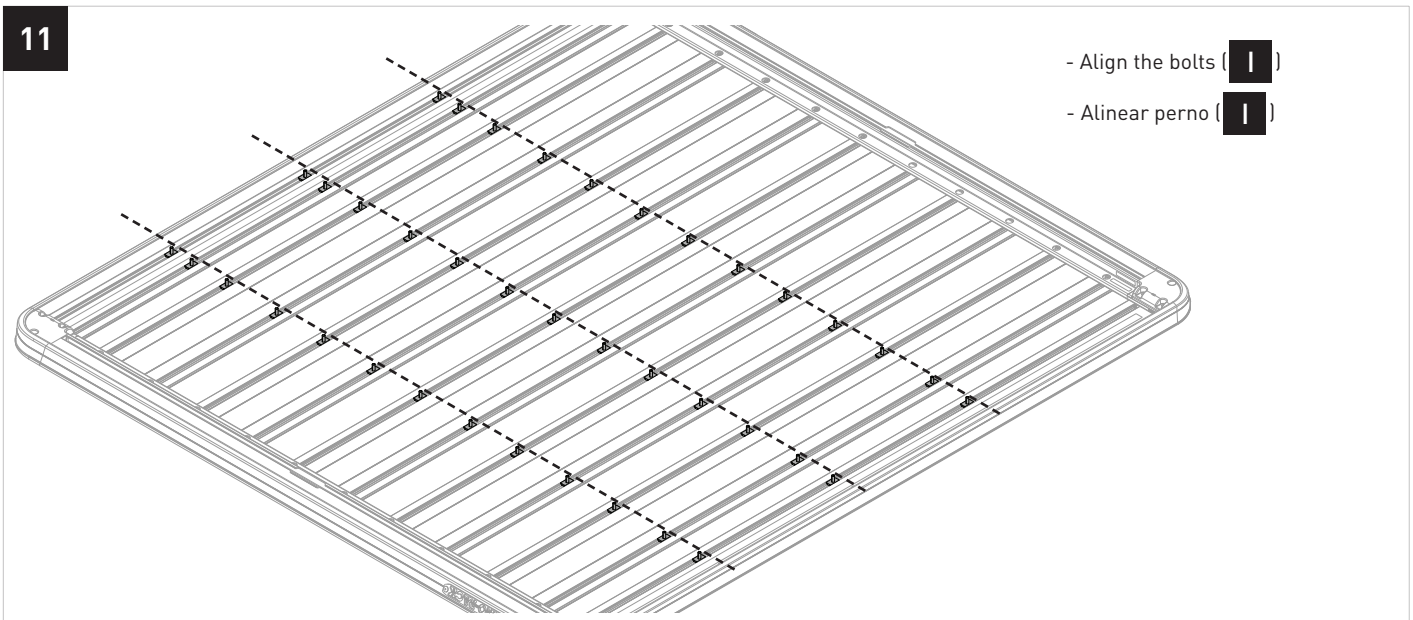
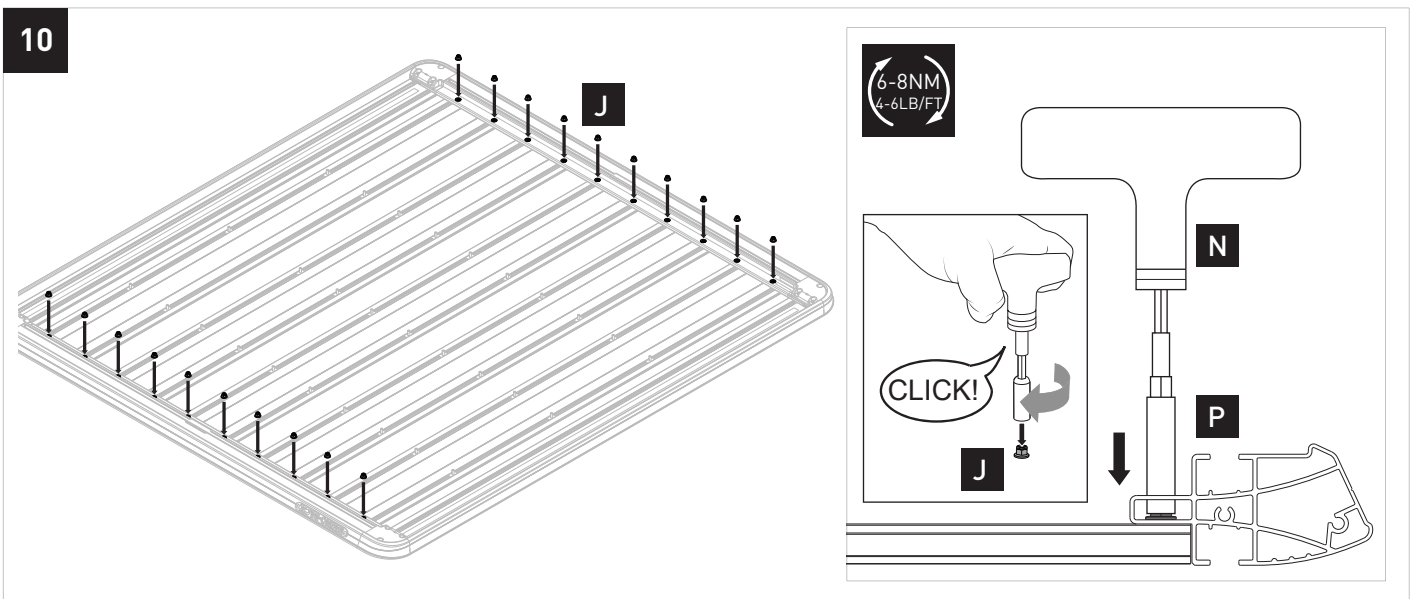
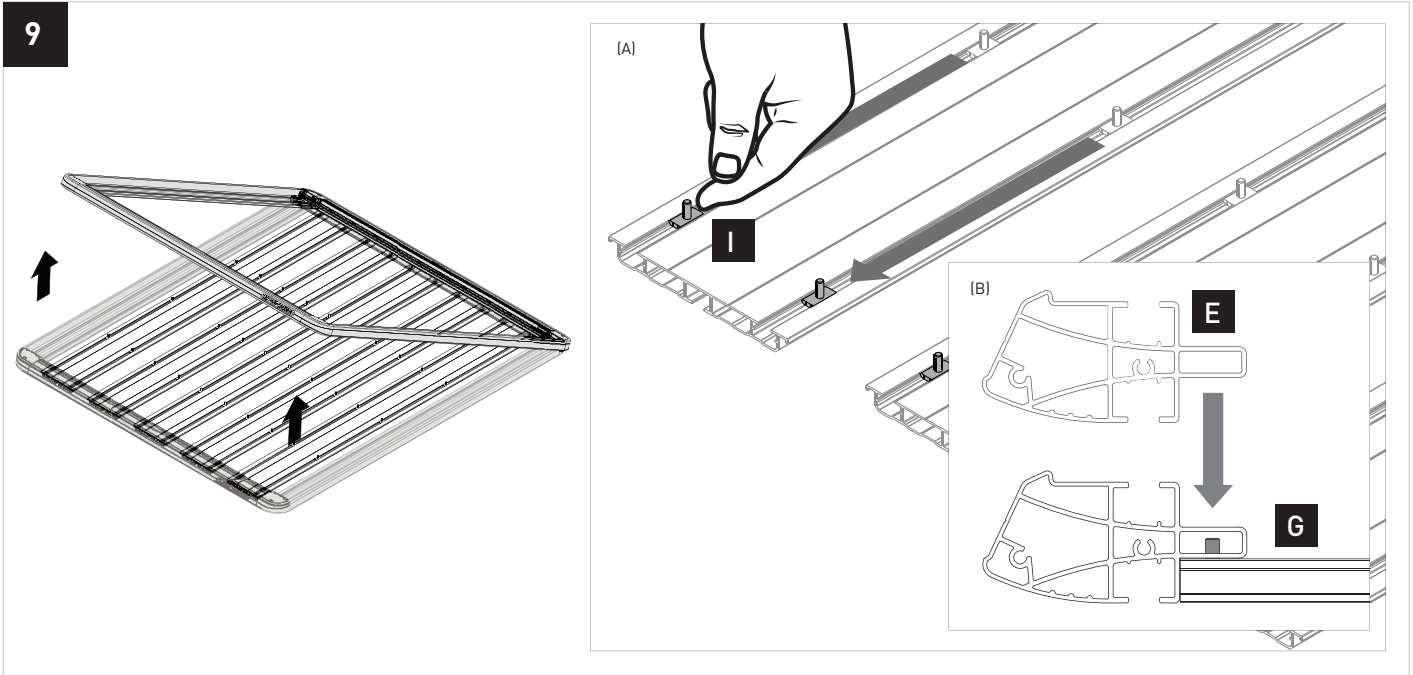

12

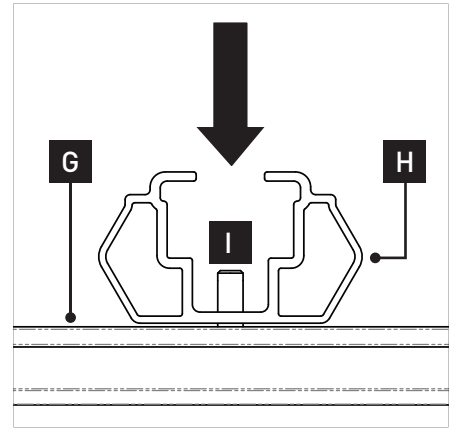
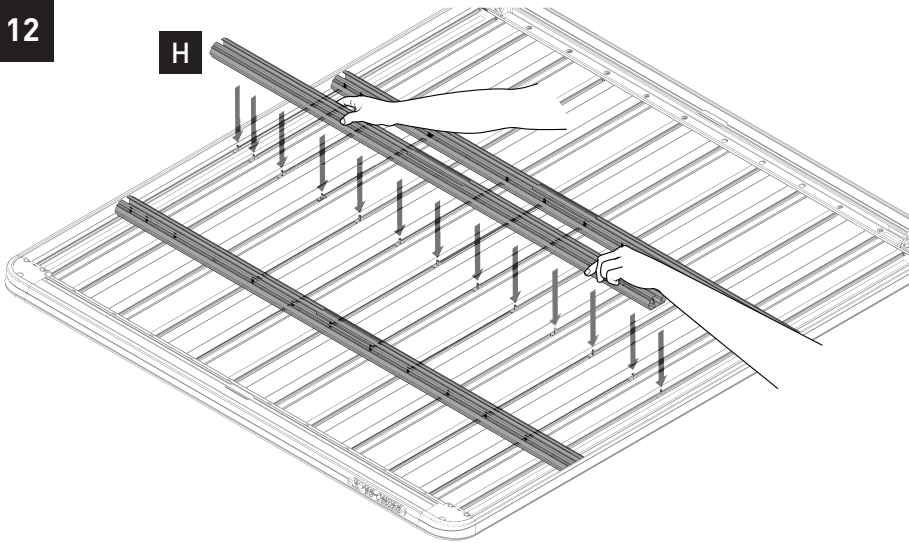

13a

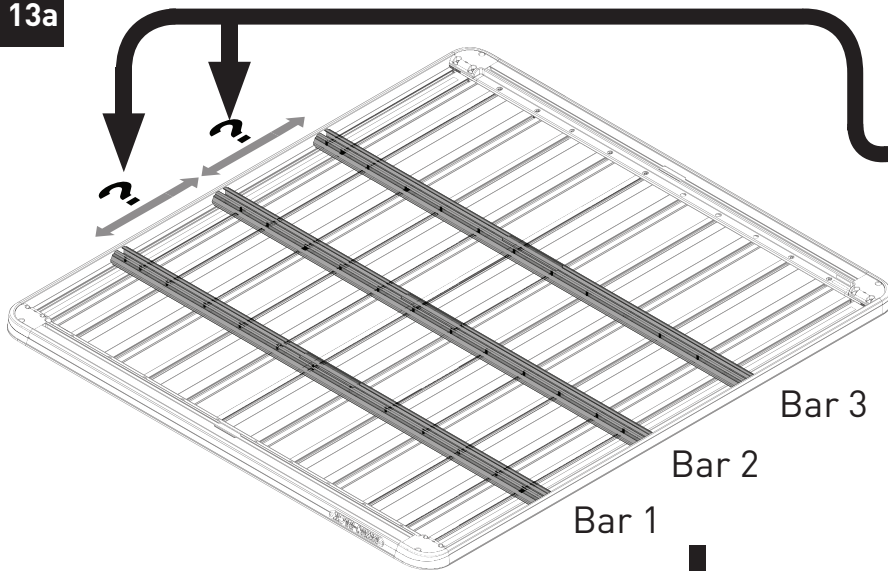

RHINO-RACK | PIONEER VEHICLE FITTING INFORMATION

VEHICLE	PIONEER SIZE	CONNECTOR	HEIGHT ADDED (mm / in)					
EXAMPLE ONLY	5300	RCL	120.0 / 4.7					
IMPORTANT NOTES RCP48-BK required. Fixed point factory mount. -								
REGION	AUS	NZ	USA	CA	SA	UK	EU	ZA
AVAILABILITY	✓	✓	✓	✓	✓	✓	✓	✓
RUNNING DATES	02/15 -	02/15 -	-	-	-	-	-	-
UNDERBAR SPACING								
FRONT	[Diagram showing front view of bars with dimensions A, B, C, D, E, F, G]			REAR				
SIZE NO.	A	B	C	D	E	F	G	
DIMENSION (CM)	42.3	0	42.2					
SPACERS REV'D								
CONNECTOR	RCL		RCL					
VEHICLE LOAD LIMIT (VLL) (kg / lbs)	SYSTEM WEIGHT (SW) (kg / lbs)	ON-ROAD CARRO ALLOW. (OR)	OFF-ROAD CARRO ALLOW. (OF)					
Up to 100 / 220.5 *	19 / 41.2	OR = VLL - SW	OF = OR / 1.5					

*CHECK YOUR VEHICLE OWNERS HANDBOOK FOR VEHICLE MAXIMUM CARRYING CAPACITY. PLEASE ENSURE YOU USE THE VEHICLE MANUFACTURERS MAXIMUM ROOF ALLOWANCE IF IT IS LOWER THAN THE FIGURES LISTED IN THIS INSTRUCTION.

Bar 1, 2, 3

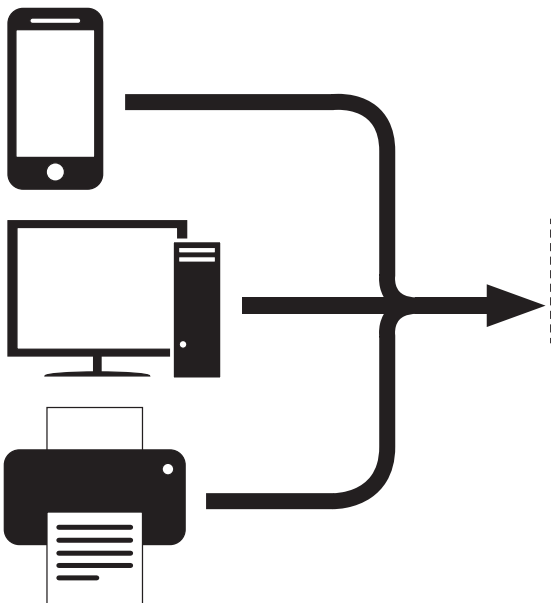

NOTES FOR DEALERS / FITTERS
 It is your responsibility to ensure these fitting instructions are given to the end user or client.

Document No. 9259
 Issue No. 1
 Issue Date: 20-Jun-20
 These instructions remain the property of Rhino-Rack Australia Pty Ltd. and may not be used or changed for any other purpose than intended.

13b

RHINO-RACK PIONEER VEHICLE FITTING INFORMATION

VEHICLE	PIONEER SIZE	CONNECTOR	HEIGHT ADDED (mm / in)
EXAMPLE ONLY	92100	RCL	120.0 / 4.7

IMPORTANT NOTES
RCP58-BK required. Fixed point factory mount. -

REGION	AUS	NZ	USA	CA	SA	UK	EU	ZA
AVAILABILITY	✓	✓	x	x	x	x	x	x
RUNNING DATES	02/15 -	02/15 -	-	-	-	-	-	-

UNDERBAR SPACING

BAR NO	A	B	C	D	E	F	G
DIMENSION (CM)	45.7	B	45.7				
SPACERS REQ'D							
CONNECTOR	RCL		RCL				

VEHICLE LOAD LIMIT (VLL) (kg / lbs)	SYSTEM WEIGHT (SW) (kg / lbs)	ON-ROAD CARGO ALLOW. (OR) (kg / lbs)	OFF-ROAD CARGO ALLOW. (OFR) (kg / lbs)
Up to 100 / 220.5 *	19 / 41.2	OR = VLL - SW	OFR = OR / 1.5

*CHECK YOUR VEHICLE OWNERS HANDBOOK FOR VEHICLE MAXIMUM CARRYING CAPACITY. PLEASE ENSURE YOU USE THE VEHICLE MANUFACTURERS MAXIMUM ROOF ALLOWANCE IF IT IS LOWER THAN THE FIGURE LISTED IN THIS INSTRUCTION.

NOTES FOR DEALERS / FITTERS
It is your responsibility to ensure these fitting instructions are given to the end user or client.

Document No: R2228
Issue No: 1
Issue Date: 20 Jan 20
These instructions remain the property of Rhino-Rack Australia Pty Ltd, and may not be used or changed for any other purpose than intended.

Page 1 of 1

14

J

CLICK!

**6-8NM
4-6LB/FT**

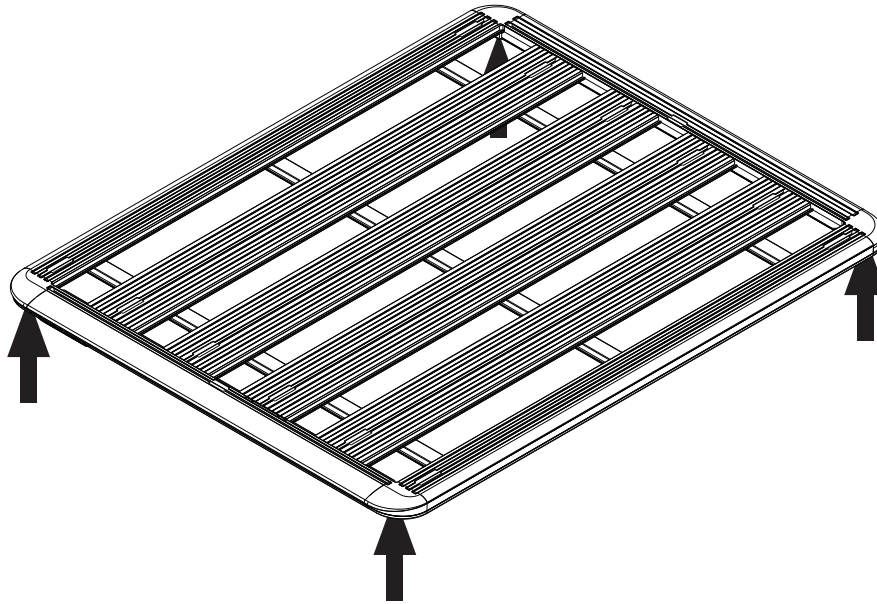

Note - For Wiring
- Para el cableado

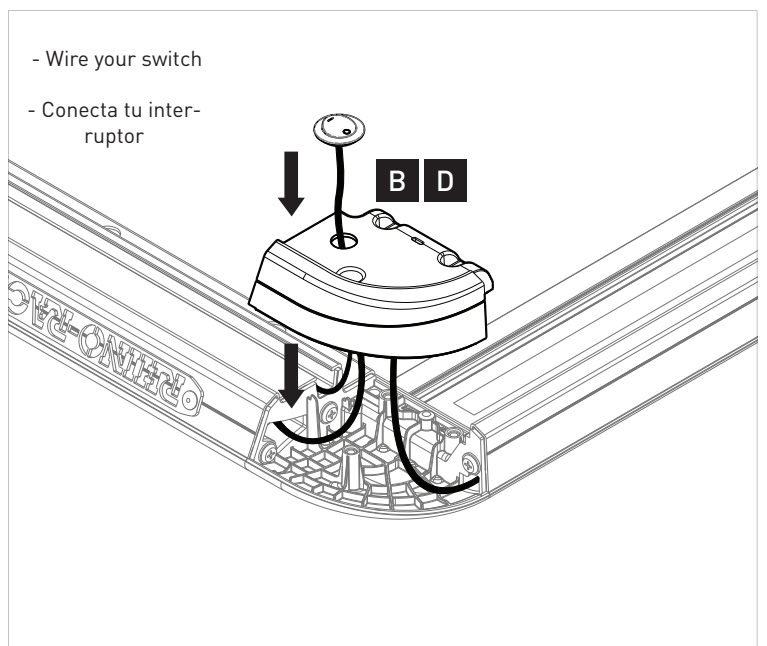
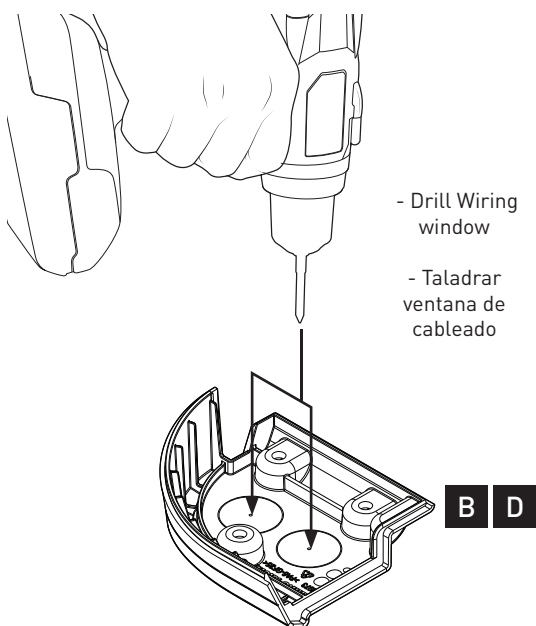
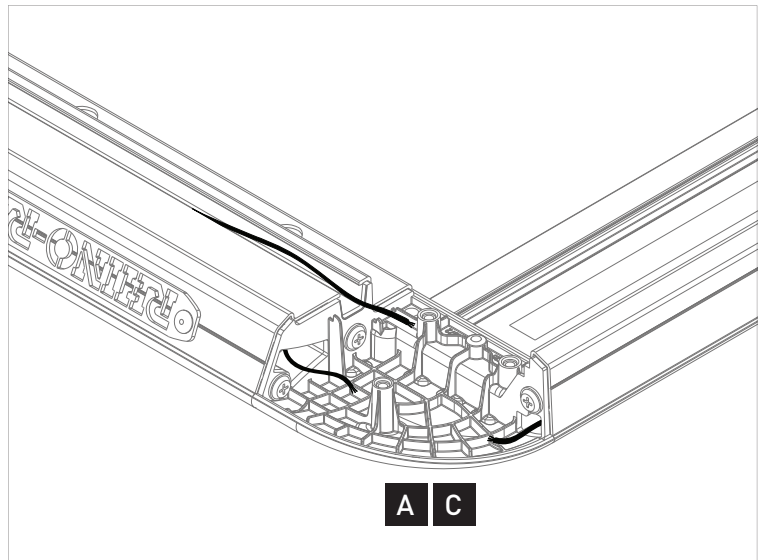
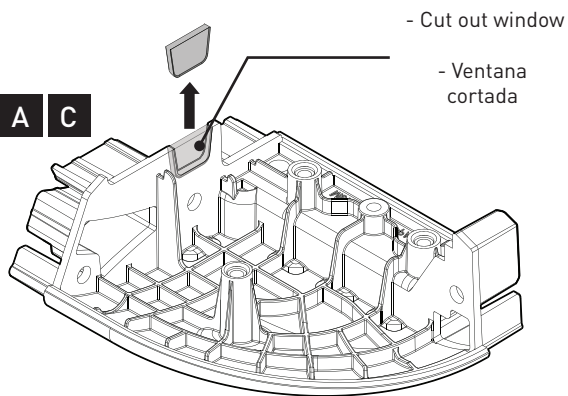

15 RLT600, RCL/RCH,
RL leg variants.

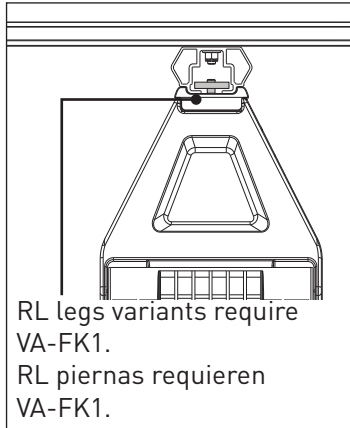
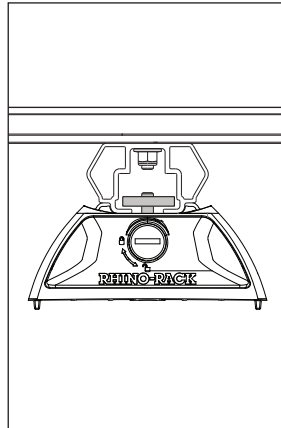
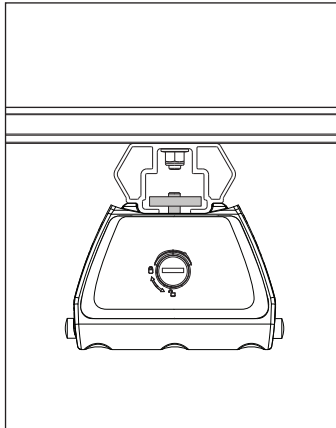
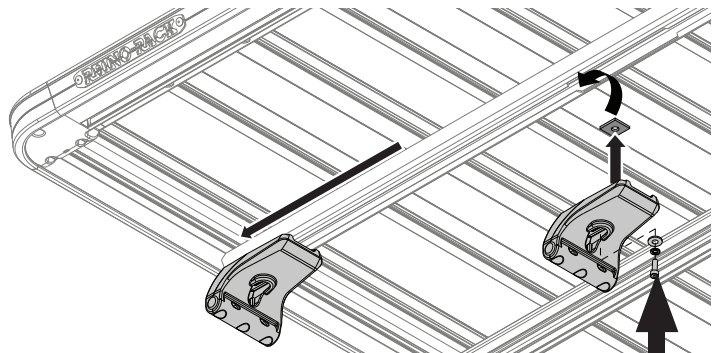
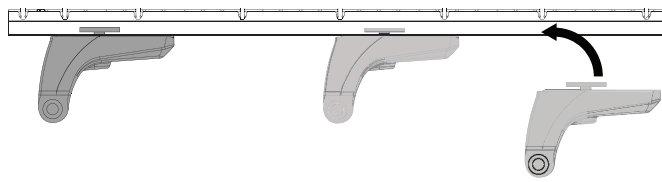

RL legs variants require
VA-FK1.
RL piernas requieren
VA-FK1.

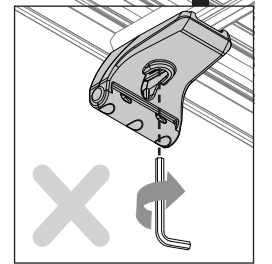

16 SXB

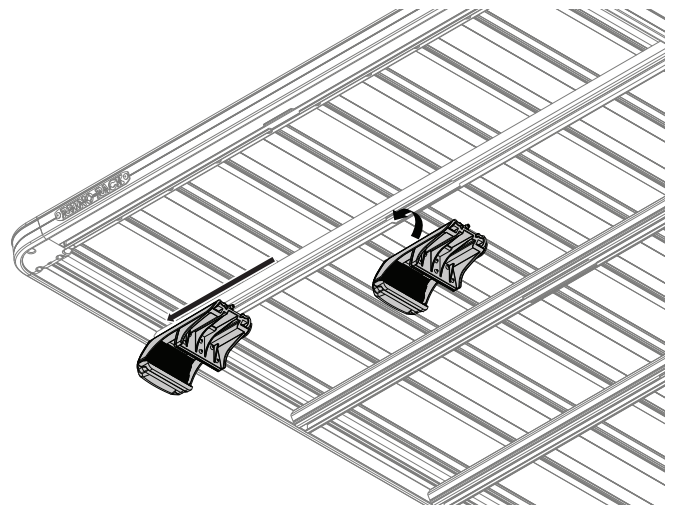
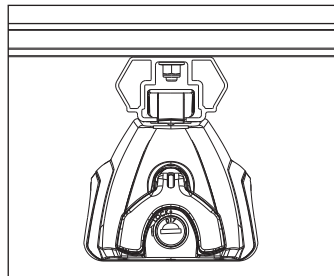
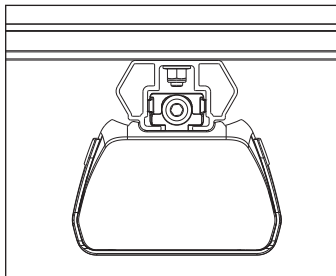
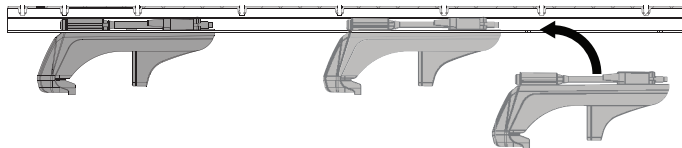

17

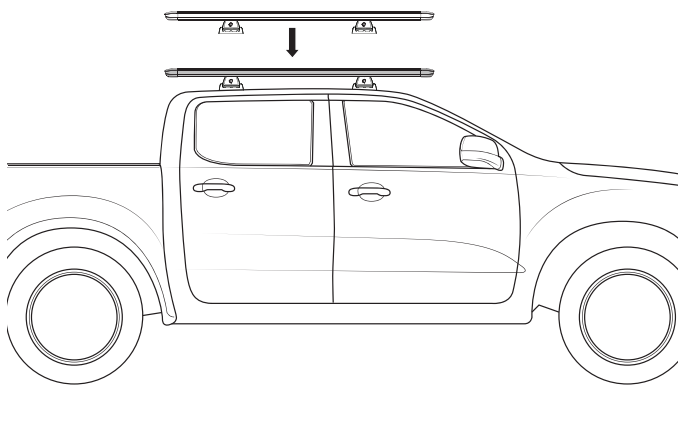

18

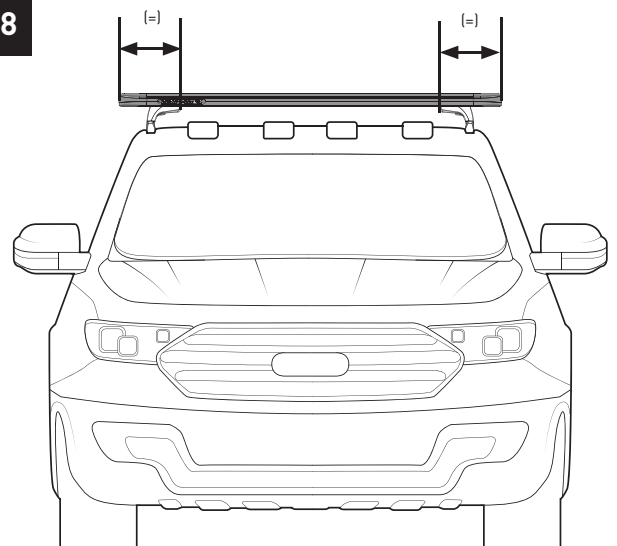

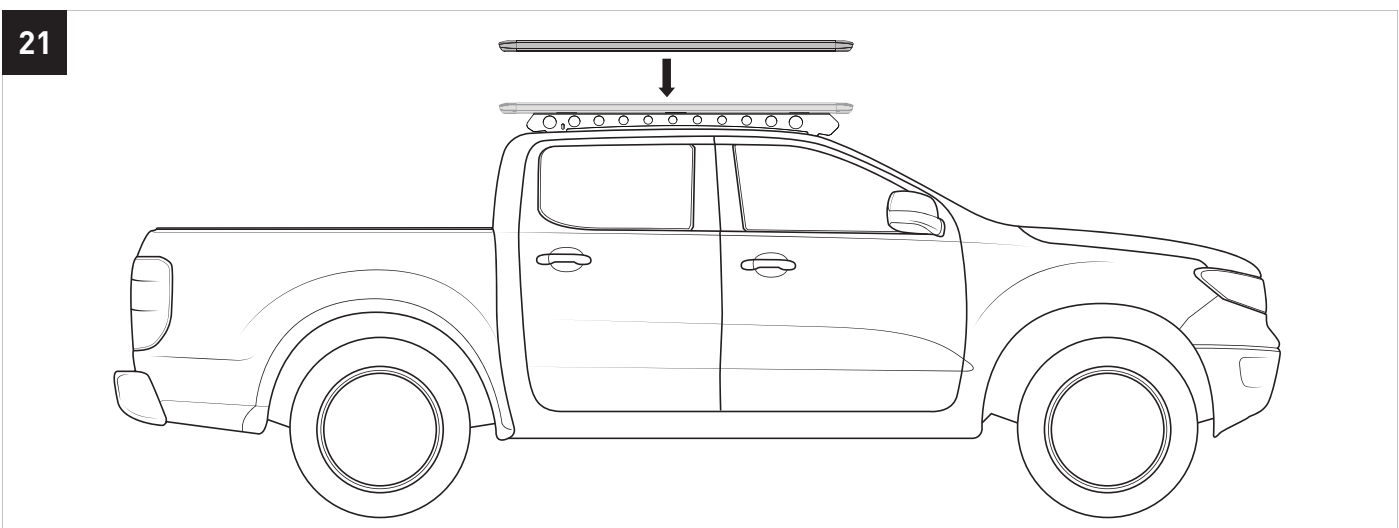
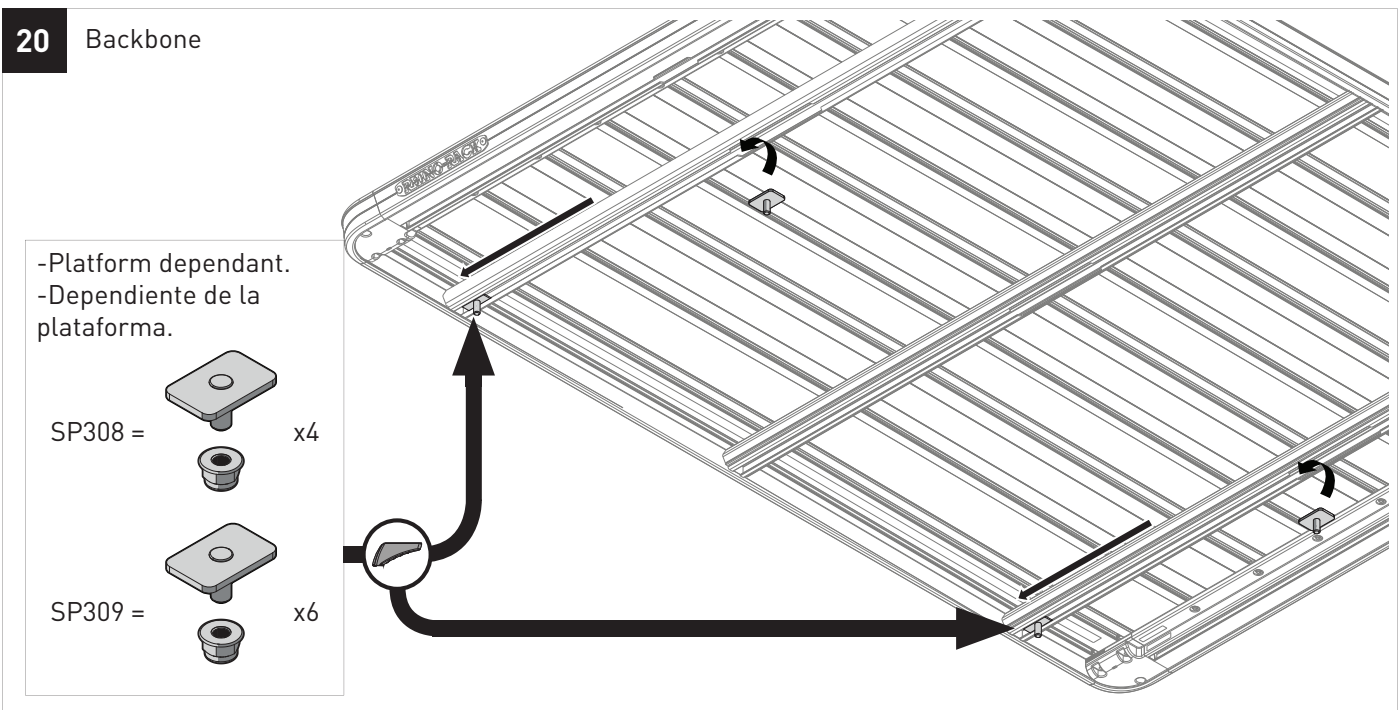
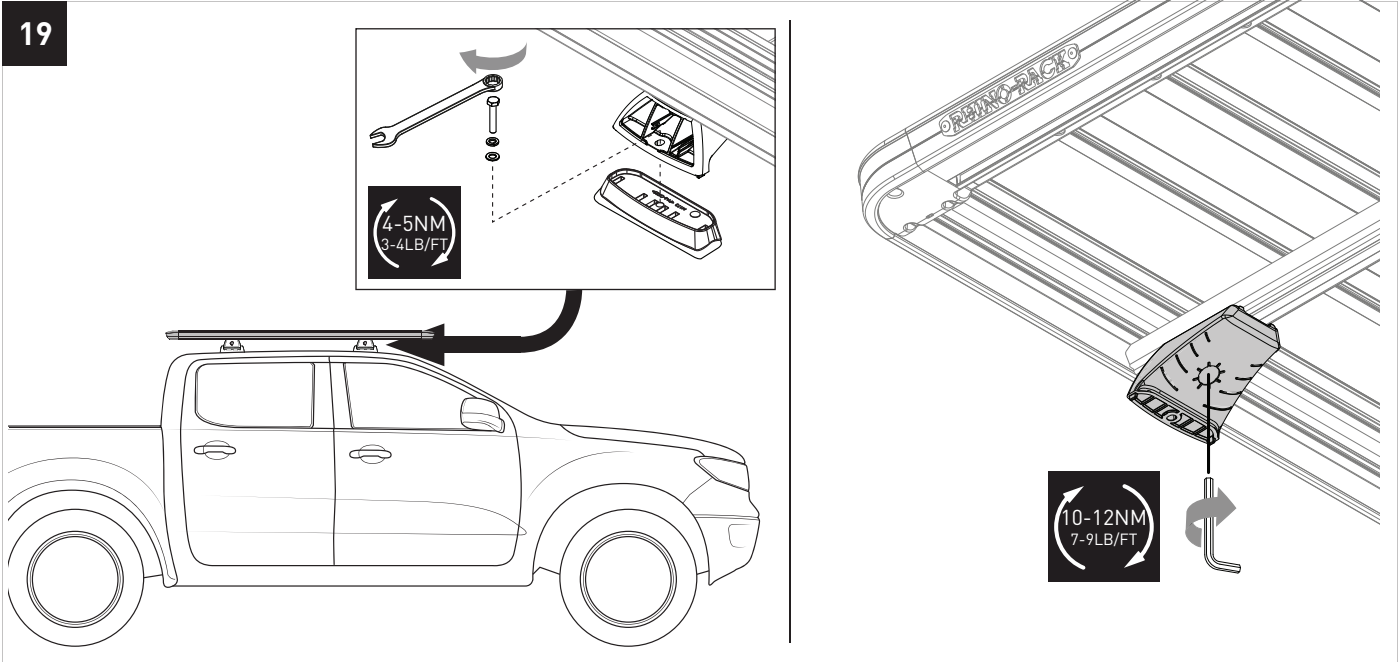

22

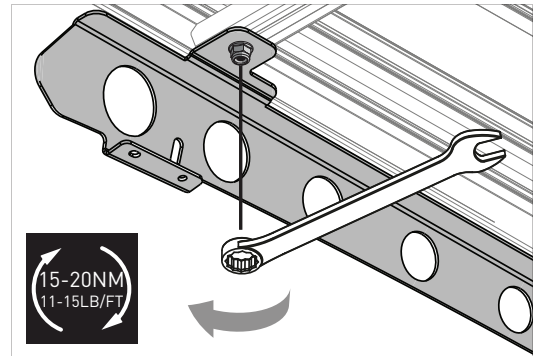
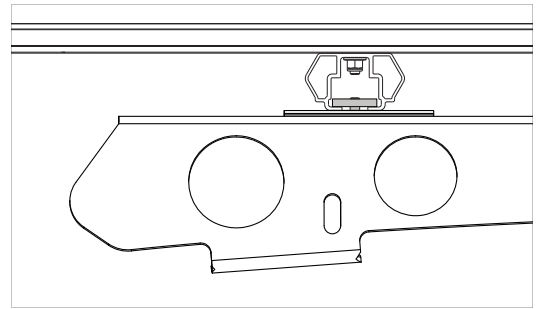
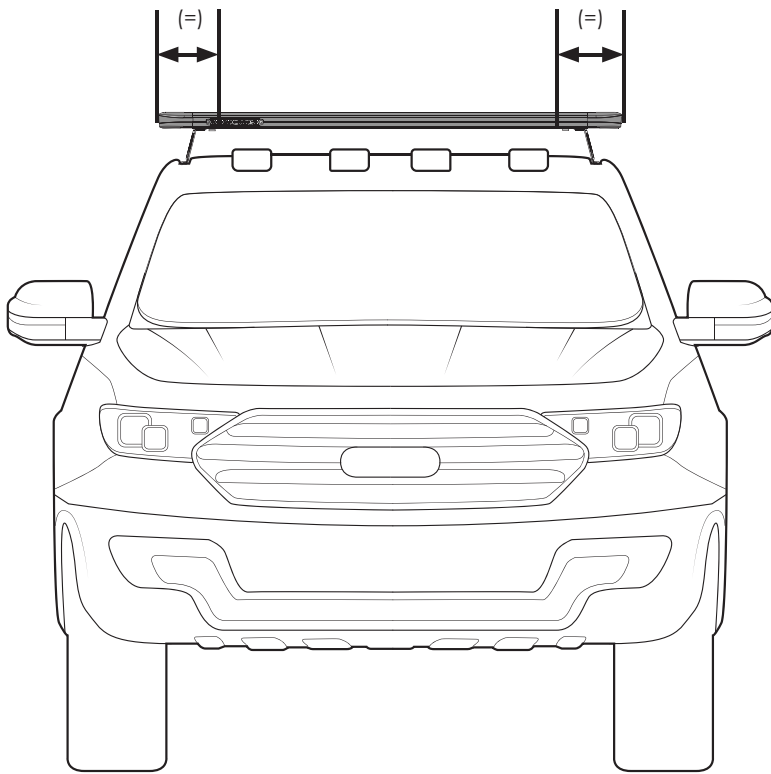

Note

RHINO-RACK
PIONEER ALLOY TRAY (assembled)

QR Code

© 2019 Rhino-Rack, Inc. All rights reserved. Rhino-Rack, the Rhino-Rack logo, and Pioneer are trademarks of Rhino-Rack, Inc. in the United States and other countries. Pioneer is a registered trademark of Rhino-Rack, Inc. in the United States and other countries. Pioneer is a registered trademark of Rhino-Rack, Inc. in the United States and other countries. Pioneer is a registered trademark of Rhino-Rack, Inc. in the United States and other countries.

1-800-451-7273
www.rhinorack.com

RHINO-RACK | PIONEER VEHICLE FITTING INFORMATION

Vehicle	Year	Model	Tray
Subaru	2019-2020	Outback	Pioneer
Subaru	2019-2020	Forester	Pioneer
Subaru	2019-2020	SUV	Pioneer

INSTALLER SPECIFICATIONS

Part	Quantity	Part Number	Part Name
Tray	1	1000000000	Pioneer Alloy Tray
Bracket	2	1000000001	Tray Bracket
Bolt	2	1000000002	Tray Bolt
Washer	2	1000000003	Tray Washer
Lock	2	1000000004	Tray Lock

NOTES FOR DEALERS / FITTERS

1. The tray must be installed on a clean, dry, and flat surface. 2. The tray must be installed on a clean, dry, and flat surface. 3. The tray must be installed on a clean, dry, and flat surface.

