



ROUGH COUNTRY

SUSPENSION SYSTEMS®

92852400

JK 2-DOOR 2007-09 SOFT TOP WITH TINTED WINDOWS



Installation Tips

Before you begin installing this assembly, read all instructions thoroughly.

For a smooth fit:

For ease in installation, the product should be installed at temperatures above 72° F. Below this temperature, the fabric may contract an inch or more, making it difficult to fit to the vehicle. It is normal for fabric to contract and wrinkle when stored in the shipping carton. Within a few days after the installation, the fabric will relax and the wrinkles will disappear.



WARNING

This product is designed to enhance the appearance of the vehicle. Do not rely in any way on the components of this product to contain occupants within the vehicle, or to protect against injury or death in the event of an accident. Never operate vehicle in excess of manufacturer's specifications.

WEAR SEAT BELTS AT ALL TIMES

Read and follow, precisely, all installation instructions provided when installing this product. Failure to do so could place occupants of the vehicle in a potentially dangerous situation. After installing or reinstalling, check to make sure it has been properly installed.



CAUTION

Safety glasses should be worn at all times while installing this product.

Tools Needed

Safety Glasses
Phillips Screwdriver
Masking Tape

Parts List

Fabric Top- 1
Quarter Window, Right- 1
Quarter Window, Left- 1
Rear Window- 1
Elastic Garter- 2

Step One

REMOVE QUARTER WINDOWS AND REAR WINDOW
Remove the Quarter Windows and the Rear Window. Remove the metal Tailgate Bar from the bottom of the Rear Window and set it aside. Release the plastic strip sewn to the top above the doors. Pull down and out to slip the plastic out of the channel.

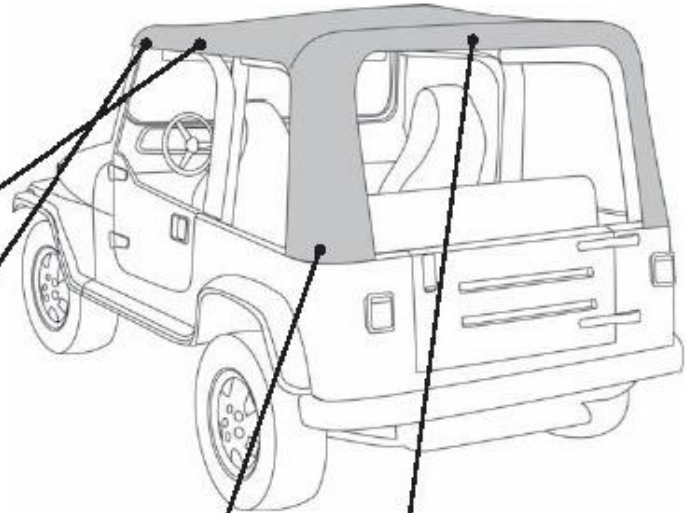
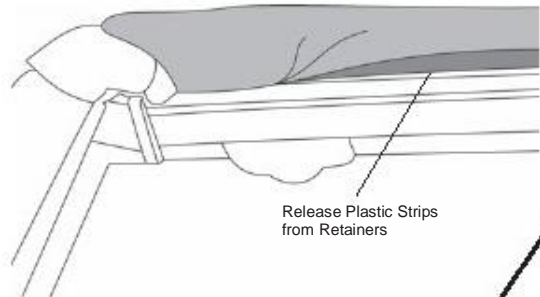

Step Two

RELEASE WINDSHIELD LATCHES

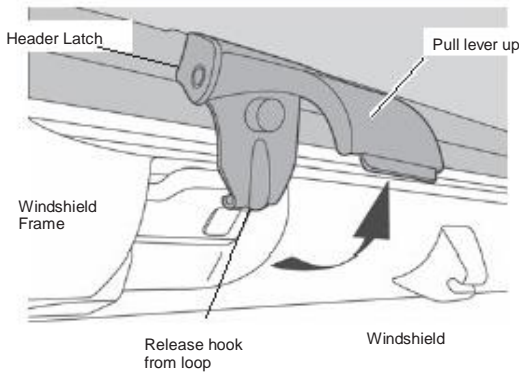

Step Three

RELEASE REAR CORNERS
Release the rear corners of the top. Pull gently down and then out to release the plastic strip from the retainer on the vehicle.

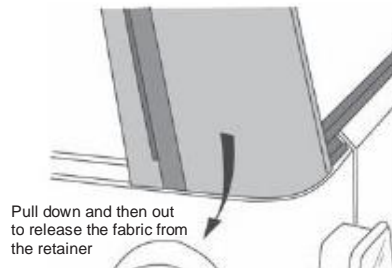

Step Four

Use a phillips screwdriver to remove the four screws that attach the cap in the top to the rear bow. Set the screws aside to be reused later. Allow the bow to drop onto the tailgate.

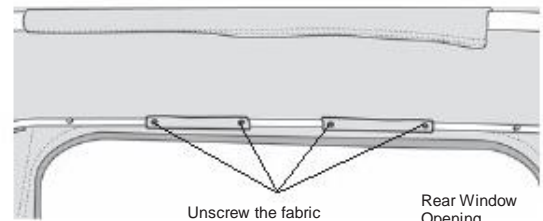

Unscrew the fabric from the rear bow

View from inside vehicle

Step Five

UNFASTEN CENTER BOW

Unfasten the hook and loop 'aps around the Bows on each side of the sport bar.

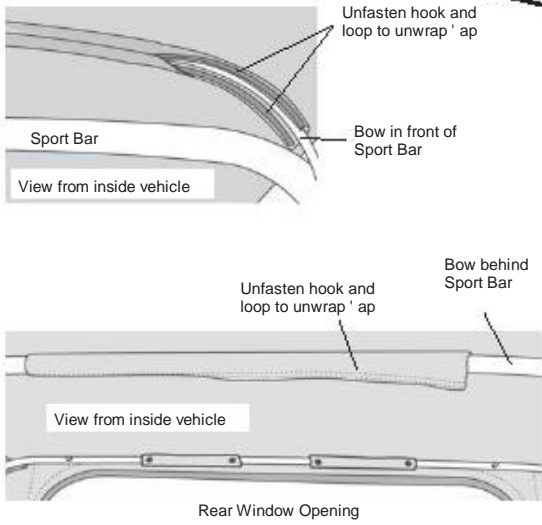

Step Six

REMOVE HEADER SCREWS

Collapse the bow assembly down onto the tailgate to access the header. Remove the two screws that secure the fabric to the header.

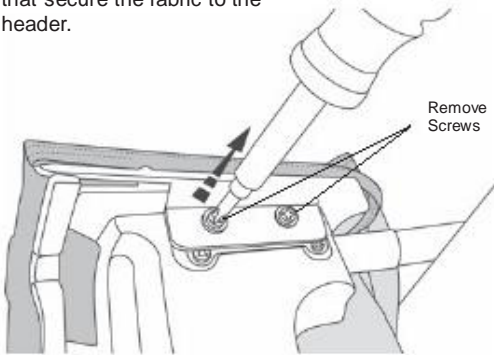

Step Seven

REMOVE TOP FABRIC

Raise the bow assembly and lock the header to the windshield. Drape the top fabric, backing side up, over the hood and windshield. Remove the twenty-seven (27) screws that secure the fabric to the upper and lower headers. Set the screws aside for use in installing the new top. Slide the extrusion along the front edge of the top out of the channel in the lower header and remove the old top from the vehicle.

Top Fabric - Backing Side Up

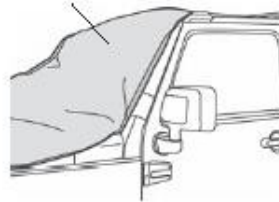

Remove Screws (27) Across Header

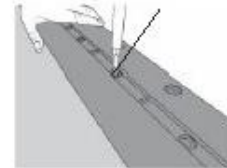

Slide Extrusion along the Front Edge of the Channel to remove Top

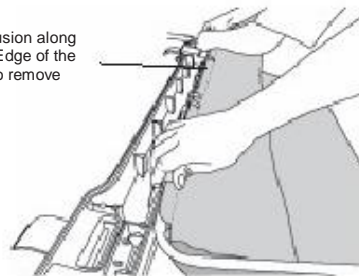

Step Eight

INSTALL TOP FABRIC

Raise the bow assembly and lock the header to the windshield.

Drape the top fabric, backing side up, over the hood and windshield. Slide the extrusion along the front edge of the top into the channel of the top in the lower header. Line up the center notch in the fabric with the center notch in the header. Use masking tape to help hold the fabric in place along the lower header.

Top Fabric - Backing Side Up

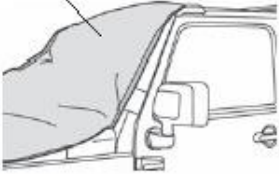

Slide Extrusion along the Front Edge of the Channel

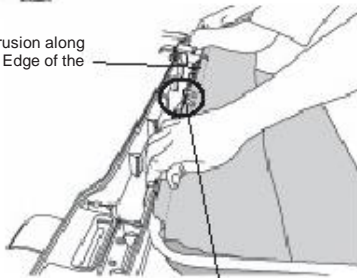

Line up the Center Notch in the Fabric with the Center Notch in the Header

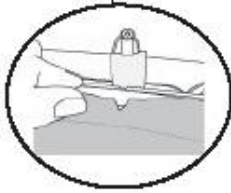

Step Nine

INSTALL TOP FABRIC

Close the upper header over the fabric, sandwiching the fabric. Reinstall the four (4) corner screws. Then install the twenty-three (23) screws across the header.

Reinstall Corner Screws

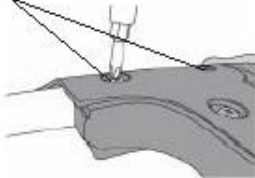

Install Screws Across Header

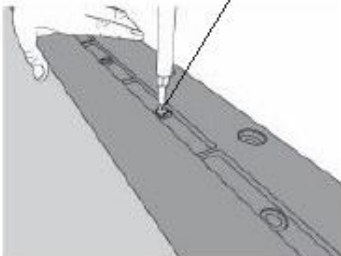

Step Ten

INSTALL CORNER SCREWS

Wrap the fabric around the header and raise the header slightly to work the pockets in the fabric over the corners of the header. Install the screws removed in Step 6 in each corner to secure the fabric to the header.

Install Screws

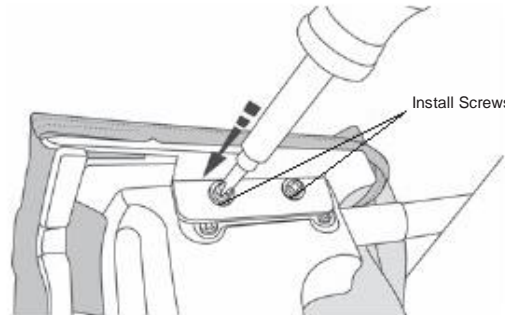

Step Eleven

ATTACH TOP TO REAR BOW

Raise the header and bow slightly to allow you to attach the rear bow 'aps, that are inside the top above the rear window opening, to the rear bow. Use the four (4) screws that were removed in Step 5 to secure the 'aps to the bow.

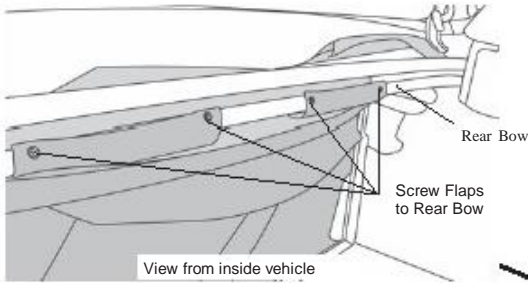

Step Thirteen

SECURE HEADER TO WINDSHIELD

Close the header latches to secure the front of the top to the windshield. Catch the hook in the loop in the windshield frame and then close the lever over it so that it lays 'at against the windshield frame.

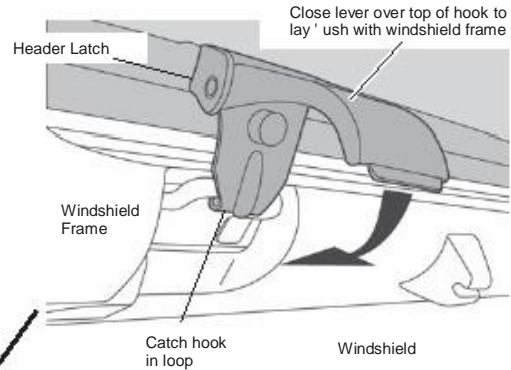

Step Twelve

SECURE CENTER BOWS

Wrap the hook and loop 'aps around the two Bows in the center of the top.

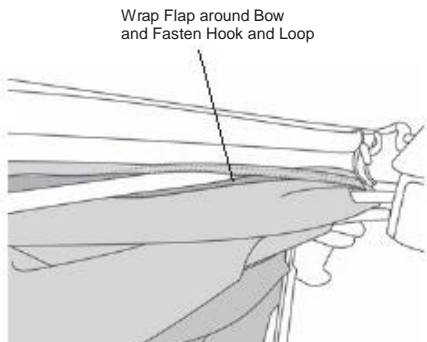
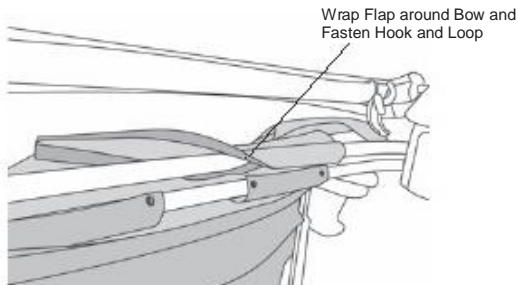

Step Fourteen

SECURE REAR CORNERS

Pull down gently on the Rear Bow and work the plastic sewn to the rear corners of the top into the retainer on the vehicle.

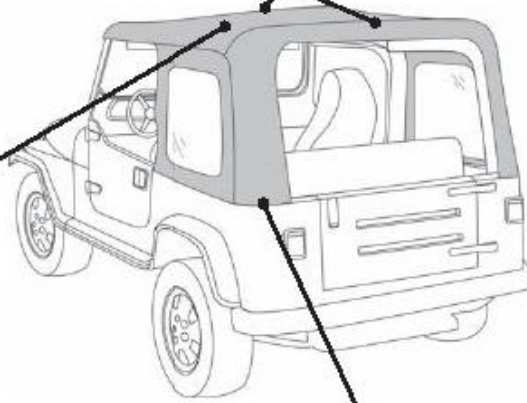
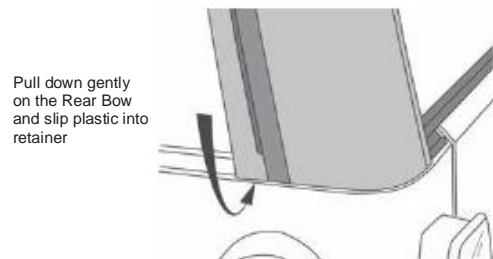

Step Fifteen

ATTACH QUARTER WINDOW ZIPPERS
Start the zipper on the Quarter Window and close it 1-2 inches.

Start Zipper on Quarter Window

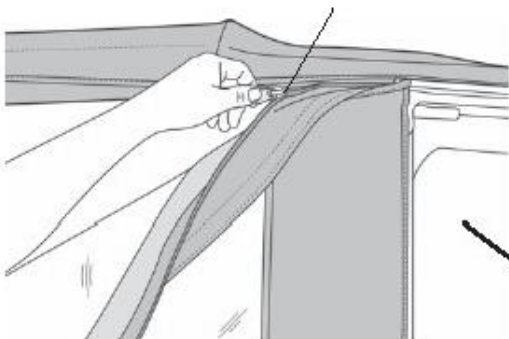

Step Eighteen

SECURE TOP ABOVE DOOR OPENINGS
Slip the plastic strips above the doors into the channel on the vehicle.

Roll Plastic into Channel

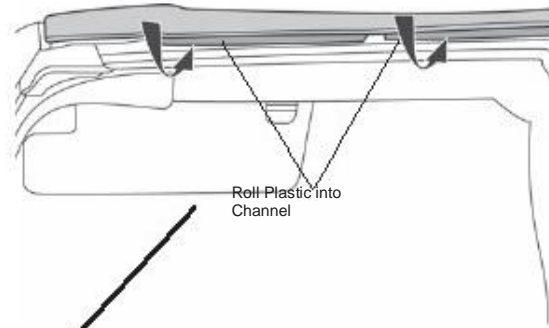

Step Sixteen

SECURE FRONT OF QUARTER PANELS
Roll the plastic strip along the front of the Quarter Window into the channel in the Door Surround.

Roll Plastic Strip into channel in retainer

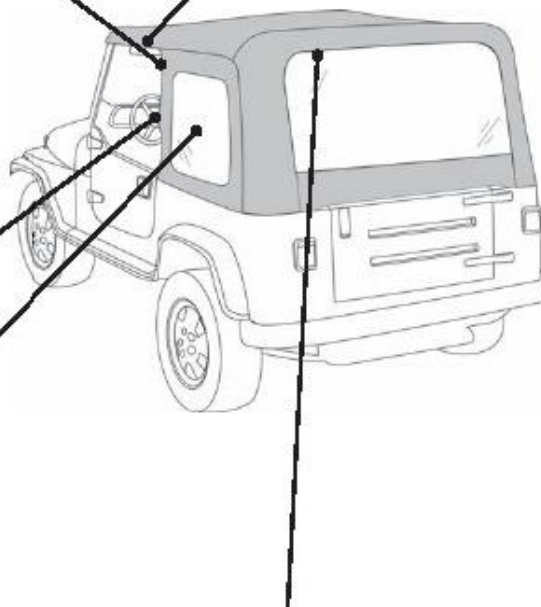
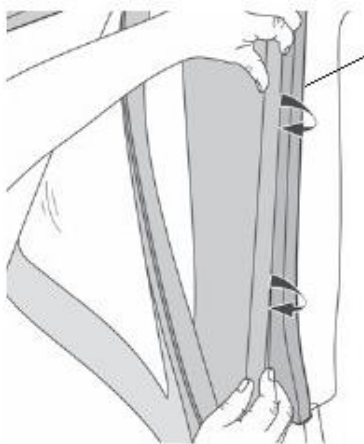

Step Seventeen

SECURE QUARTER WINDOWS
Close the zipper and slip the plastic along the bottom of the Side Window into the channel on the vehicle.
Fasten the hook and loop strip above the window to the top.

Fasten Hook and Loop

Roll Plastic into Channel

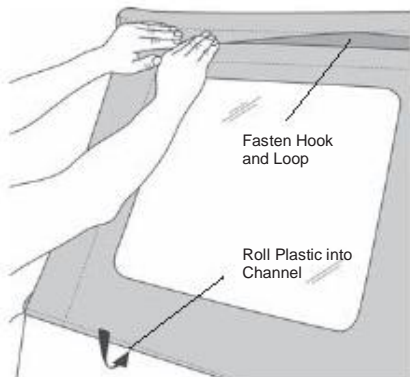

Step Nineteen

INSTALL TAILGATE BAR ON REAR WINDOW
Snap the Elastic Garters to the snaps on the Rear Bow above the rear window opening.

Snap Elastic Garters to Rear Bow

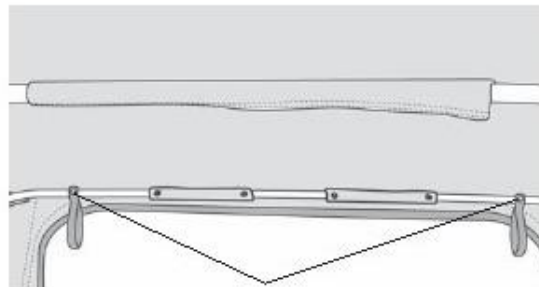

Step Twenty

INSTALL TAILGATE BAR ON REAR WINDOW
Remove the Rear Window from the box and lay it flat with the backing side up. Locate the Tailgate Bar set aside in Step One. The bar has a C-shaped channel, when viewed from the end. Orient the bar with the round seal down and slide the C-shaped channel on the retainer onto the tubed strip sewn to the backing side of the Rear Window.

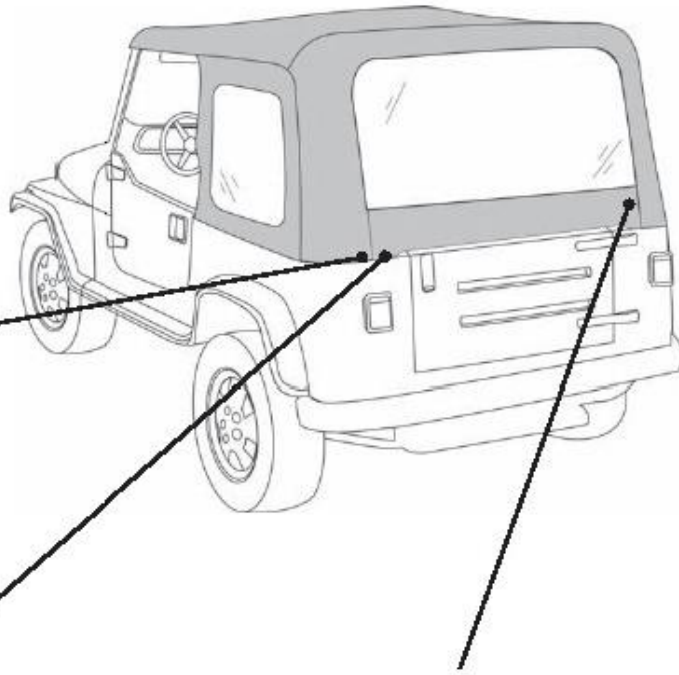
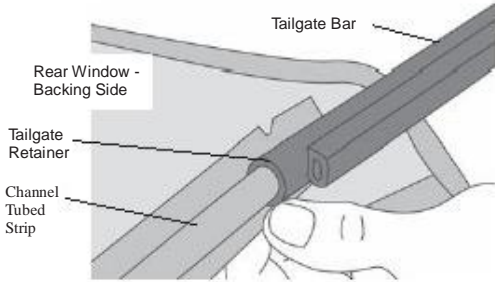

Step Twenty-one

INSTALL TAILGATE BAR ON VEHICLE
Insert the Tailgate Bar into the mounts on each side of the tailgate opening with the vinyl side of the Rear Window toward the outside of the vehicle.

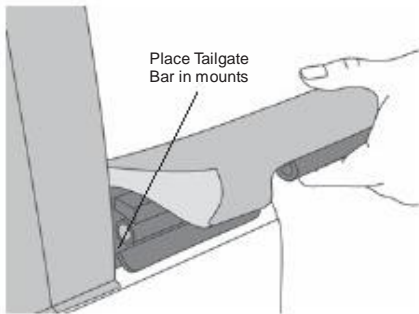

Step Twenty-two

SECURE REAR WINDOW ZIPPERS

To start the zipper, pull the two sliders as far down as possible on the driver's side of the window in order to catch the sliders to the pin.

Once the zipper is caught, start the top slider 1/2". Then hold up the top of the window with one hand and close the zipper with the other. The zipper is sandwiched between layers of fabric in the corners so be careful not to catch extra fabric in the zipper. Close the zipper.

Make sure that the Tailgate Bar is centered and is securely in the mounts. Then tuck the flaps on the Rear Window under the top fabric.

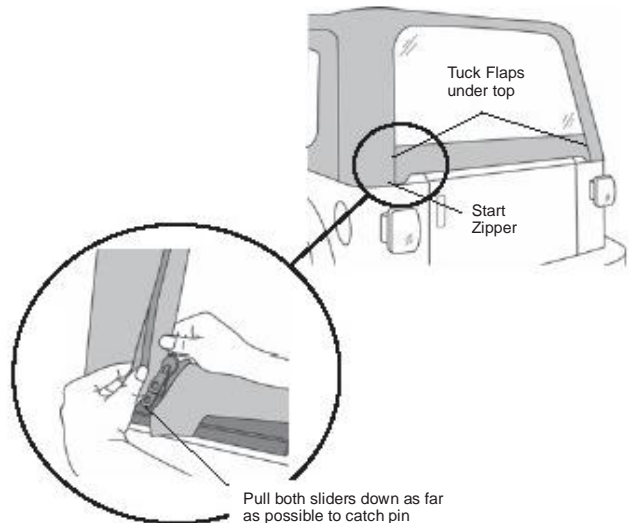

Step Twenty-three

TO FOLD THE TOP DOWN

REMOVE QUARTER PANELS AND REAR WINDOW

Remove the Quarter Panels and the Rear Window. To remove the Quarter Windows, unzip the rear and top zippers. Release the plastic strip from the retainer. Release the Hook and Loop Fasteners from around the Vertical Retainer.

To roll up the Rear Window, remove the Tailgate Bar and open the zippers on each side of the window to the top. Start at the bottom and roll the window to the inside. Avoid wrinkles in the fabric and window. Secure it in place with the elastic garters inside of the top.

****Note**** When operating the vehicle without the Quarter Windows, the Rear Window should be rolled up and secured with the elastic garters for proper ventilation.

Step Twenty-four

TO FOLD THE TOP DOWN

COLLAPSE TOP

Release the front of the top from the windshield. Raise the front of the deck and collapse the rear bows, tucking the two plastic strips above the door openings and the stay pad on the rear bow inside of the bows, Wrap the fabric around the bows, then tuck the rear legs of the top under the bows.

Thank you for purchasing Rough Country products.