



RUBICON EXPRESS 1900 EL CAMINO AVE., SACRAMENTO, CA. 95815 866-533-7706, [www.Rubiconexpress.com](http://www.Rubiconexpress.com)

## INSTALLATION INSTRUCTIONS FOR: RE1132 EXTREME-DUTY SWAY BAR DISCONNECT KIT JEEP WRANGLER 2007-2013 JK w/2.5"-6" LIFT

### **Safety Warning:**

Suspension systems or components that enhance the off-road performance of your vehicle may cause it to handle differently, on and off-road, than it did from the factory. Care must be taken to prevent loss of control or vehicle rollover during sudden maneuvers. Failure to drive the vehicle safely may result in serious injury or death to driver and passengers. We recommend you always wear your seatbelt, drive safely and avoid quick turns and other sudden maneuvers. Constant maintenance is required to keep your vehicle safe. Thoroughly inspect your vehicle before and after every off-road use.

### **Installation Warning:**

We recommend that certified technicians perform the installations of our products. Attempts to install these products without knowledge or experience may jeopardize the safety of the vehicle. These instructions only cover the installation of our products and may not include factory procedures for disassembly and reassembly of factory components. Read instructions from start to finish and be sure all parts are present before disassembling the vehicle. Included instructions are guidelines only for recommended procedures and in no way are meant to be definitive. Installer is responsible to insure a safe and controllable vehicle after performing modifications. Do not perform test drives on public roads with partially completed installations. Always double and triple check your work before use.

**IMPORTANT!: This kit is COMPATIBLE WITH OE sway bars ONLY!**

**NOTE: Extended front brake hoses or other modifications to compensate for additional suspension travel may be necessary.**

**IMPORTANT!: Only disconnect the sway bar for use in approved off-roading areas.**

**IMPORTANT!: WHEN DISCONNECTED, the sway bar must be properly secured to prevent interference all suspension components.**

### **REQUIRED TOOLS:**

Metric/Standard Socket Wrench Set  
(17mm and 3/4" sockets)  
Torque Wrench  
Tie Rod End Remover \*  
6mm Allen Head Socket  
6mm Allen Wrench  
1/4" Allen Wrench \*

15/16" Open-End Wrench  
#1 Philips Screwdriver or Small Punch  
(F) Drill Bit (0.257" equiv.) \*  
5/16" x 18TPI Tap \*  
Angle Measuring Tool  
Grease Gun with Zerk Fitting Coupler  
Wheel Bearing Grease

- *Asterisk denotes tools that are not required certain applications. Read instructions thoroughly before determining which tools will be required for your installation.*

**RE1132 Extreme-Duty Sway Bar Disconnects Kit:**

2	Extreme -Duty Sway Bar Disconnect Upper End	2	Click Pin
2	Extreme -Duty Sway Bar Disconnect Lower End	2	1/2" Nylock Nut
2	Lower Flat Mounting Post: Pass	2	12mm Nylock Nut
2	Lower Tapered Mounting Post:Drvr	2	Polyurethane Spacer
2	Upper Tapered Mounting Post	2	Polyurethane Spacer
2	Urethane Bushing	2	5/8" Jam Nut
		4	Zerk Fitting

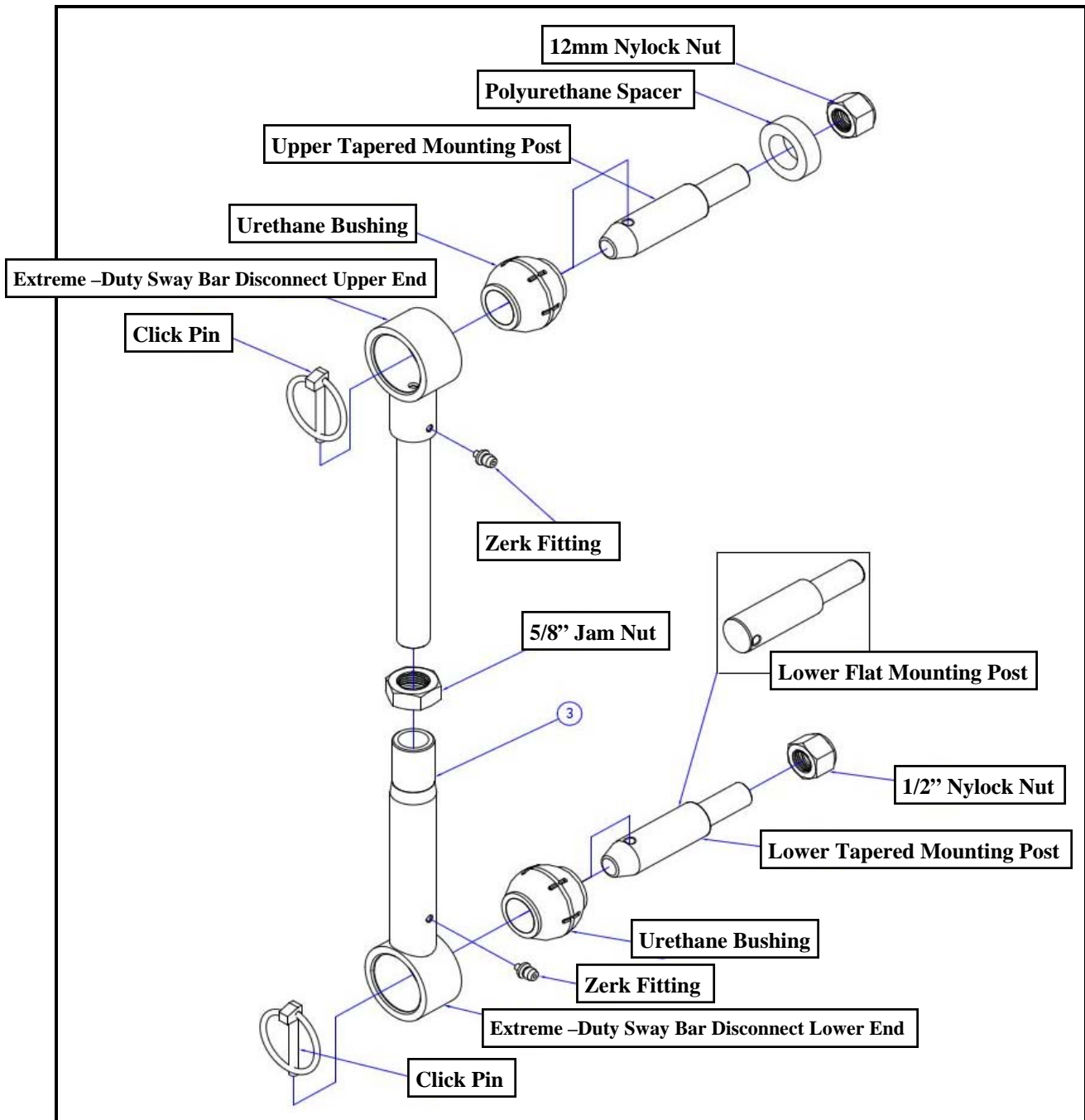

## **SWAY BAR LINK INSTALLATION:**

1. Remove front sway bar end links and OE mounting hardware per the vehicle's factory service manual.
2. Install the **12mm** upper tapered mounting post on the outside of the sway bar. Be sure the click pin holes are horizontal or parallel with the ground.
3. Apply medium strength thread locker to the mounting post threads. Secure the upper mounting post to the sway bar using the **12mm** nylock nuts. Torque **12mm** nut to **65** ft./lbs. (photo 2 & 3)

**NOTE: Inserting a small Philips head screwdriver or punch through the click pin hole will prevent the threaded bullet from rotating when tightening the nut. (photo 3)**

4. Install **1/2"** lower mounting post into the lower sway bar end link front axle mounting holes. Position posts with tapered ends pointing inboard. Be sure click pin holes are horizontal or parallel with the ground. (photo 3)

**IMPORTANT: The passenger side lower mounting post is squared off to provide sufficient clearance between the post and the OE axle track bar bracket. (photo 3)**

**NOTE: Inserting a small Philips head screwdriver or punch through the click pin hole will prevent the threaded bullet from rotating when tightening the nut. (photo 2)**



(Photo #1)



(Photo #2)



(Photo #3)



(Photo #4)



(Photo #5)

5. Apply medium strength thread locker to the mounting post threads. Secure the lower mounting post to the axle mount using the 1/2" nylock nuts. Torque 1/2" nut to 65 ft./lbs. (photo 2 & 3)

6. Determine the proper sway bar angle for your vehicle.

**IMPORTANT: DO NOT exceed maximum length (measured from center-to-center of bushings) for your part. Be sure there is a proper amount of thread engagement.**

7. Adjust the length of the disconnects until sway bar is at the proper angle. (photo 4)

**NOTE: Vehicle must be at normal ride height and located on level ground.**

8. Once adjusted, tighten 5/8" jam nuts firmly against the lower ends.

**IMPORTANT: Bushing ends at both ends must remain parallel with each other while tightening the jam nut.**

9. Install the upper and lower end of the disconnect onto the mounting posts. (photo 5)

10. Insert click pins to secure the disconnects. (photo 6)

**IMPORTANT: When properly installed, the ring on the click pin will sit firmly against the shaft of pin. When installed improperly, the ring will not fit snugly against shaft. (photo 6)**

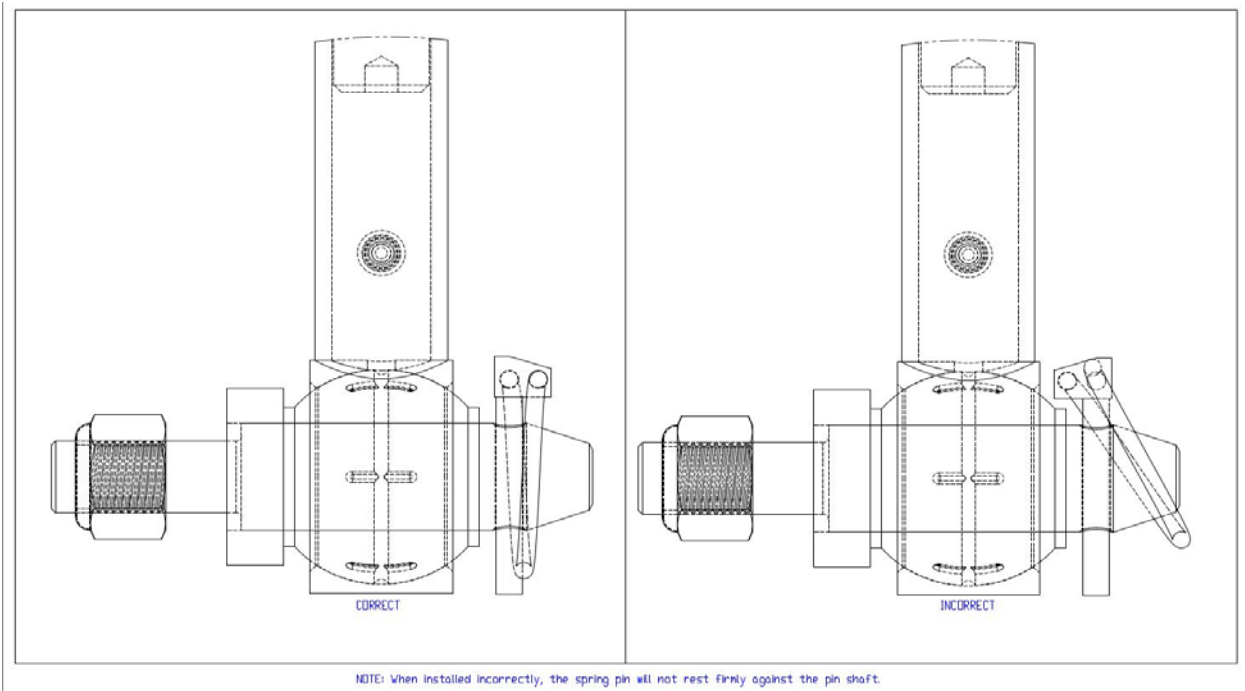

(Photo #6)

11. Lubricate all grease Zerk fittings on the disconnects immediately after installation using common wheel bearing grease or equivalent.

### **CORRECT OPERATION OF EXTREME-DUTY SWAY BAR DISCONNECTS:**

1. Remove the click pins from the upper and lower mounting posts.
2. Remove the disconnects from the mounting posts and store them safely inside the vehicle.

**NOTE: To avoid losing the click pins, reinstall them into the mounting posts.**

3. Secure the sway bar to the chassis, in the horizontal position, with plastic wire ties or bungee cords (not supplied).

**IMPORTANT!: The sway bar must be secured in the horizontal position to prevent serious tire damage.**

4. To reconnect the disconnects, remove the click pins from the mounting posts and rotate the sway bar down into place.
5. Install the upper and lower end of the disconnect onto the mounting posts. **(photo 5)**
6. Insert click pins to secure the disconnects. **(photo 6)**

**NOTE: To make the installation easier, install the passenger side disconnect first.**

### **TROUBLESHOOTING:**

1. If the OE sway bar does not rotate freely, remove it from the vehicle. Clean and apply lubricant to chassis-mounted bushings. Reinstall OE sway bar.

### **MAINTENANCE:**

1. Lubricate all grease Zerk fittings on the disconnects frequently after installation using common wheel bearing grease or equivalent.
2. It is important to lubricate the disconnects frequently after installation.
3. After break-in period, the disconnects should be lubricated as part of the vehicle's regular maintenance schedule.
4. Regular cleaning is recommended to maximize ease of operation and reliability. Always lubricate after any off road adventures.

### **INSTALLATION REVIEW:**

1. Torque all the bolts to factory specifications. Be sure to double check your work.
2. Recheck all bolts after 50 miles and again after every off road excursion.



## RUBICON EXPRESS ADVANTAGE LIFETIME WARRANTY

### ***Notice to Owner, Operator, Dealer and Installer:***

Vehicles that have been enhanced for off-road performance often have unique handling characteristics due to the higher center of gravity and larger tires. This vehicle may handle, react and stop differently than many passenger cars or unmodified vehicles, both on and off-road. You must drive your vehicle safely! Extreme care should always be taken to prevent vehicle rollover or loss of control, which can result in serious injury or even death. Always avoid sudden sharp turns or abrupt maneuvers and allow more time and distance for braking! Rubicon Express reminds you to fasten your seat belts at all times and reduce speed! We will gladly answer any questions concerning the design, function, maintenance and correct use of our products.

Please make sure that the Dealer / Installer explains and delivers all warning notices, warranty forms and instruction sheets included with Rubicon Express product.

Application listings in this catalog have been carefully fit checked for each model and year denoted. However, Rubicon Express reserves the right to update as necessary, without notice, and will not be held responsible for misprints, changes or variations made by vehicle manufacturers. Please call when in question regarding new model year, vehicles not listed by specific body or chassis styles or vehicles not originally distributed in the USA.

Please note that certain mechanical aspects of any suspension lift product may accelerate ordinary wear of original equipment components. Further, installation of certain Rubicon Express products may void the vehicle's factory warranty as it pertains to certain covered parts; it is the consumer's responsibility to check with their local dealer for warranty coverage before installation of the lift.

### ***Warranty and Return Policy:***

Rubicon Express warrants its full line of products to be free from defects in workmanship and materials for the life of the product. Rubicon Express's obligation under this warranty is limited to repair or replacement, at Rubicon Express's option, of the defective product. Any and all costs of removal, installation, freight or incidental or consequential damages are expressly excluded from this warranty. Rubicon Express is not responsible for damages and / or warranty of other vehicle parts related or non-related to the installation of Rubicon Express product. A consumer who makes the decision to modify his vehicle with aftermarket components of any kind will assume all risk and responsibility for potential damages incurred as a result of their chosen modifications.

Warranty coverage does not include consumer opinions regarding ride comfort, fitment and design. Warranty claims can be made directly with Rubicon Express or at any factory authorized Rubicon Express dealer.

### ***Claims not covered under warranty:***

- Parts subject to normal wear; this includes bushings\*, shock absorbers, driveshafts, ball joints, tie rod ends and heim joints.
- Discontinued products at Rubicon Express's discretion.
- Finish after 90 days.

Rubicon Express accepts no responsibility for any altered product, improper installation, lack of or improper maintenance or improper use of our products.

**\*Rubicon Express PT-MEG Super-Ride bushings are covered by the Rubicon Express Advantage Lifetime Warranty, and will be replaced in the event of failure for the life of the product.**