



# TRAIL CAMERA RELOCATION KIT

2018+ JEEP WRANGLER & GLADIATOR

## PLEASE READ ENTIRELY BEFORE YOU START

To guarantee a quality installation, we recommend reading these instructions thoroughly before beginning any work. These instructions assume a certain amount of mechanical ability and are not written nor intended for someone not familiar with auto repair.

## TABLE OF CONTENTS

- I. Vehicle Preparation
- II. Camera Installation

## REQUIRED TOOLS

- Common Hand Tools including Metric Wrenches or Sockets
- Allen Drivers
- T-20 Torx driver
- Thin needle nose pliers
- Center Punch
- Sharp Knife or Clippers

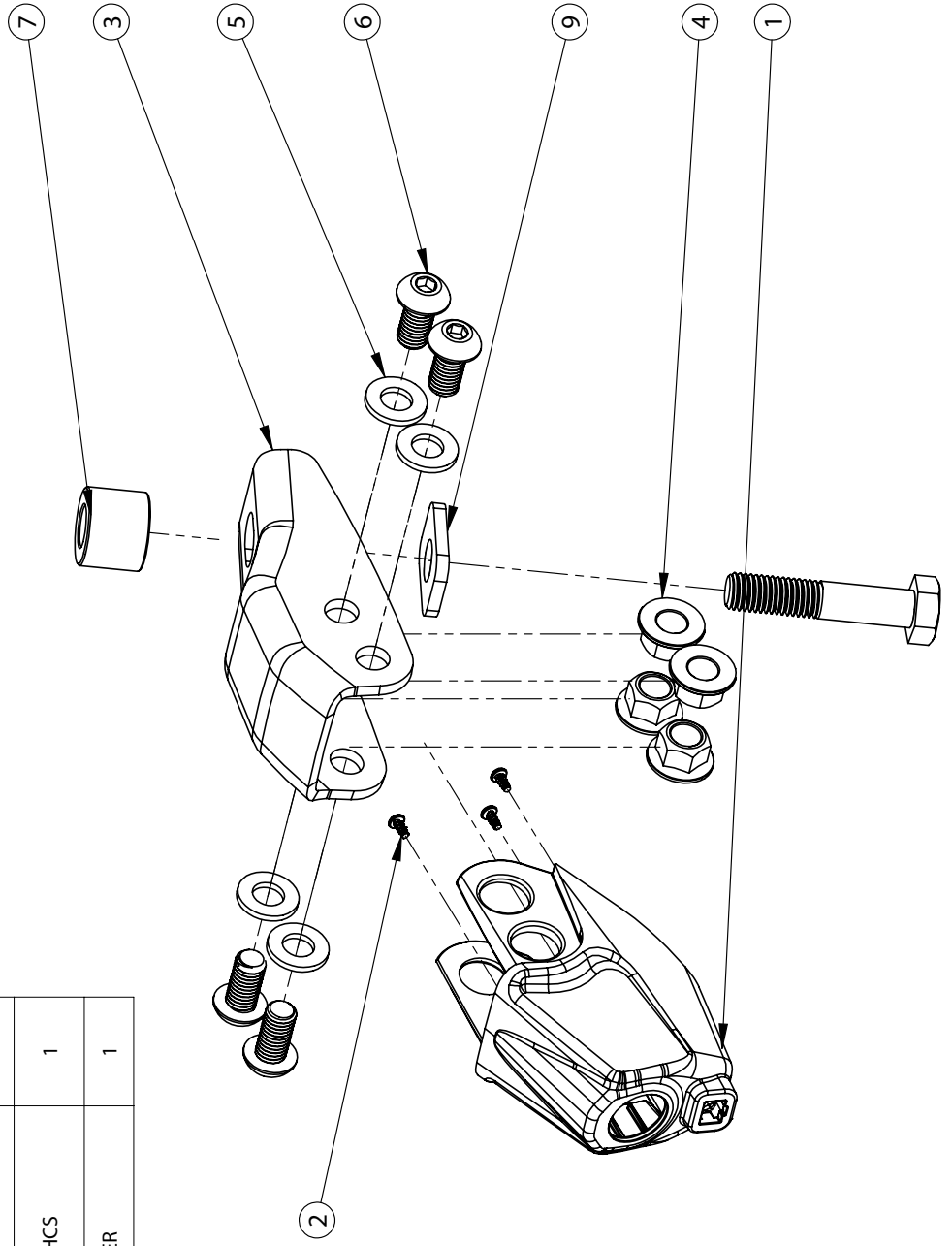
It is recommended to purchase the standard Mopar Grill insert (PN:6QN22RXFAB) to replace the camera mount grill insert.



# TRAIL CAMERA RELOCATION KIT

2018+ JEEP WRANGLER & GLADIATOR

| ITEM NO. | PartNo     | DESCRIPTION                | QTY. |
|----------|------------|----------------------------|------|
| 1        | AJLB116AA  | CAMERA BRACKET             | 1    |
| 2        | AEV91168AA | #4 X 1/4" PHILLIPS SCREW   | 3    |
| 3        | AJLB1042AA | LIGHT BRACKET              | 1    |
| 4        | 11546366   | M10 X 1.5 FLANGED LOCK NUT | 4    |
| 5        | AEV98006AA | M10 FLAT WASHER            | 4    |
| 6        | AEV91010AA | M10 X 1.5 X 20 RHCS        | 4    |
| 7        | AJLB1103AA | ROUND SPACER               | 1    |
| 8        | AEV91065AA | M12 X 1.75 X 60 HCS        | 1    |
| 9        | AJLB1038AA | SQUARE SPACER              | 1    |





## I. VEHICLE PREPARATION

1. Remove OEM front bumper as instructed in bumper installation instructions.
  2. Remove OEM grill, camera housing, and washer nozzle.  
NOTE: If camera relocation kit is being installed after AEV bumper, the bumper will need to be almost fully removed/loosened in order to free up enough space to remove grill. Follow bumper installation instruction in reverse order until tube weldment and back side reinforcement brackets are able to be moved out of the way in order to remove the grill. Most winches (if equipped) will also need to be removed in order to remove the grill.
- A. Pull the front of the driver side wheel liner up and locate the wiring harness and rubber hose along the frame rail by the forward body mount. Disconnect the wiring harness and rubber hose quick connect. We recommend clamping off the rubber hose upstream of the connector, otherwise washer fluid will run out the exposed end once disconnected. Unclip the wiring harness from the retainer bracket and cut off the Christmas-tree wire tie (fig. 1).

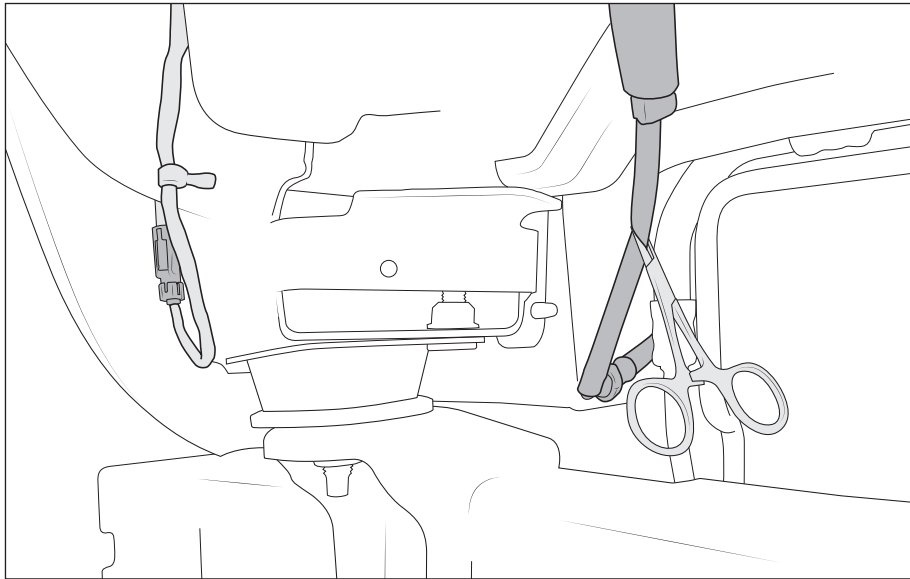


Figure 1

- B. Open the hood and remove the 6 plastic push-rivets retaining the top of the grill shell to the radiator support (fig. 2). Remove the grill by grabbing the bottom flange and pulling straight outward. Once the push-rivets are removed at the top, the grill is only held in by the spring clips at the bottom. Don't pull too far, as the wiring harness and washer hose are still attached to the grill.

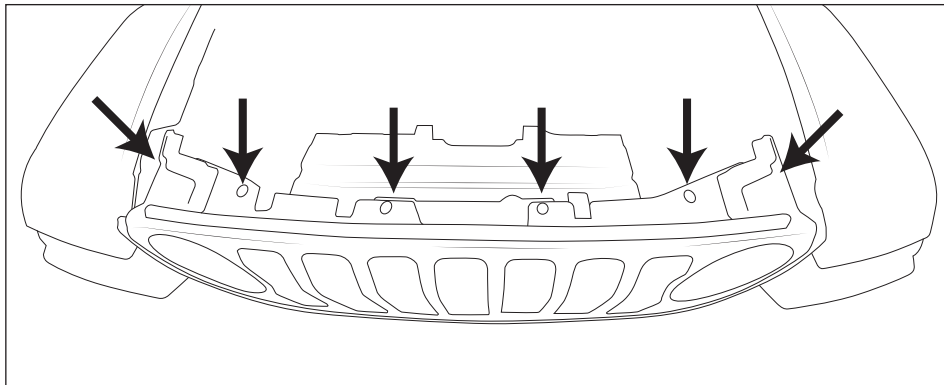


Figure 2



- C. Once the grill is loose, lean it forward to access the camera connections. Squeeze the quick connect at the washer nozzle to disconnect it and then the wiring connector from the grill (fig. 3).

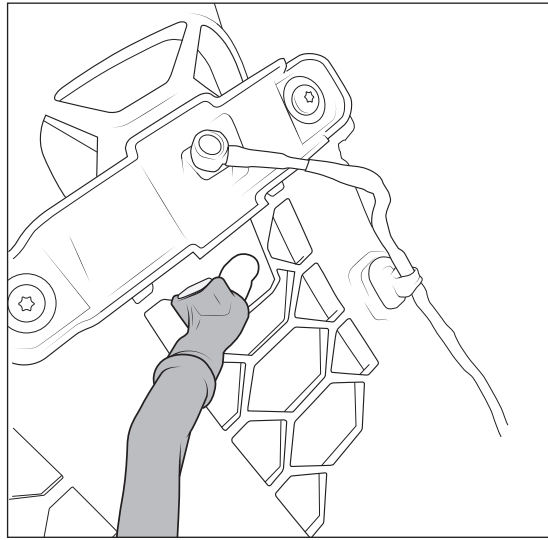


Figure 3

- D. Mark the 1-way valve washer line to show proper orientation in vehicle (fig. 4). Mark the side toward the nozzle for easy identification later. Reinstalling it backward will prevent fluid flow to the washer nozzle. Unclip the hose from the radiator support bar (fig. 5) and snake it through the radiator support and remove it completely. Save the 1-way valve and the rear quick connect. The rest will be discarded.

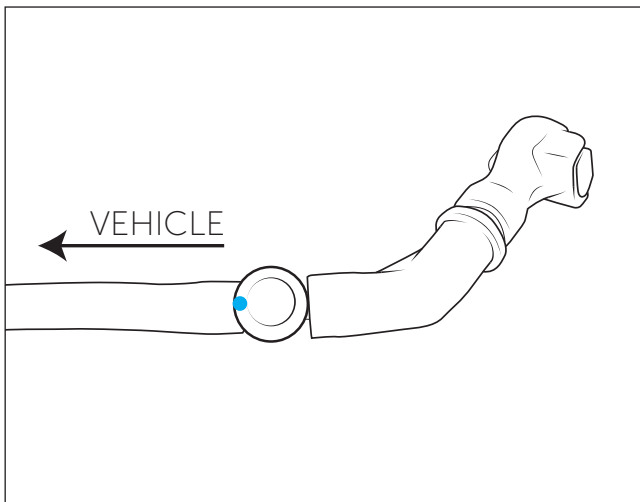


Figure 4

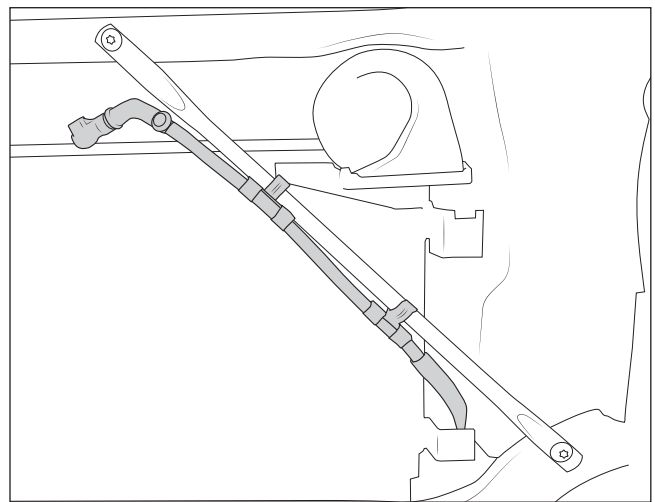
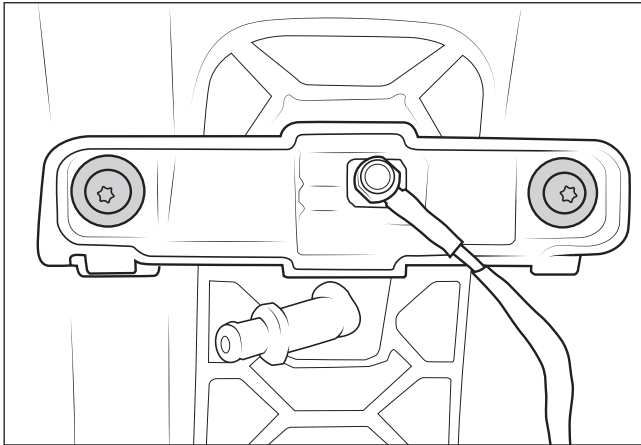


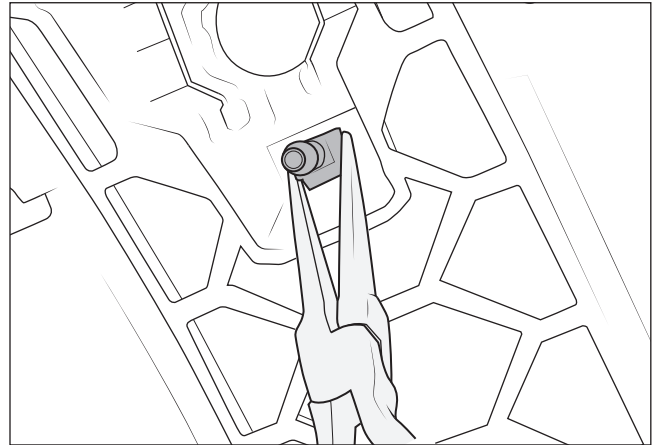
Figure 5



- E. Set the grill face-down on a soft surface to prevent scratching. Disconnect the camera harness and use a trim tool or flat head screwdriver to remove the wire tie retainers from the grill. Remove harness completely and trim off the old wire tie retainers, being careful not to damage any wires or insulation. Remove the two T-20 torx screws holding the camera retainer into the grill insert (fig. 6). Discard the retainer and **SAVE** the screws. Remove the camera and then use thin needle nose pliers to squeeze the retainer clips on the washer nozzle and remove it from the grill insert (fig. 7). **If desired, remove the T-20 Torx screws and two plastic clips holding the center grill insert, remove it, and replace with 6QN22RXFAB Mopar insert. Replace original hardware and tighten until snug.**

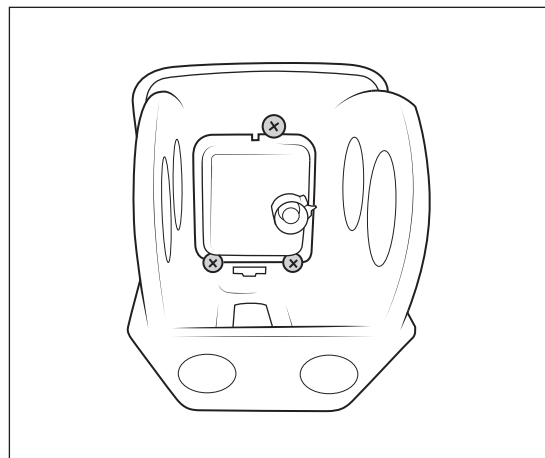


*Figure 6*



*Figure 7*

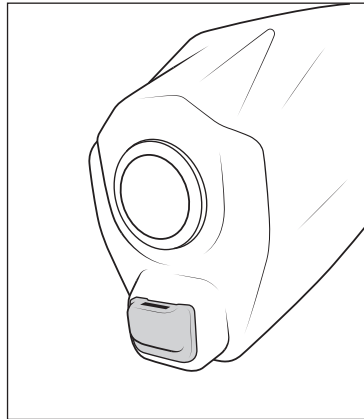
- F. Reinstall the grill onto the vehicle. Snap the bottom clips in, then install the original push-rivets.
- G. Install camera into AEV relocation housings. It will only fit 1 way due to the alignment tabs. When looking from the rear of the housing with the mounting tabs facing up, the connector should be on the right hand side. Use the 3 small screws provided in the kit to retain the camera into the housing. Tighten only until snug, overtightening can strip or crack the plastic housing (fig. 8).



*Figure 8*

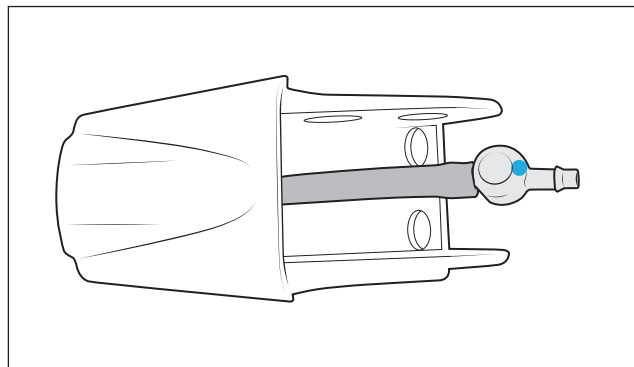


- H. Clip the washer nozzle in from the outside of the housing so that the nozzle is pointed at the camera lens (fig. 9).



*Figure 9*

- I. Cut off 4" of the supplied hose. Insert one end onto the washer nozzle barb fitting, being sure it seats fully. Thin needle nose pliers will help due to the tight clearances. Install the end of the 1-way valve with the marking from step I-4 onto the other end of the hose attached to the nozzle (fig. 10).



*Figure 10*



## II. CAMERA INSTALLATION

1. Install Bumper Hoop and Back Side Support Brackets. Follow bumper installation instructions up until the hoop is installed onto vehicle (step II – 7).
2. Install stamped steel mounting bracket to the center weld nut in the bumper hoop. The hardware order is bolt, regular washer, square washer, stamped bracket, tube spacer, then install onto the bottom of the bumper hoop. Make sure it's pointed straight forward and torque to 50 lb-ft (fig. 11).

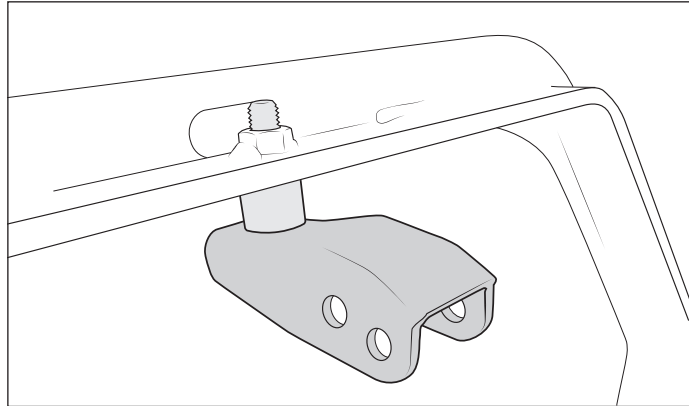


Figure 11

3. Install the chassis-side quick connect fitting saved from earlier to the end of the long supplied hose (fig. 12). Feed the fitting through the bumper brackets as shown below (fig. 13). Route it safely through the radiator support and along the frame, to the other end of quick connector behind the wheel liner. Be sure to avoid sharp edges and snag points. Connect the fitting but do not remove the clamp on the line yet.

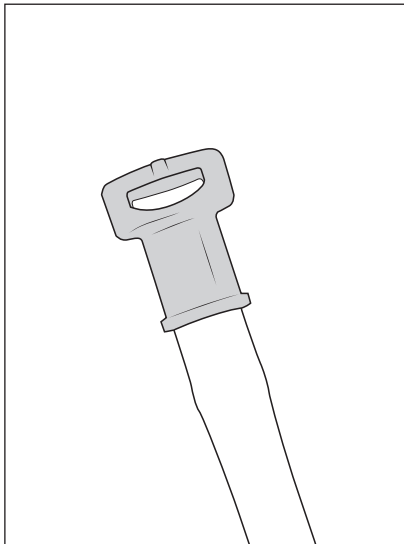


Figure 12

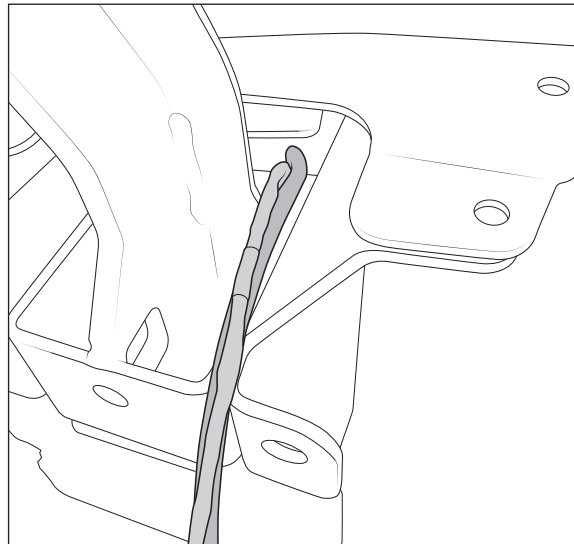
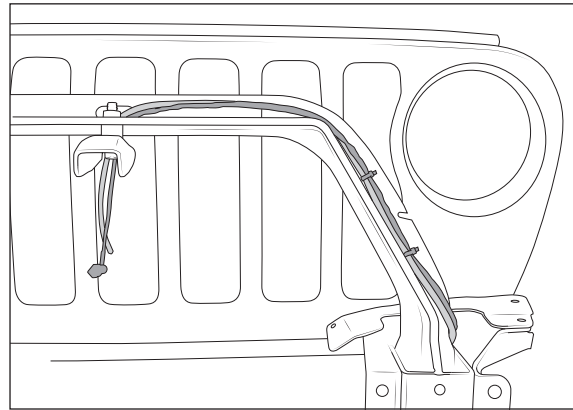


Figure 13

4. Route the camera wiring harness along side the washer hose (see fig. 13). Be sure that the straight connector goes on the chassis side and the 90° connector goes toward the camera.

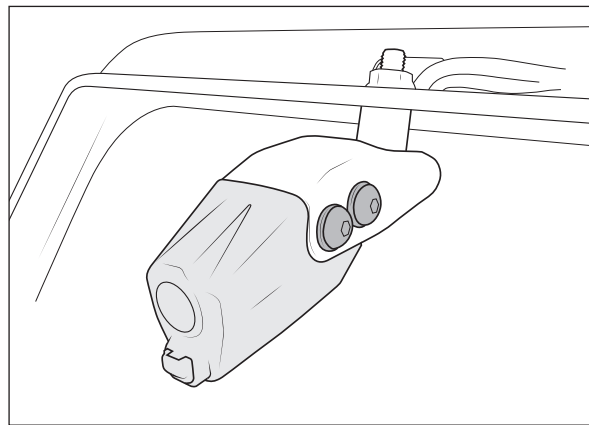


- Loosely attached the harness and hose to the bumper hoop using the provided Christmas tree wire ties on the holes in the hoop. Route the harness and hose through the large slot in the back center of the hoop. Ensure the connector at the camera end has enough slack to reach the camera once mounted into the bracket. Route the chassis harness inboard over the support bracket behind the radiator, loosely wire tie it to the power steering line, and make sure it's routed properly and with enough slack to allow it to reattach at chassis side connector. Reconnect, then tighten and trim the wire ties (fig. 14).



*Figure 14*

- Connect the camera and then measure and trim any excess hose going to the washer nozzle. Attach hose end to 1-way valve.
- Install the camera relocation housing to the stamped bracket using provided M10 button head bolts and washers on the outside, with flange nuts on the inside. Tighten bolts until snug. Overtightening can crack the plastic (fig. 15).



*Figure 15*

- Finish the rest of the bumper installation.