

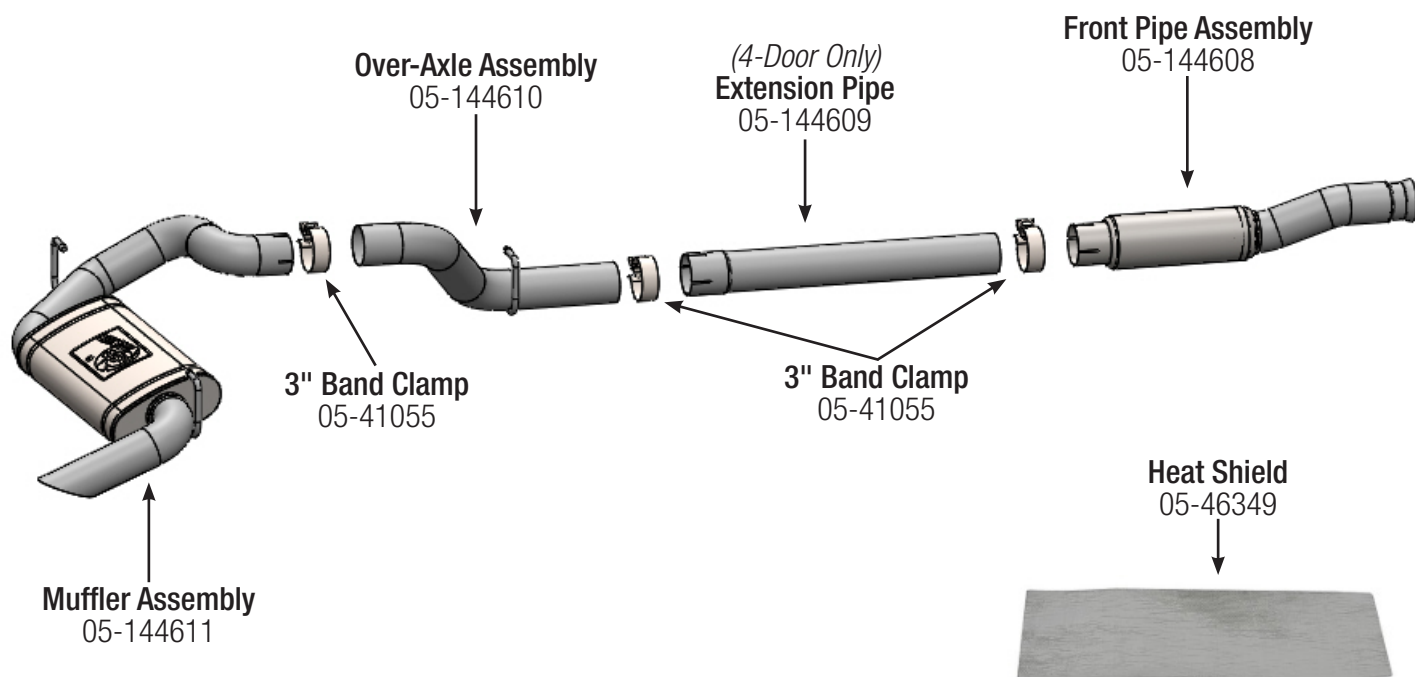

INSTALLATION INSTRUCTIONS

MAKE: Jeep
MODEL: Wrangler (JL)
YEAR: 2018 - 2019
ENGINE: I4-2.0L (t)
FITS: 2 / 4 Door

Cat-Back Exhaust
49-48079



Caution: aFe recommends professional installation on our products. Allow time for your vehicle to cool down prior to installation. When working on or under your vehicle proceed with caution. Exhaust systems reach high temperatures and may cause serious burns. Wear protective safety equipment; eye goggles and gloves to ensure a safe installation.

- Step 1:** **(Read Instructions prior to installation).** It may be helpful to lubricate all the factory isolation rubber mounts, before taking off stock exhaust and before installing aFe exhaust. Always use a jack or stand for support when installing or uninstalling any exhaust system.
- Step 2:** Begin by removing your stock exhaust from the rear of your Jeep working your way forward. Remove the factory muffler assembly and mid-pipe/resonator. Take caution not to damage the factory isolation mounts as they will be reused NOTE: It may be easier to unbolt the muffler hanger brackets from the frame than to disconnect the factory isolation mounts.
- Step 3:** Remove the factory ball clamp from the mid-pipe/resonator.
- Step 4:** For faster installation spread the pieces of the exhaust alongside of your vehicle, according to the diagram shown. It is recommended to not fully tighten any of the clamps until the entire system has been fully installed.
- Step 5:** Clean the area on the driver's side cargo tray (behind the driver). Install the supplied Heat Shield on the cargo tray. Refer to **Photo A**.
- Step 6:** Place the factory ball clamp removed in **Step 3** onto the Front Pipe Assembly.
- Step 7:** Install the Front Pipe Assembly onto the factory down-pipe and loosely tighten the factory ball clamp.
- Step 8:** Place a 3" band clamp over the rear side of the Front Pipe Assembly (If vehicle is a 4-door, slide the Extension Pipe into the Front Pipe Assembly and place a 3" band clamp over the rear of this pipe). Slide the Over-Axle Assembly into the rear of the Front Pipe Assembly (or Extension Pipe if 4-door) and slip the hanger into the rubber isolation mount.
- Step 9:** Place a 3" band clamp over the rear side of the Over-Axle Assembly. Slide the Muffler Assembly into the Over-Axle Assembly and slip the hangers into the rubber isolation mounts
- Step 10:** Straighten all exhaust components and begin to tighten down all clamps beginning at the front and ending at the rear.
- Step 11:** Congratulations your exhaust is now complete. NOTE: It is recommended to re-tighten all clamps after 50-100 miles.

