



FITTING INSTRUCTIONS

Part Number: **3450450**

Product **STUBBY BAR – EXPORT ONLY**

Description:

Suited to **2018 ON JL WRANGLER 2 AND 4 DOOR MODELS**
vehicle/s:

WARNING

NOTE THE FOLLOWING:

- ◆ This product must be installed exactly as per these instructions using only the hardware supplied.
- ◆ In the event of damage to any bull bar component, contact your nearest authorised ARB stockist. Repairs or modifications to the impact absorption system must not be attempted.
- ◆ Do not use this product for any vehicle make or model, other than those specified by ARB.
- ◆ Do not remove labels from this bull bar.
- ◆ This product or its fixing must not be modified in any way.
- ◆ The installation of this product may require the use of specialized tools and/or techniques
- ◆ It is recommended that this product is only installed by trained personnel
- ◆ These instructions are correct as at the publication date. ARB Corporation Ltd. cannot be held responsible for the impact of any changes subsequently made by the vehicle manufacturer
- ◆ During installation, it is the duty of the installer to check correct operation/clearances of all components
- ◆ Work safely at all times
- ◆ Unless otherwise instructed, tighten fasteners to specified torque

ARB 4x4 ACCESSORIES

Corporate Head Office

42-44 Garden St
Kilsyth, Victoria
AUSTRALIA 3137

Tel: +61 (3) 9761 6622
Fax: +61 (3) 9761 6807

Australian enquiries
North & South American enquiries
Other international enquiries

sales@arb.com.au
sales@arbusa.com
exports@arb.com.au

www.arb.com.au

GENERAL CARE AND MAINTENANCE

By choosing an ARB Bar, you have bought a product that is one of the most sought after 4WD products in the world. Your bar is a properly engineered, reliable, quality accessory that represents excellent value. To keep your bar in original condition it is important to care and maintain it following these recommendations:



- Prior to exposure to the weather your bar should be treated to a Canuba based polish on all exposed surfaces. It is recommended that this is performed on a six monthly basis or following exposure to salt, mud, sand or other contaminants.
- As part of any Pre Trip Preparation, or on an annual basis, it is recommended that a thorough visual inspection of the bar is carried out, making sure that all bolts and other components are torqued to the correct specification. Also check that all wiring sheaths, connectors, and fittings are free of damage. Replace any components as necessary. This service can be performed by your local authorized ARB Stockist.

FITTING REQUIREMENTS

REQUIRED TOOLS FOR FITMENT OF PRODUCT:

BASIC TOOL KIT	TORQUE WRENCH(ES) 9 -> 120Nm
GRINDER WITH CUTTING DISK	MARKING PEN
BLACK TOUCH UP PAINT	300MM RULE AND TAPE MEASURE
MASKING TAPE	LOW TACK PLASTIC SHEETING
SPIRIT OR DIGITAL LEVEL	TORX SET

HAVE AVAILABLE THESE SAFETY ITEMS WHEN FITTING PRODUCT:

Protective eyewear		Hearing protection	
--------------------	---	--------------------	---

NOTE: 'WARNING' notes in the fitting procedure relate to OHS situations, where to avoid a potentially hazardous situation it is suggested that protective safety gear be worn or a safe work procedure be employed. If these notes and warnings are not heeded, injury may result.

FASTENER TORQUE SETTINGS:

SIZE	Torque Nm	Torque lbft
M6	9Nm	7lbft
M8	22Nm	16lbft
M10	44Nm	32lbft
M12	77Nm	57lbft
3/8"	44Nm	32lbft

PARTS LISTING			
APPLICATION.	PART NO.	QTY	DESCRIPTION
FIT LIGHT MOUNTS TO BUMPER	3750439R	1	LIGHT MOUNT RHS JL STUBBY
	3750439L	1	LIGHT MOUNT LHS JL STUBBY
	6151625	6	M8 X 25 TORX PC8.8 BZ480 NYL PATCH
	4584324	6	WASHER FLAT M8 BLACK
	6151548	6	NUT FLANGE M8 BLACK
FIT BUMPER TO VEHICLE	4654444	1	ASSY WELDED 3450450 JL STUBBY
	6151357	8	BOLT M10 X 1.5 SEMS
FIT WINCH, FAIRLEAD & LICENSE PLATE TO VEHICLE	3759375	1	CONTROL BOX BRACKET
	3759374	1	LICENSE PLATE MOUNT – ROLLER
	3759377	1	LICENSE PLATE MOUNT – HAWSE
	3759376	1	LICENSE PLATE HOLDER
	5846214	2	WINCH PACKER 8MM
	6151074	4	BOLT 3/8 X 1 3/4"
	6151456	4	BOLT M10x1.5x45 PC8.8 TZP
	4584361	4	WASHER M10 X 25 X 4 HV300 TZP480
	6151255	2	BOLT M12 X 1.75 X 40 PC8.8 TZP
	6151574	2	NUT NYLOC M12 X 1.75 PC8 TZP
	4581049	4	WASHER FLAT M12
	6151546	2	BOLT M8 X 1.25 X 25 BLACK
	4584324	2	WASHER FLAT M8 BLACK
	4584325	2	SPRING WASHER M8 BLACK
	6151548	2	NUT FLANGE M8 BLACK
	6151550	2	BOLT HEX HEAD M6 X 25 BLACK
	6151459	2	SCREW BTN HD M6x16 BTZP480
	4584295	6	WASHER FLAT M6 BLACK
	6151549	2	NUT M6 NYLOC BLACK
	6151561	2	NUT M6 FLANGE BLACK
5848302	2	WASHER PLASTIC M6	
FIT JACK PLUGS TO VEHICLE	3163009	2	JACK PLUGS
MISCELANEOUS	180302	4	CABLE TIE 4.8x200MM

**ASSEMBLY SEQUENCE FOR BULL BAR INSTALLATION.
PLEASE READ AND UNDERSTAND FITTING INSTRUCTIONS BEFORE
ATTEMPTING TO THE FIT BAR AND ACCESSORIES TO THE VEHICLE**



1. To fit the bulbar to the vehicle, the plastic bumper and associated hardware must be removed from the vehicle.

HINT: Apply a sheet of low-tack across the front of the vehicle's grille to avoid marking the vehicle.

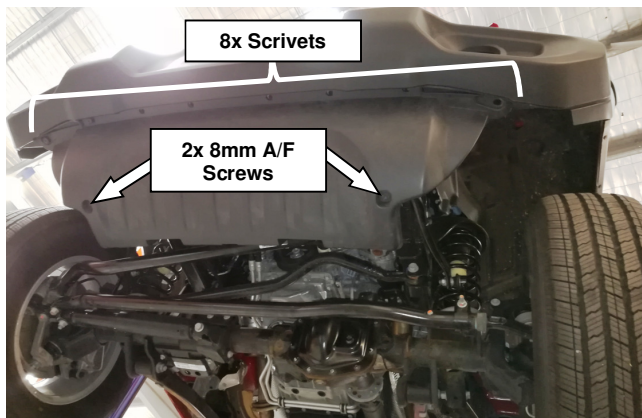

2. Remove 2x 8mm A/F Self Tapping Screws from the plastic Splash Panel below the Bumper.
Remove 8x Scrivets from the Splash Panel.
Remove the plastic Splash Panel from the vehicle and discard.



3. Remove 2x M10 SEMS from the steel Front Panel and retain for later use.

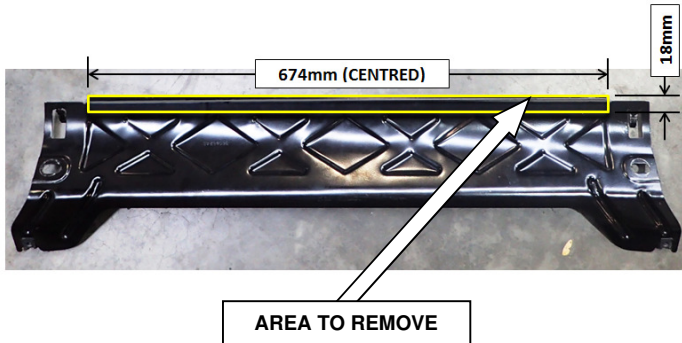

4. Remove the steel Front Panel and trim down from the top edge as shown at left



WARNING: Drilling & cutting operations can result in flying debris. Eye and ear safety protection should be worn.

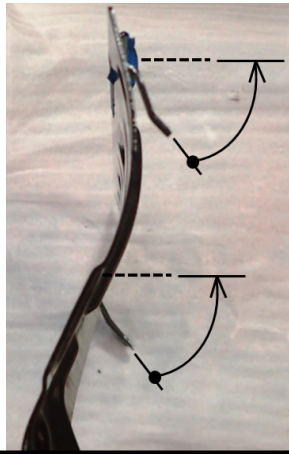

STEEL FRONT PANEL-SIDE VIEW

5. Bend both hook/tabs normal to the rear of the Panel as shown below.
6. Clean up any sharp edges or burs with a file.
7. Apply black spray paint to cut edges to prevent corrosion.



8. Disconnect fog light harness, located on the RHS chassis rail, access from inside wheel arch. Leave disconnected.

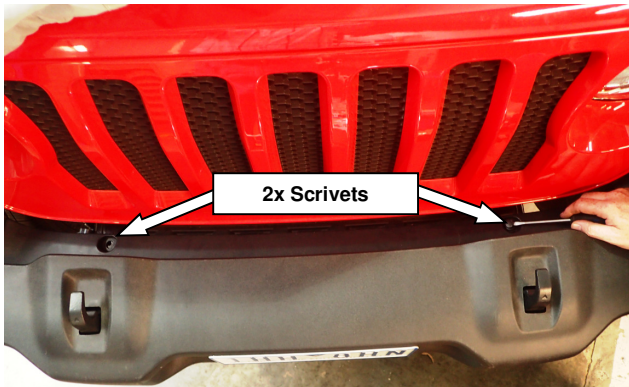

2x Scrivets

9. Remove 2x scrivets from top of bumper with flat bladed screw driver and discard.

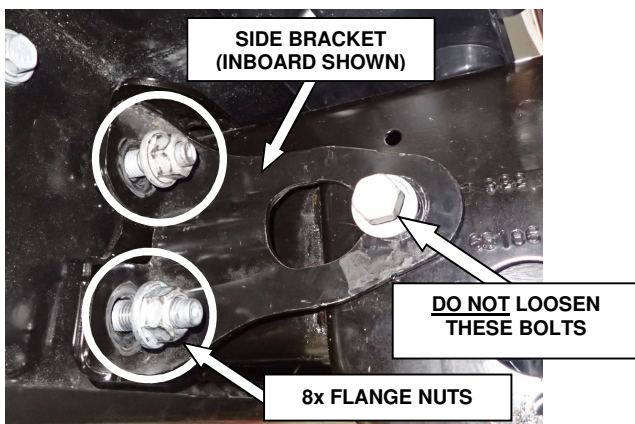
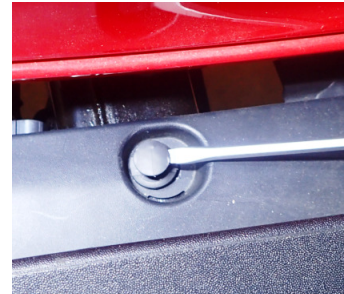

10. Remove and discard 8x flange nuts from behind front bumper (4x RHS and 4x LHS).
11. Leave the 4x OE Chassis Side Support Brackets and fasteners in place. (2x RHS and 2x LHS)



12. Remove OE Bumper and integrated steel impact beam from vehicle and discard.

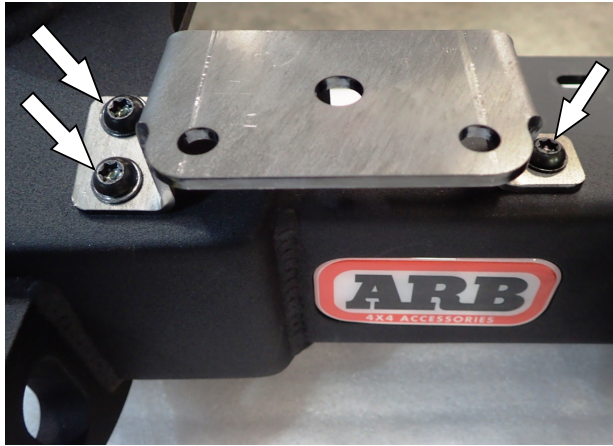

RH LIGHT BRKT SHOWN
LH OPPOSITE

13. ***If driving lights are to be fitted***, place the Bar on a flat surface with a protective covering on it, then install the RH and LH Light Brackets using a T40 Torx bit, 13mm A/F spanner and the 6x M8 fastener sets supplied.

 M8 - 22 Nm.

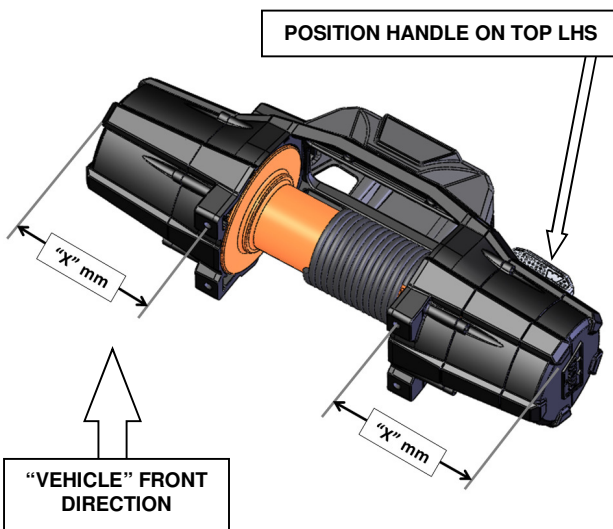

14. ***If fitting a winch***, measure the distance “X” between the centre of the nearest winch mounting hole to the end of the housing. If this distance is greater than 172mm then a notch in the chassis flange must be cut.
15. Ensure that the winch gearbox handle is positioned to the top and on the LHS when facing the vehicle and viewed from the front.
16. Warn Zeon Winch shown.

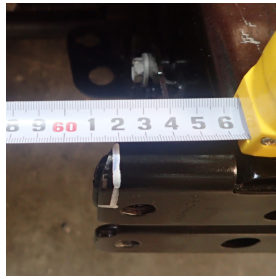

LHS SHOWN

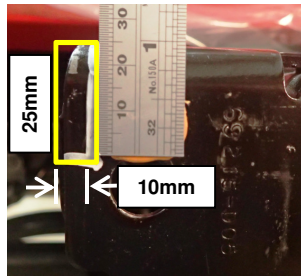

LHS SHOWN

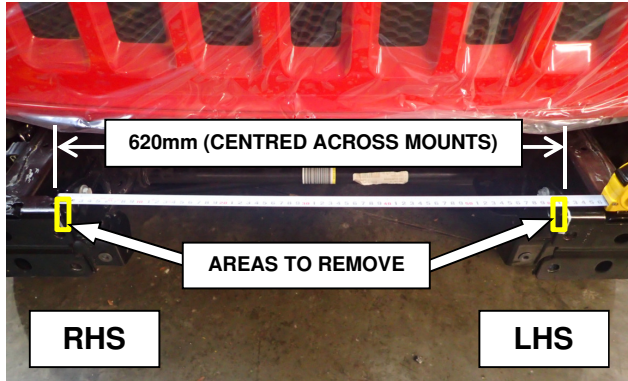

RHS

LHS

17. **For applications where a winch is not going to be fitted, go to Step 28.**

18. **For Warn Zeon Winch;**

- a. Mark local sections 10 wide x 25 down from the top inboard mount plate corners. Check that the overall width is 620mm centred across both RH and LH mounts.
- b. Carefully cut the two marked sections through both the front Chassis Mount Plate and assembled inboard Chassis Side Support Bracket using an angle grinder and cutting disc taking care not to cut into the top inboard mount holes.



WARNING: Drilling & cutting operations can result in flying debris. Eye and ear safety protection should be worn.

- c. Clean up any sharp edges or burs with a file.
- d. Apply black spray paint to cut edges to prevent corrosion.

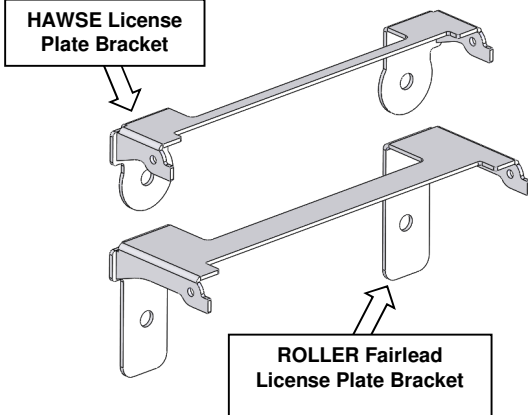

19. **If installing a License Plate and Winch** to the bar, choose whether to install the Roller Fairlead or Hawse License Plate Bracket.

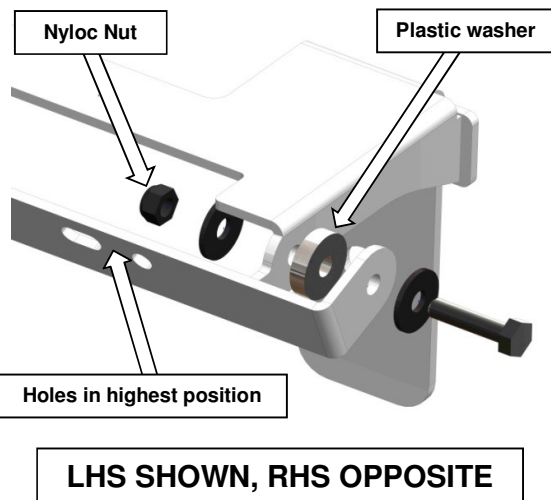

20. Assemble the pivoting License Plate Bracket sub-assembly as shown using the M6 hardware provided. Ensure that it is not overtightened so that it may pivot with a reasonable amount of friction. (**Roller Fairlead** type shown here)

 M6 - 9 Nm.



21. Install the chosen License Plate Bracket and Roller Fairlead (or Hawse) using the M12 hardware supplied. (**Roller Fairlead** type shown here)

 M12 - 77 Nm.

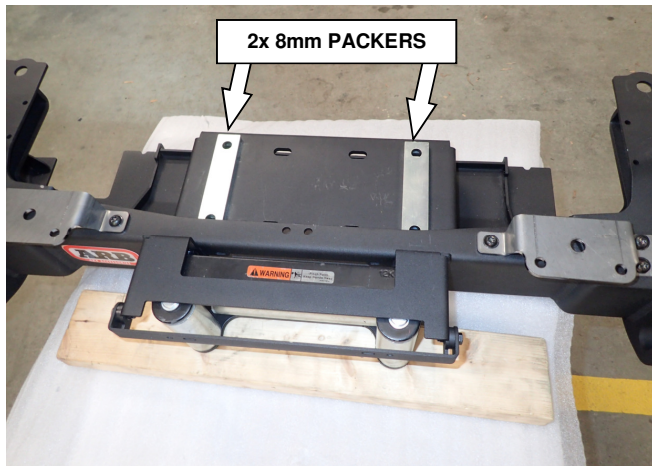

22. **For Warn Zeon Winch ONLY;**

With the Bar level, locate 2x 8mm Winch Packers over the outboard slots in the winch mount plate, one on each side as shown.

Hint: Use a 50mm thick block located under the front of the Bar to level it in preparation for mounting the winch on top. Take care not to mark the Bar.

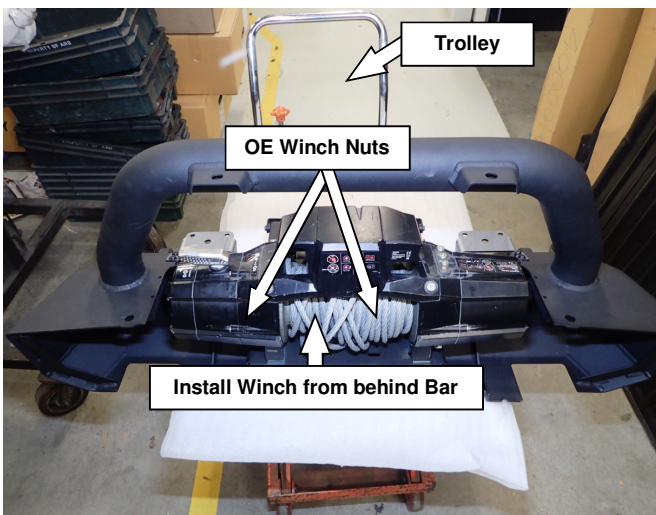

23. Install 4x OE Winch Nuts (2x Front and 2x Back) inside the mount feet of the Winch.

24. Place the winch on top of the Packers (taking care not to move them) from behind the Bar as you pass the Cable through the Fairlead (or Hawse)

HINT: Use an adjustable height Trolley with the rear of the winch oriented towards the front of the Trolley to make installing the assembled Bar onto the vehicle easier. Take care not to displace the 4x OE Winch Nuts located loosely inside the Winch housing mounts during installation.

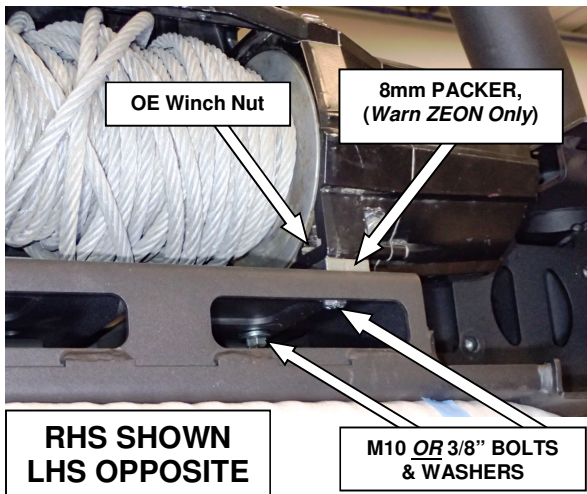

25. Secure the Winch to the Bar using either 4x Hex Head Bolt 3/8" x 1 3/4" or 4x Hex Head Bolts M10 x 1.5 x 45 and Washers supplied. Loosely tighten.

NOTE: Please consult your Winch Installation Guide for further information.

NOTE: The 2x 8mm thick Packers are only used with the Warn Zeon Winch installation.

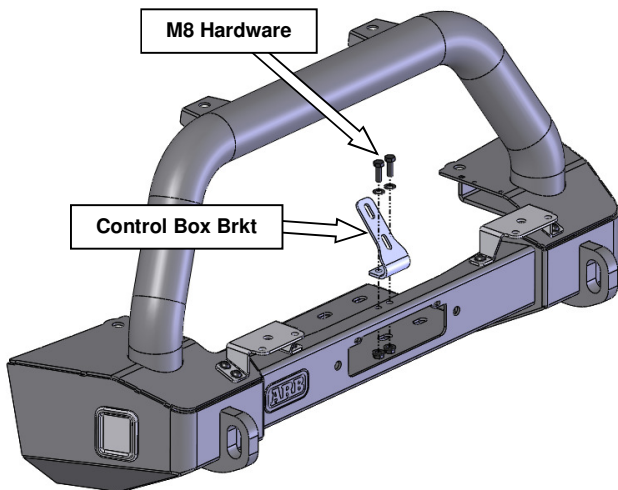

26. ***If installing a Winch with separate Control Box not mounted to the Winch***, first install the Control Box Bracket at the front of the Bar before installing the Fairlead (or Hawse) and Winch, using the 2x M8 x 25 Hex Head Bolts, Washers and Hex Flange Nuts provided as shown at left.

 **M8 - 22 Nm.**

27. Secure the Control Box to the Bracket using the Winch manufacturer's hardware.

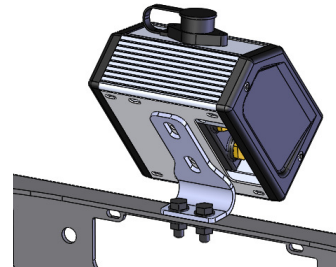

Please consult your Winch Installation Guide for further information on harness and wiring.

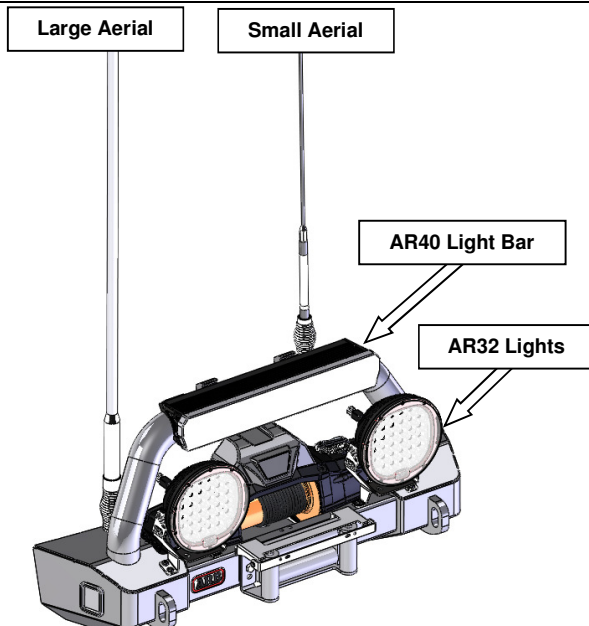

28. Install any other accessories onto the Bar such as an AR40 Light Bar, AR32 LED Driving Lights, Large / Small CB Aerials etc prior to installing the Bar assembly onto the vehicle to avoid marking the vehicle. (Accessories may also be installed later, after the Bar is fitted to the vehicle.)

NOTE: There is provision to mount a large or small aerial on the 2x CB brackets welded to the Centre Frame or in the 2x holes at the rear of the Bar top faces as shown. When selecting the location for your accessory, please ensure that adequate clearance to the vehicle is maintained (eg MIN 20mm)

Please consult the individual accessory manufacturer's installation guides for your products and related wiring information.

(Warn Zeon Winch shown)



29. With the assistance of a second person and/or height adjustable trolley, carefully position the Bar in front of the chassis mounts, taking care to route any Winch or other accessory cables around obstacles and clear of the chassis mounting faces.

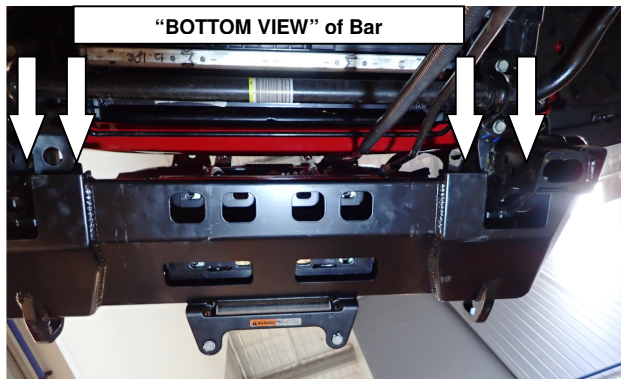

30. Secure the Bar to the mounts using 8x M10x 35 SEMS inserted through the chassis mounts from the rear into the M10 weld nuts installed on the Bar. Loosely tighten.

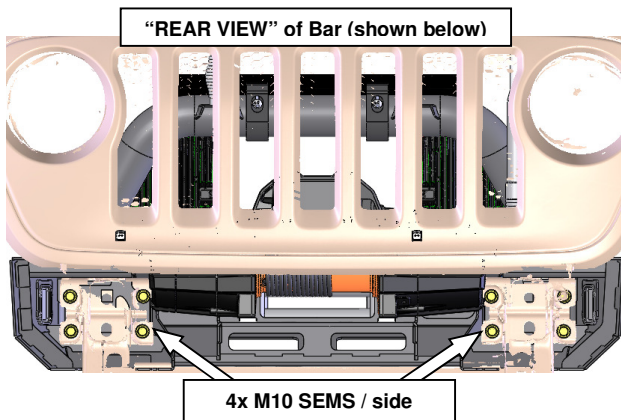



31. Check that the Bar is levelled horizontally using a spirit or digital level and that it sits centrally on the vehicle.
32. Use an extension on the Torque Wrench to access all of the securing bolts from the rear of the Bar/Chassis Mount Plates and tighten.

 **M10 - 44 Nm.**

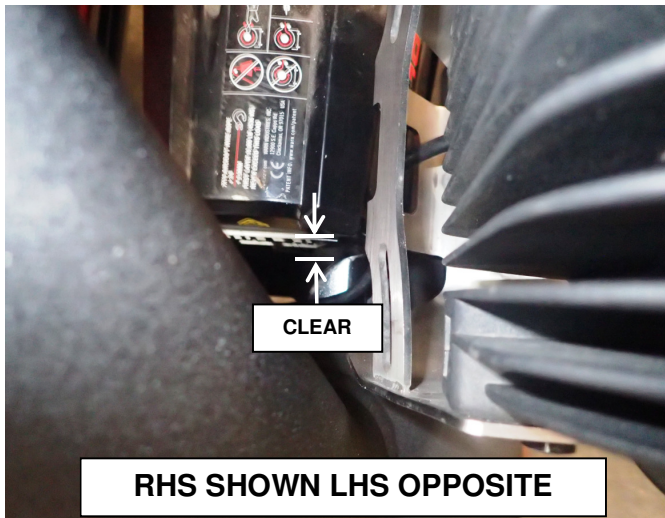

33. Check that the Winch sits clear of the chassis mounts on the RH and LH sides (Warn Zeon Winch shown)

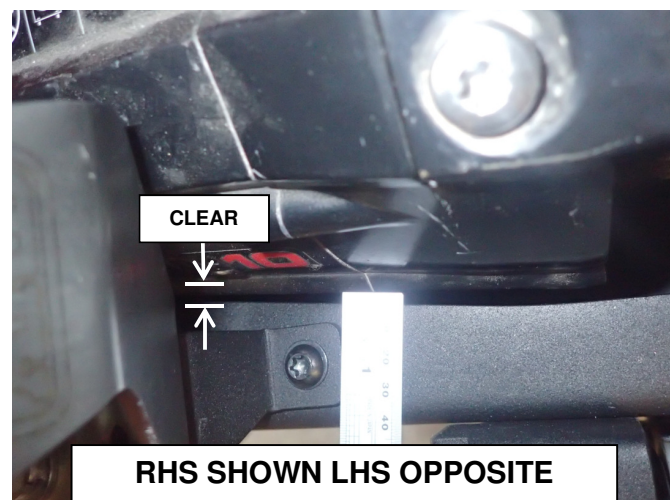

34. Check that the Winch is clear of the Bar's Top Pan profile inside the recess in which it is installed. (Warn Zeon Winch shown)
35. Tighten the 4x Hex Head Bolts 3/8" x 1 3/4" or 4x Hex Head Bolts M10 x 1.5 x 45 securing the Winch to the Bar using the Winch manufacturer's torque specification.

 **M10 or 3/8" – Manufacturer's Torque.**

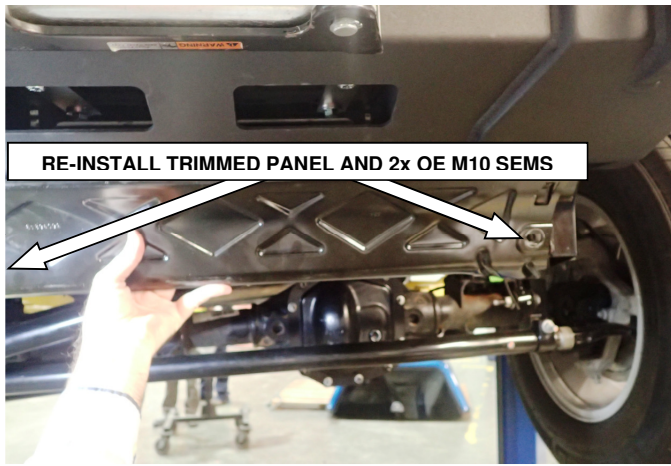

36. Install the Steel Front Panel that was removed and trimmed in Step 4 using the 2x OE M10 SEMS removed in Step 3
37. Check that all cables and wiring are adequately secured using the cable ties provide and are clear of any moving parts.
38. Remove any protective low-tack sheeting or masking tape from the vehicle



39. Install the 2x Rubber High-Lift Jack Plugs, one on each side of the Bar. LHS shown.

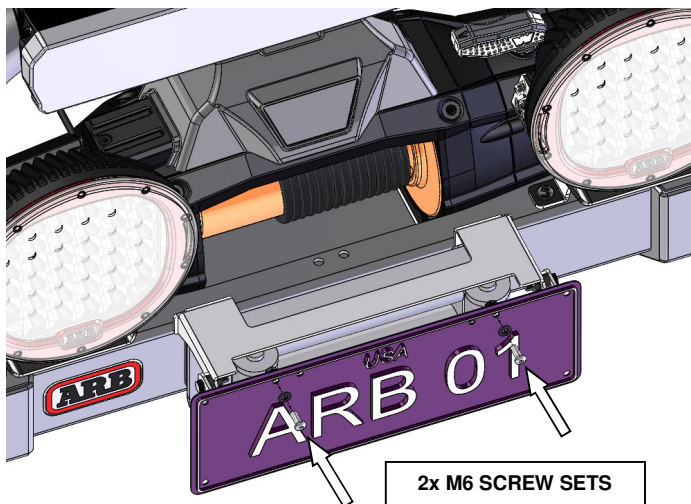

40. Install the License Plate to the Bar using the 2x M6 Button Head Screws, Washers and Hex Flange Nuts provided.

 **M6 - 9 Nm.**

FITTED PRODUCT

ONCE BAR IS FITTED:

- ◆ Ensure all bolts are tensioned correctly.
- ◆ All wiring is clear of sharp edges or moving surfaces and is secured properly.
- ◆ Any piping is secured well clear of sharp or moving components.
- ◆ Check operation of winch if fitted.
- ◆ Check all wiring and connections to turn signal lamps, sensors, headlamp washers etc. are functioning correctly.