



Installation Instructions



Factory Style Bow Kit



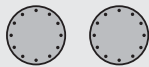

Vehicle Application:

- Jeep Wrangler JK 2 Door
- 2007 – Current
- Part Number: 55000

Compatible with original equipment soft tops, 54722 Supertop NX and 79142 Sailcloth Replace-A-Top

www.Bestop.com - We're here to help! Visit our web site and click on "[Ask a Question](#)". Click here for more [Jeep® Accessories by Bestop](#).

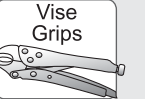
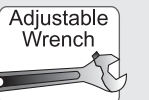
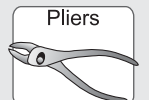
INSTALLATION TIME	SKILL LEVEL
 2 Hours	 2 - Moderately Easy

TOOLS			
 Power Drill #2 Phillips Bit	 Phillips Screwdriver #1, #2, #3	 Torx Wrench T30	 Vise Grips
 Adjustable Wrench	 Pliers	 Masking Tape	 Safety Glasses



 **CAUTION** Safety glasses should be worn at all times while installing this product.

 **WARNING** This product is designed primarily to enhance the appearance of the vehicle and to shield the occupants from ordinary weather conditions. Do not rely in any way on the components of this product to contain occupants within the vehicle, or to protect against injury or death in the event of an accident. This product will not protect the occupants from falling objects. Never operate the vehicle in excess of manufacturer's specifications.

WEAR SEAT BELTS AT ALL TIMES

Read and follow, precisely, all installation instructions provided when installing product. Failure to do so may result in a poor fit and could place occupants of the vehicle in a potentially dangerous situation.

Factory Style Bow Kit Installation Instructions

Parts List and Hardware Identification

Parts List:

- Bow Mount Bracket - Right, Qty - 1, Part Number 482.88
- Bow Mount Bracket - Left, Qty - 1, Part Number 482.89
- Rear Bow Leg - Left, Qty - 1, Part Number 486.54
- Door Rail - Left., Qty - 1, Part Number 479.81
- Door Rail - Right., Qty - 1, Part Number 479.82
- Screw, Qty - 4, Part Number 532.23
- Rear Bow - Center, Qty - 1, Part Number 486.54
- Rear Bow Leg - Right, Qty - 1, Part Number 486.54
- #2 Bow Assembly, Qty - 1, Part Number 459.30
- Front Top Arch, Qty - 1, Part Number 486.55
- Tailgate Bar, Qty - 1, Part Number 489.46
- Side Bow- Right, Qty - 1, Part Number 486.52
- Side Bow- Left, Qty - 1, Part Number 486.53
- Tailgate Bar Mount-Right, Qty - 1, Part Number 488.46
- Lower Header Assembly, Qty - 1, Part Number 539.60
- Tailgate Bar Mount-Left, Qty - 1, Part Number 488.47
- Edge Protector, Qty - 1, Part Number 481.90
- Upper Header Assembly, Qty - 1, Part Number 480.00

Hardware Identification:

- #8 x 1/2" Self-Drill Screw, Qty - 2, Part Number 312.09
- #8 x 1/2" Pan Head Washer Screw, Qty - 23, Part Number 393.79
- Bow Mount Screw, Qty - 4, Part Number 308.64
- M5 x 30 Machine Screw, Qty - 2, Part Number 308.87
- Bushing, Qty - 4, Part Number 473.40
- M5 Lock Nut, Qty - 2, Part Number 308.62
- #8 x 1/2" Hi-Lo Screw, Qty - 27, Part Number 459.03

Factory Style Bow Kit Installation Instructions

1 Install Bow Mount Brackets on Sport Bars

Unzip the sport bar cover, if equipped.
Use Bow Mount Screws to install Bow Mount Brackets on rear sport bar.

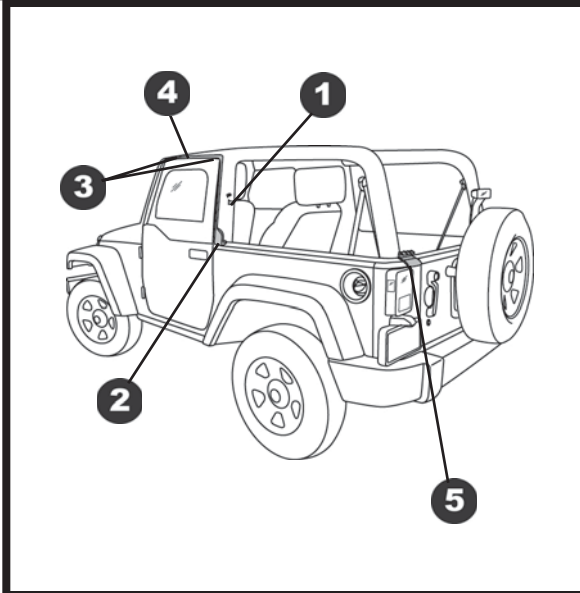
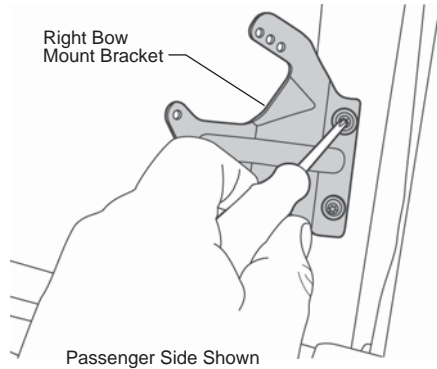

4 Install Top Arch

Insert one end of the Top Arch in to the slot in the middle of one of the Front Door Rails. Push the other end inward to flex the bow and insert it into the slot on the other side of the vehicle.

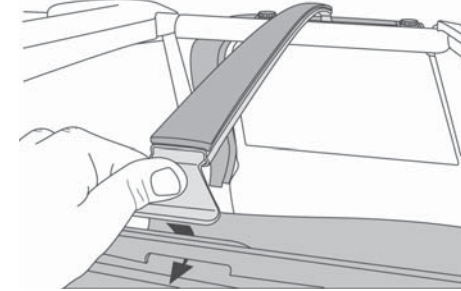

2 Install Door Rails

Locate the left and right Door Rails. Insert the pin in the bottom of the Door Rail into the hole in the belt rail behind the door.

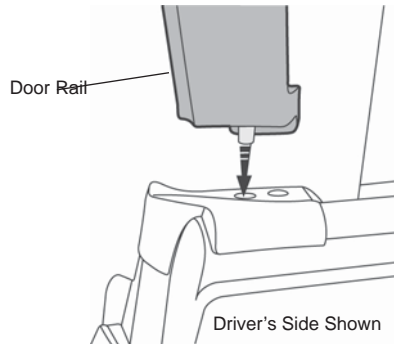

3 Secure Door Rail

Press the channels along the top of the Door Rail around the horizontal sport bar, above the door opening. Insert two Screws into the Door Rail and tighten them down to 55in/lbs (4.5in/lbs).

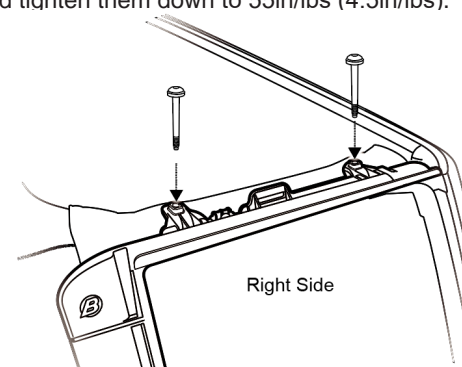

5 Install Tailgate Bar Mounts

Locate the left and right Tailgate Bar Mounts. Orient them on the vehicle. Hook the bottom of one mount under the belt rail and roll it toward the inside of the vehicle until it clips into place. Repeat this with the other Tailgate Bar Mount.

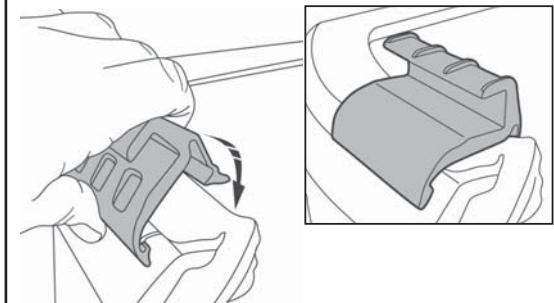

Factory Style Bow Kit Installation Instructions

6 Mount Side Bows to Header Assembly

Place the Lower Header on the Side Bows. Orient the Side Bows with the Brackets toward the inside. Install two (2) #8 x 1/2" Pan Head Washer Screws to secure the Lower Header to each Side Bow.

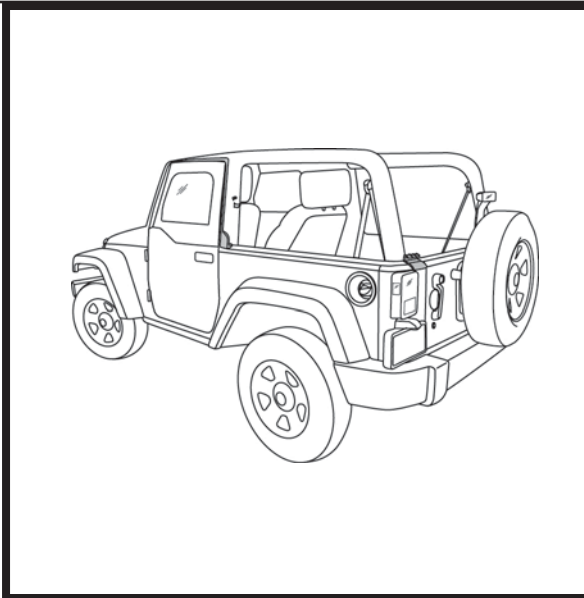
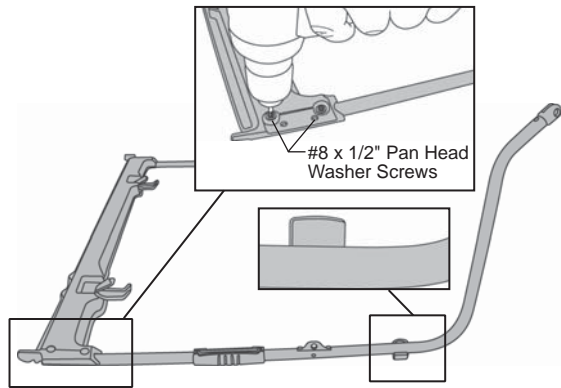

CAUTION Do Not allow Stay Pad to twist.

9 Install Stay Pad

Place the Rear Bow Assembly with the Header/Center Bow Assembly. Pull the end of the fabric stay pad to the corner of the Rear Bow. Install three (3) #8 x 1/2" Pan Head Washer Screws.

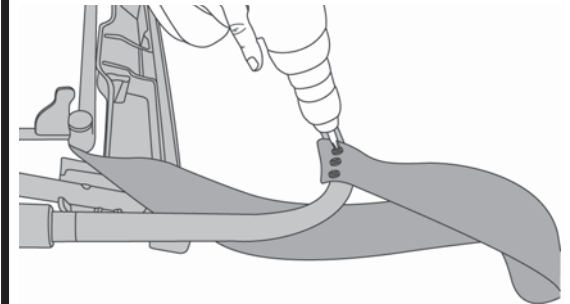

7 Assemble Center Bow to Header / Side Bow Assembly

Locate the Center Bow Assembly. Place it on the Side Bow/Header Assembly so that the fabric stay pads on the corners go toward the rear.

Install an M5 x 30 Machine Screw with two (2) Bushings and an M5 Lock Nut.

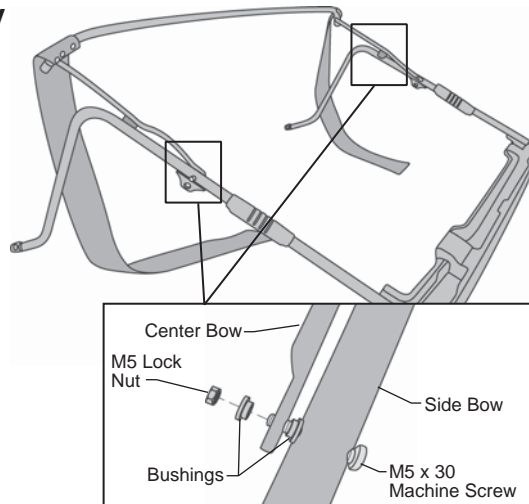

8 Mount Side Bows to Rear Bow

Locate the left and right Rear Bow Legs and orient them with the pivot knuckle knobs to the outside. Mount them to the Rear Bow Center section with a #8 x 1/2" Self Tapping Screw on each side.

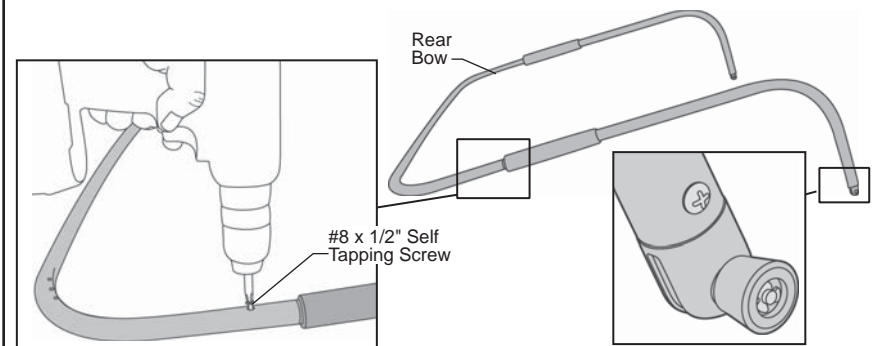

Factory Style Bow Kit Installation Instructions



CAUTION

Drill Hole in fabric and notch in Lower Header must be aligned.

10 Align Top Fabric with Header

Lay the front edge of the top fabric on the Lower Header with the backing side up. Make sure the drill hole in the center of the fabric lines up with the notch in the Lower Header. Tape the fabric in place.

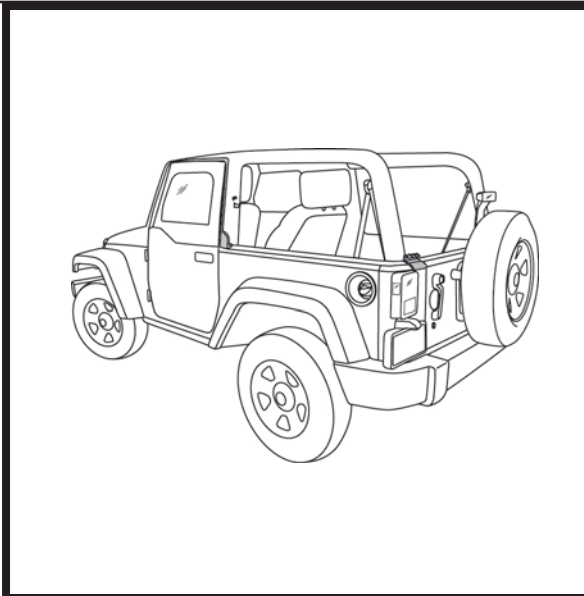
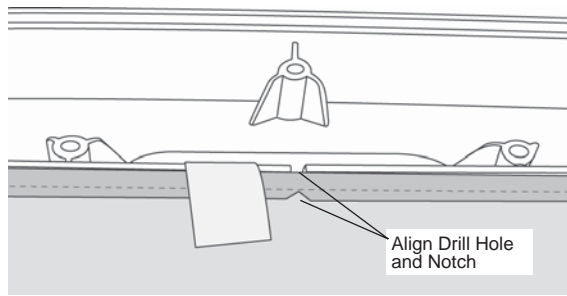

13 Secure Cable Spring

Secure Cable Spring to bracket on bow and crimp spring.

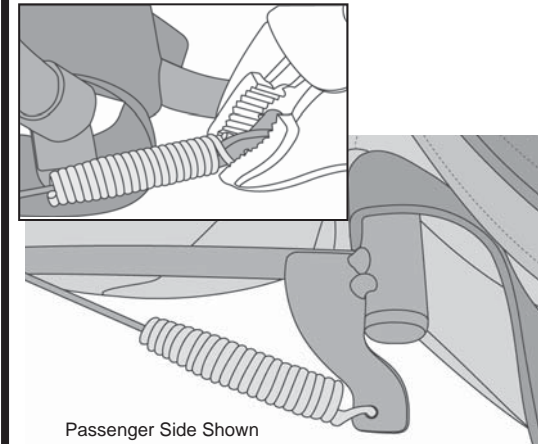

11 Secure Top Fabric to Header

Place Edge Protector over front edge of Upper Header and tape in place.

Lay the Upper Header on top so that the fabric is sandwiched between the Upper and Lower Headers.

Start with the center hole and install twenty-three (23) #8 x 1/2" Hi-Lo Screws to attach the Upper Header to the Lower Header. Secure the Upper Header to each Side Bow with four (4) #8 x 1/2" Pan Head Washer Screws.

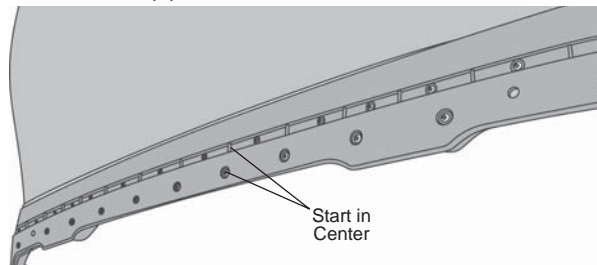

12 Install Side Bows on Header Assembly

Wrap the fabric around the edge of the header. Slip the fabric pocket sewn into the top between the headers and position the anchor foot.

Install two (2) #8 x 1/2" Hi-Lo Thread Screws through the fabric and metal flag into the Lower Header on each side.

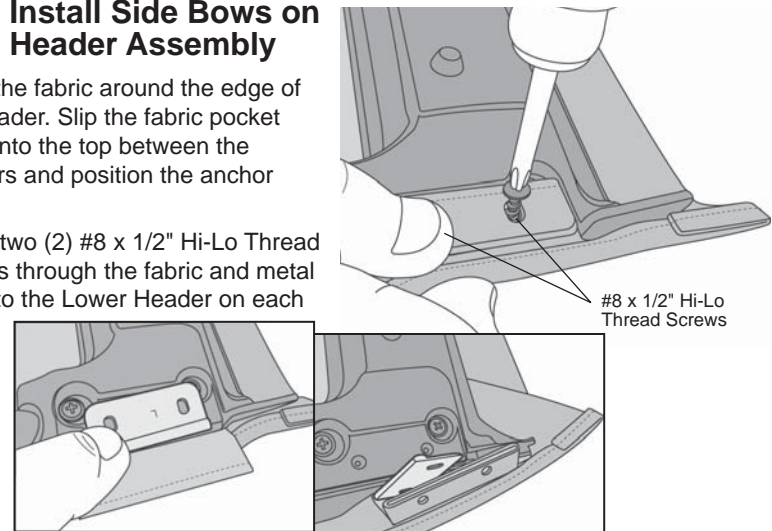

Factory Style Bow Kit Installation Instructions

14 Install Foam Tape on Header

Install Foam Tape on Header.

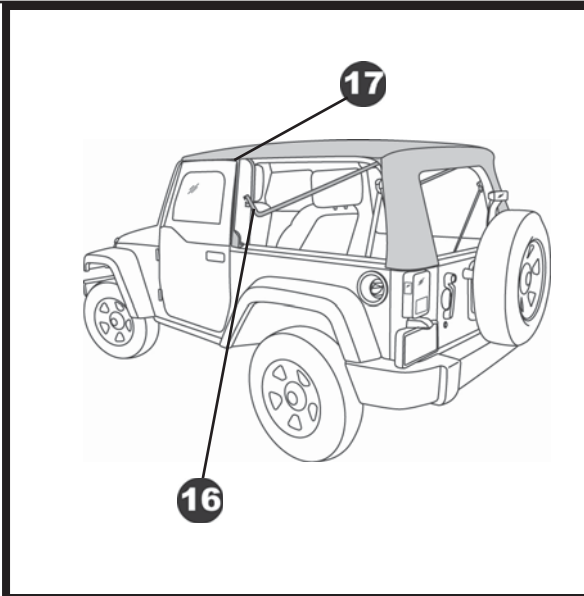
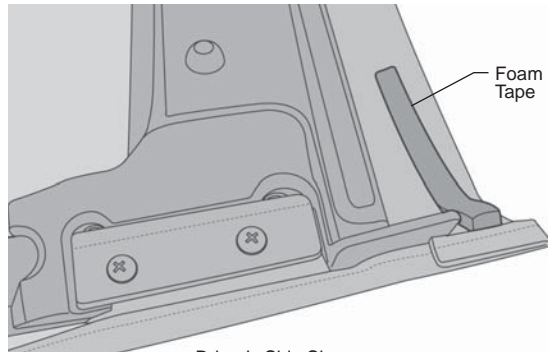

17 Drape Top Fabric Assembly over Vehicle

Open the Top Assembly and drape it over the cab of the vehicle. Push in on the Sunrider lock lever and lock the Side Bow to the Door Surround.

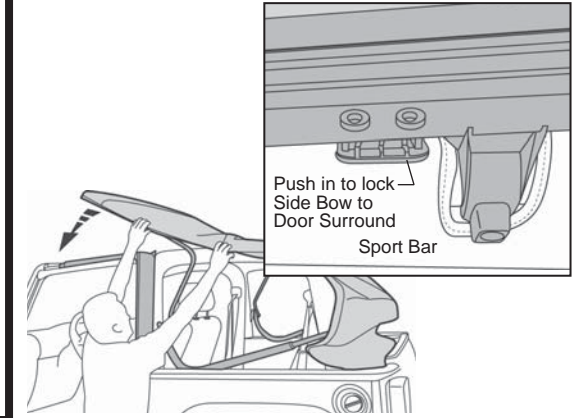

15 Install Foam Seal on Header

Install Foam Seal on Header.

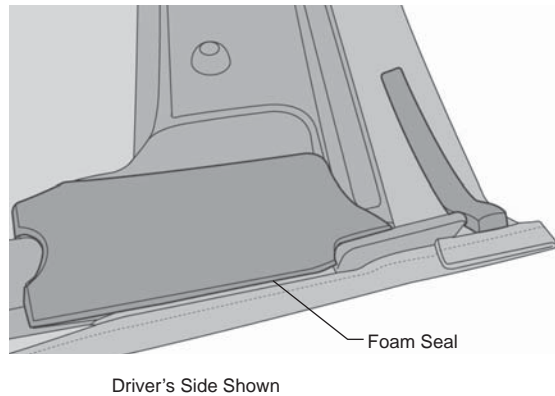

16 Secure Top Fabric Assembly to Bow Mount Bracket

Place the top assembly on the back of the vehicle. Clip the Side Bow pivots into the lower Bow Mount Bracket hole. Clip Rear Bow pivots into the front upper Bow Mount Bracket hole. If the top becomes loose the Rear Bow can be moved to a rearward hole to tighten the top.

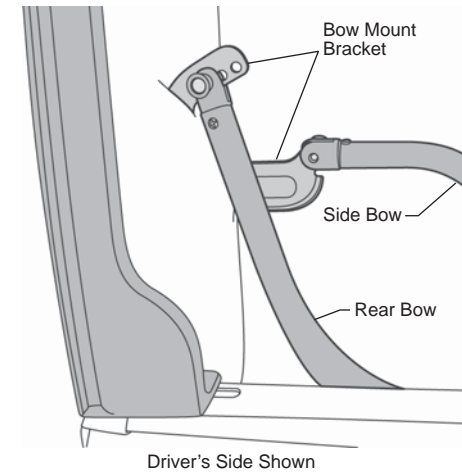

Factory Style Bow Kit Installation Instructions

18 Secure Top Fabric to Rear Bow

Once the top is in place, locate the four (4) flaps sewn inside the top above the rear window opening. Install a #8 x 1/2" Pan Head Washer Screw to secure each flap to the Rear Bow.

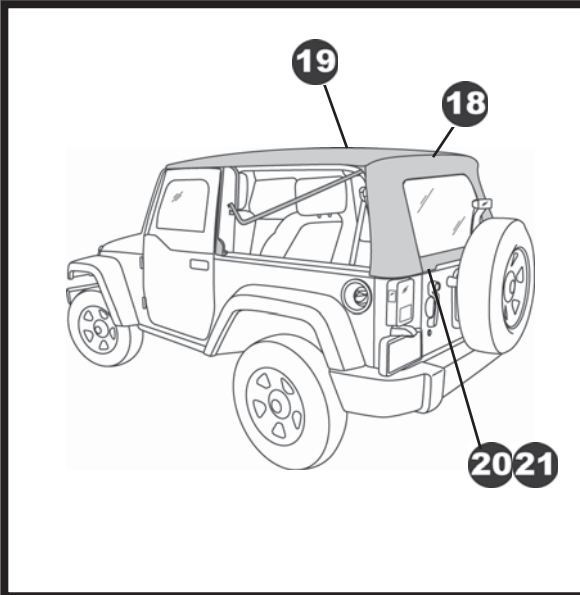
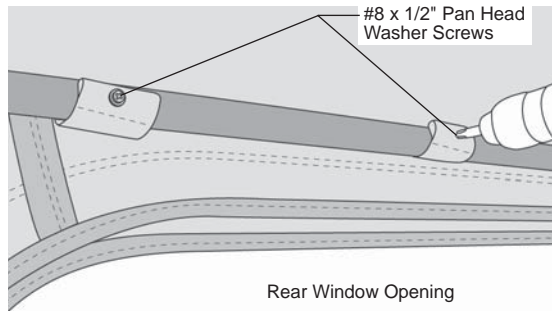

21 Secure Tailgate Bar

Slide the Tailgate Bar into the Tailgate Bar Mounts on each side of the tailgate opening.

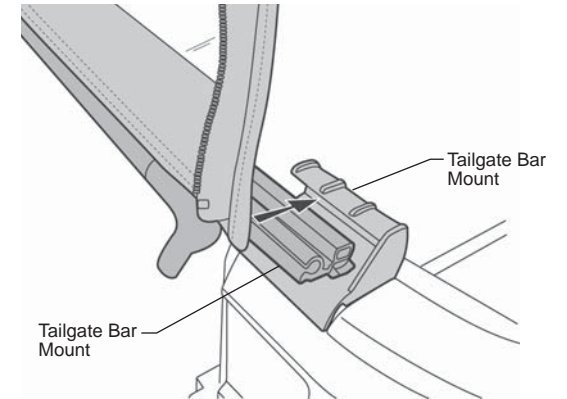

19 Secure Top Fabric to Center Bow

Locate the flaps inside the top in the center. Wrap them around the bow and install five (5) #8 x 1/2" Pan Head Washer Screws.

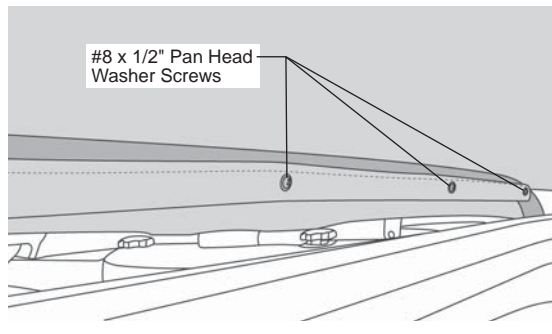

20 Install Tailgate Bar

Slide the channel in the Tailgate Bar onto the tubing along the bottom of the Rear Window on the inside.

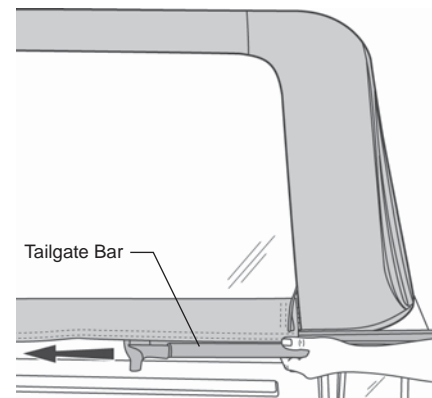



BESTOP WARRANTY SUMMARY

Updated July 2017



WHAT BESTOP WARRANTS

Subject to the terms and conditions of sale, including any terms and conditions set forth by Bestop, Inc. ("Bestop" or "us" or "we") in our then-current terms of sale on our website (collectively, the "Terms"), Bestop represents and warrants that: the covered products listed in the "Covered Products and Warranty Periods" section (a "Product") will substantially be free from defects in materials and workmanship for the specified warranty periods set forth in that section.

THE WARRANTY IS LIMITED AND CONDITIONAL

This warranty applies to the original purchaser of the Product only. The warranty is valid only as long as the original retail purchaser owns the vehicle upon which the Product is installed. The warranty expires should the Product be removed from the original vehicle or if the original vehicle is transferred to another owner. This warranty is not transferable or assignable. The warranty does not apply to Product bought from auction-style or price-bid websites.

THE LIMITED WARRANTY AND STATED REMEDIES ARE SOLE AND EXCLUSIVE AND IN LIEU OF ALL OTHER WARRANTIES AND REMEDIES, AND COMPANY EXPRESSLY DISCLAIMS ALL IMPLIED OR STATUTORY OR OTHER WARRANTIES, INCLUDING WITHOUT LIMITATIONS WARRANTIES OF MERCHANTABILITY, NON-INFRINGEMENT, MERCHANTABILITY OR FITNESS FOR A PARTICULAR PURPOSE. IN NO EVENT WILL COMPANY BE LIABLE FOR ANY SPECIAL, INCIDENTAL, CONSEQUENTIAL, PUNITIVE, INDIRECT OR EXEMPLARY DAMAGES OF ANY KIND, INCLUDING LOST PROFITS OR REVENUE, HOWEVER CAUSED, WHETHER FOR BREACH OR REPUDIATION OF CONTRACT, TORT, BREACH OF WARRANTY, NEGLIGENCE, OR OTHERWISE, WHETHER OR NOT COMPANY WAS ADVISED OF THE POSSIBILITY OF SUCH LOSS OR DAMAGES.

Some states do not allow exclusion or limitation, so this may not apply to you. This warranty gives you specific legal rights, and you may have other rights which vary from state to state.

EXCLUSIONS TO THE WARRANTY

The Limited Warranty excludes, and Bestop is not liable in any way for any warranty claims, damages, or defects related to:

- Misuse, abuse, accidents, vandalism, negligence, fire, or improper installation or modification, or improper or inadequate maintenance;
- Failure to comply with any Product documentation, Bestop instructions, or applicable law or regulations; use in extreme conditions
- Force Majeure including but not limited to, earthquake, hurricane, tornado, flooding, or other disasters natural or man-made, civil unrest, strikes, declared or undeclared war, or lack of performance by, or discontinued product of, supply chain partners whose products, software, operations or management is beyond the control of Bestop;
- Damage resulting in breakage (including without limitation, spontaneous breakage, accidental breakage or breakage by any other means) of a Product or any component part;
- Damage to vinyl windows due to misuse, or cracking due to varying weather conditions.

YOUR SOLE REMEDY

During the applicable warranty period, Bestop shall, at its option, either repair or replace any Product that it confirms, in its discretion, is non-compliant with the warranties herein. Bestop will not pay for labor charges associated with installation or removal of the Product. Should a specific Product be discontinued, Bestop may, at its option, replace the discontinued Product with a current product or like product. If Bestop opts to repair or replace your Product as set forth herein, Bestop shall use reasonable efforts to match any patch or replacement to the color and texture of your existing Product. There is no guarantee however, that Bestop will be able to match the color or texture. If Bestop is not able to match the color or texture, it may provide you with a black or neutral colored patch replacement in its discretion.

Please retain your proof of purchase. Original proof of purchase for the Product must accompany any warranty claim. If you have a warranty claim, first you must email Bestop Customer Service at csbestop@bestop.com for instructions. All claims must be emailed to csbestop@bestop.com within 30 days of discovery of a defective Product, but in no event later than thirty days after the end of the applicable Warranty Period (the "Warranty Notice Period"). Warranty claims made after the Warranty Notice Period are null and void and Bestop shall have no responsibility with respect to such claims.

THIS SECTION SETS FORTH BESTOP'S SOLE OBLIGATION & YOUR SOLE REMEDY WITH RESPECT TO ANY DEFECTS OR OTHER PRODUCT ISSUE. ANY PRODUCTS REPLACED UNDER TERMS OF THIS WARRANTY WILL BE COVERED UNDER TERMS & BALANCE OF THE DURATION OF THE ORIGINAL LIMITED WARRANTY FOR SUCH PRODUCT.

COVERED PRODUCTS AND WARRANTY PERIODS: The warranty time periods are as follows for Products manufactured by Bestop:

BESTOP® LIMITED LIFETIME WARRANTY

Trektop® Pro Twill Fabric Top	Sunrider® for Hardtop Twill Fabric Top
Trektop® NX Glide Twill Fabric Top	Replace-a-Top™ Twill Fabric Top
Trektop® NX Twill Fabric Top	Supertop® NX Twill Fabric Top
EZFold™ Soft Tonneau	Floor & Cargo Liners
ZipRail™ Soft Tonneau	Pet Barriers
EZRoll™ Soft Tonneau	

BESTOP® 5-YEAR LIMITED WARRANTY

Trektop® NX Glide™ Top (non-Twill)	Sunrider® for Hardtop (non-Twill)
Replace-a-Top™ Top (non-Twill)	Trektop® NX Top (non-Twill)
Sailcloth Replace-a-Top™	Supertop® NX Top (non-Twill)
TigerTop™ and HalfTop™	Supertop® Classic Soft Top
Sunrider® Complete Soft Top	Supertop® for Truck
EZ Fold Hard Tonneau	

BESTOP® 3-YEAR/100K MILES LIMITED WARRANTY

Powerboard® & Powerboard® NX
Trekstep®, Side Mount
Trekstep®, Rear Mount

BESTOP® 3-YEAR LIMITED WARRANTY

Pavement Ends Sprint Top

BESTOP® 2-YEAR LIMITED WARRANTY

Trektop® Classic Soft Top
RoughRider™ Soft Storage

BESTOP® 1-YEAR LIMITED WARRANTY

All other Bestop® & Pavement Ends™ products not specified above.
--