



DECKED Storage System



Installation Instructions: MJ1

JEEP GLADIATOR 5' BED LENGTH

(2020-CURRENT)

TOOLS REQUIRED

- 3/8" socket
- short 7/32" hex wrench
- 1/8" hex wrench
- 7/16" socket
- Torx 45 driver
- 10" socket extension



SCAN ME

REGISTER YOUR SYSTEM



SCAN ME

INSTRUCTION VIDEOS

Watch short installation videos at www.decked.com/video | Register your system at www.decked.com/warranty

FOLLOW US: @DECKEDUSA | #DECKEDUSA

VERSION 7

DECKED.COM | 208.806.0251

CONTENTS

DECKED carton

- LEFT deck half - 1
- RIGHT deck half - 1
- Center vert - 1
- Cabside vert - 1
- Drawer - 2
- Left ammo can - 1
- Right ammo can - 1
- Ammo can lid - 2
- Left stud - 1
- Right stud - 1
- C-channel - 2
- Ruler - 1
- Hardware box - 1
- Torsion brace - 1

Hardware box - unbagged components

(inside DECKED carton):

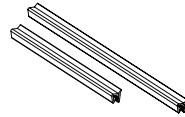

Weather strips - 2

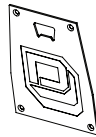

Bottle opener - 1

HARDWARE box - bagged components

- PREP MJ1 - 1
- S1 - 1
- N1 - 1
- J7C - 2
- DRAWER 1 - 1
- DRAWER 2 - 1
- WHEELS - 1
- FINAL MID - 1
- PREP-EXTRA - 1
- WASHERS - 1
- BED TAPE MJ1 - 1
- SHIM-JEEP SCRAMBLER - 1

ASSEMBLY OVERVIEW

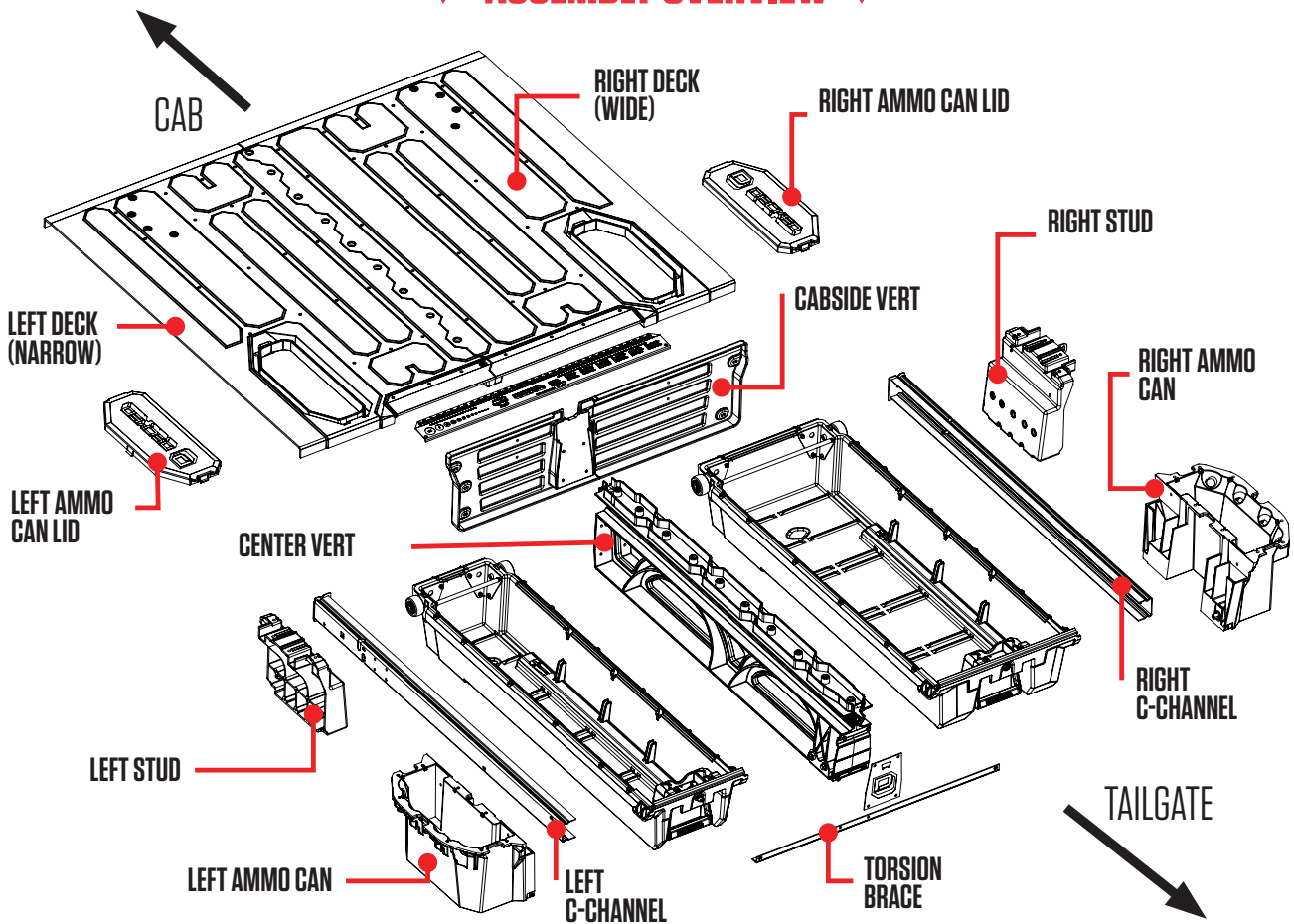

Need Help? Watch our installation videos or call us. We're happy to help!

DECKED.COM/VIDEO

▼ HEY! TORQUE BOY: READ BEFORE YOU INSTALL DECKED ▼

1. **DON'T** go rogue on us, please read the instructions.
2. **DON'T** over tighten bolts, get em' hand-tight.
3. **DON'T** use power tools.
4. If you don't follow directions and do use power tools:
 - 1). Set clutch at a very low setting.
 - 2). If you blow it: Two extra threaded inserts are included in **BAG PREP-EXTRA**. That's all you get, unless you call us and ask for more. The inserts will replace any stripped inserts in the tailgate ammo cans and studs or front face of the center vert at the bottle opener, but **NOT THE TOP OF THE CENTER VERT**, so hand tighten until snug only! You can also screw the inserts back in if dislocated. There is a straight screwdriver slot on the underside of the threaded insert.
5. Start all bolts with fingers to avoid cross-threading.
6. **DON'T** over tighten J-hooks during installation. Just get 'em good and snug; enough to keep the system from moving in the bed.
7. You will have leftover washers – you're welcome.
8. Nice job if you're still reading .

Prevent embarrassing, expletive-filled language, watch our detailed installation video or give us a call. We're happy to help!

208.806.0251 | DECKED.COM/INSTALLVIDEO

AMMO CAN DRAIN HOLES

(TO DRILL OR NOT TO DRILL.)

• Do you use a tonneau or shell over your DECKED system?

There is no need to drill holes, unless you leave your tonneau open in a deluge.

• Does your DECKED system live outside?

The ammo cans will get water in them. You'll need to drill holes in the ammo cans.

There are two dimples in the bottom of each ammo can. Drill a 1/2" hole at each dimple. A smaller hole will get clogged.

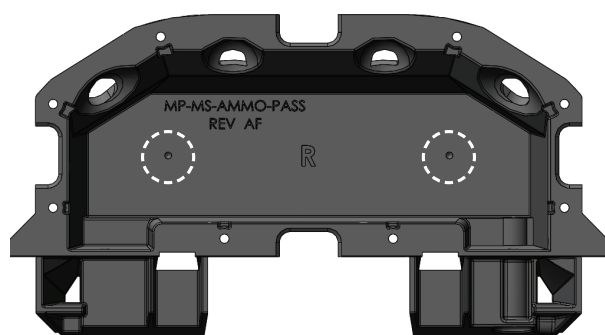
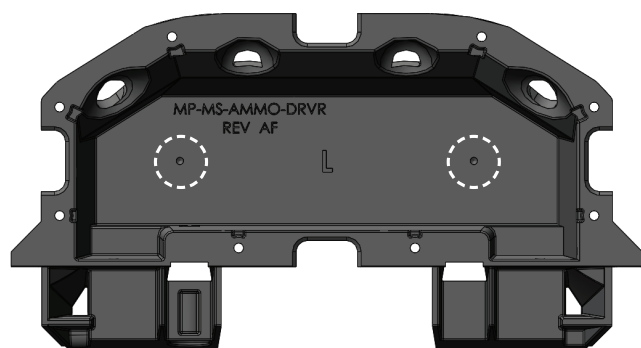

PREPARE BED: INSTALL BED TAPE

To protect your paint: **INSTALL THIS TAPE BEFORE YOU INSTALL YOUR DECKED SYSTEM**

- You will not need this tape if you have a spray-in bed liner, Bedrug or mat.
- There is a strip of protective tape provided: **BAG BED TAPE MJ1**.
- Clean the surfaces where the protective tape will be located - isopropal alcohol is recommended.
- Cut the tape strip into 7" lengths. Apply to locations in **DETAIL A** and repeat for the right side.

DETAIL A

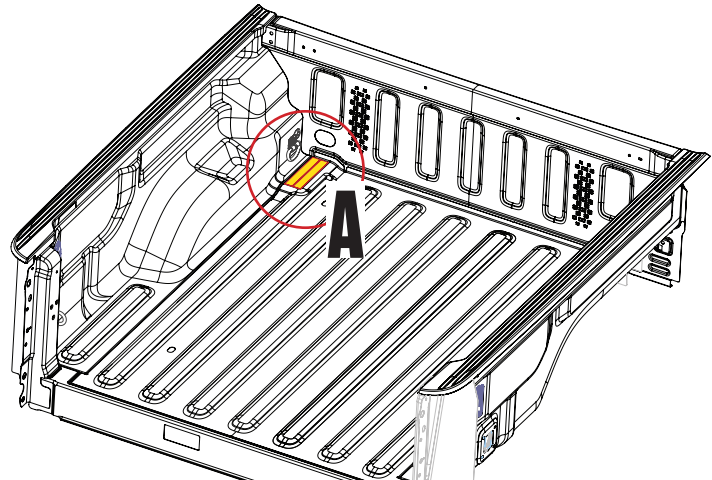
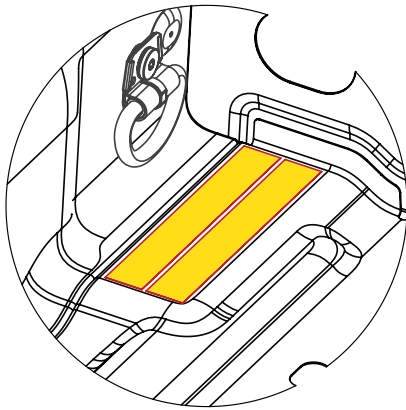

PREPARE BED: MARK CENTER OF BED

- Using a tape measure, locate centerline of bed floor (blue), which may be raised or depressed.
- Use a marking pen or wax pencil to mark the centerline on shim.
- Mark centerline on cabside panel.

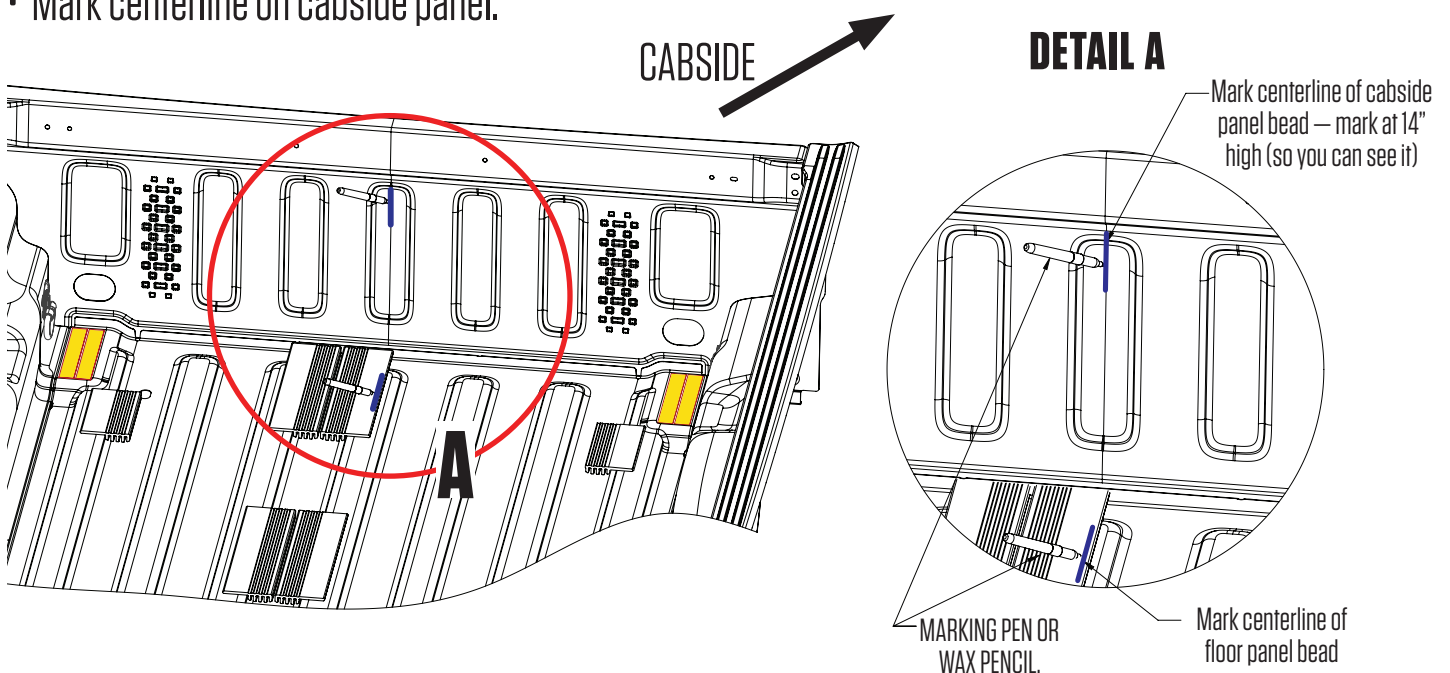

PREPARE BED: INSTALL SHIMS

- There are **12 SHIMS** provided: **BAG SHIM-JEEP SCRAMBLER**.
- Using the information in the respective circular detail views:
- Clean the surfaces where the shims will be located (isopropyl alcohol is recommended).
- Remove the layer of tape on the bottom of the shim to expose the adhesive surface.
- Place the shim and apply with pressure.

6" LONG SHIM

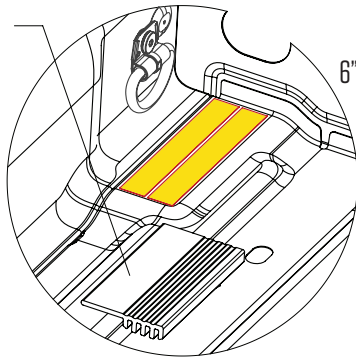

DETAIL A

6" shims - Place as shown. Repeat on right side, but opposite of left shim shown.

12" LONG SHIMS

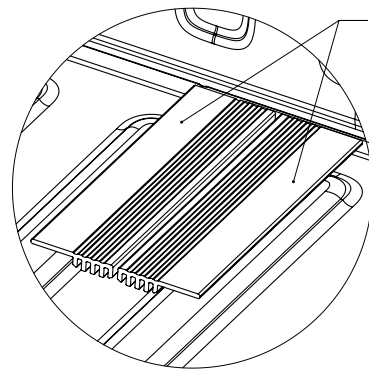

DETAIL B

Place front of shims against cabside panel of bed.

6" LONG SHIM

16" LONG SHIMS

12" LONG SHIMS

CABSIDE

TAILGATE

6.13" between shims

6" LONG SHIM

16" LONG SHIMS

16" LONG SHIMS

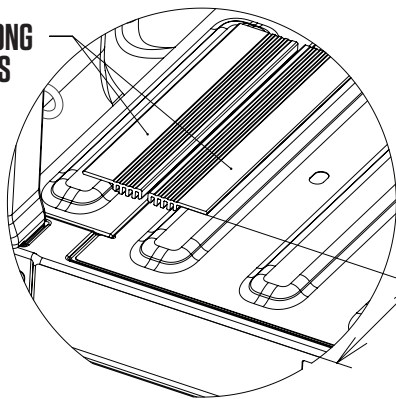

DETAIL C

16" shims - Place 7 1/2" from rear of shims to rear of bed. Repeat on right side.

12" LONG SHIMS

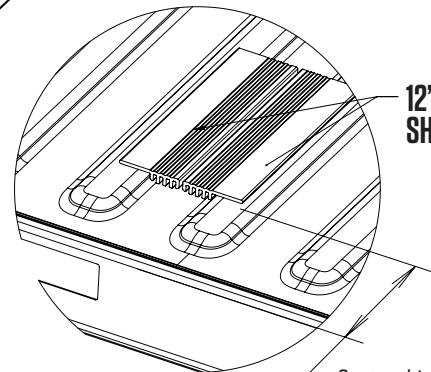

DETAIL D

Center shim between floor beads shown. Place 6 1/2" from rear of shim to rear of bed.

PREP BED: CABSIDE TIE DOWNS

(LET'S DO THIS!)

- Using a Torx T45 bit, remove screw from cabside tie down ring and remove ring.
- Set aside screw and ring; they will not be reused.
- Repeat process for opposite side cargo ring.

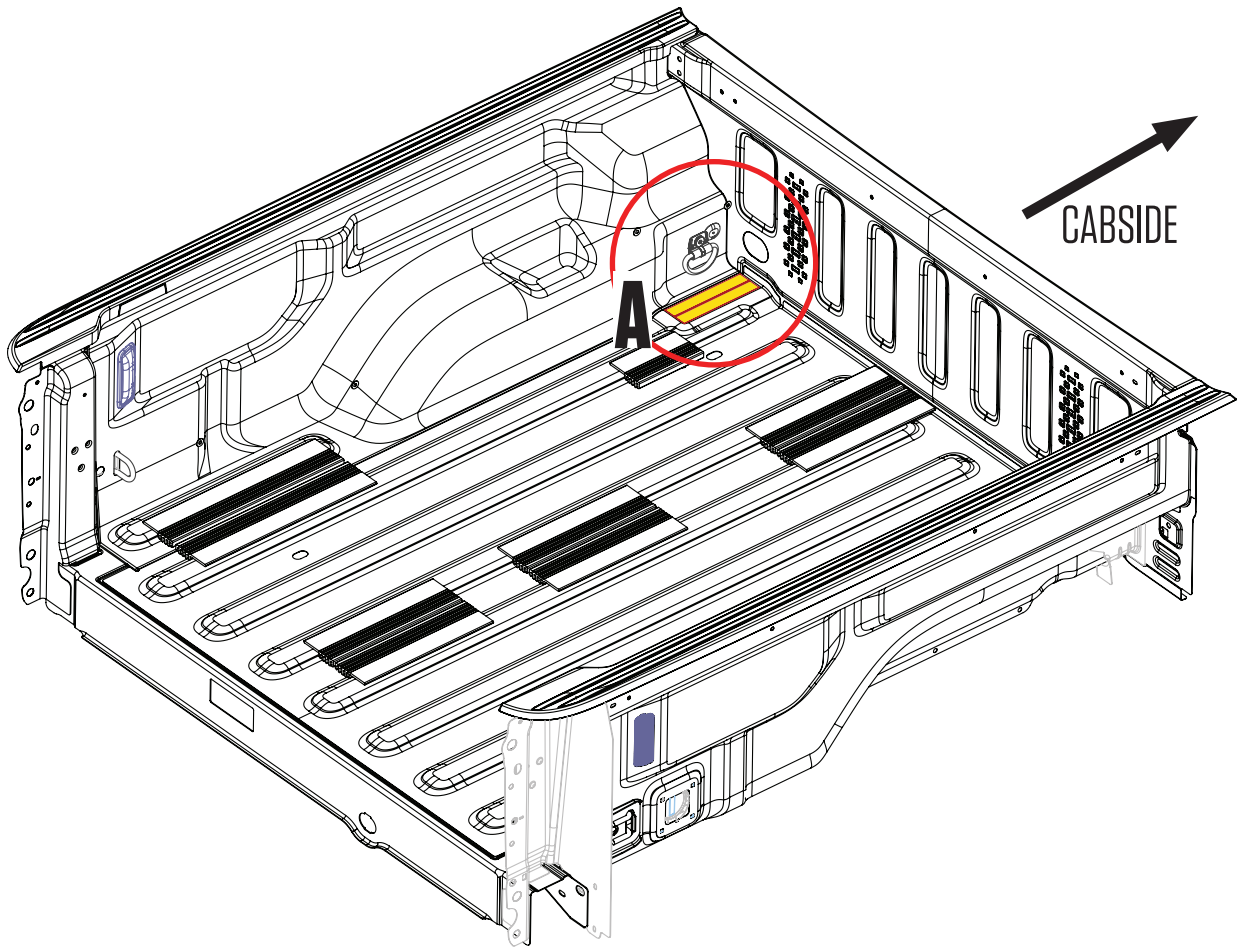

DETAIL A

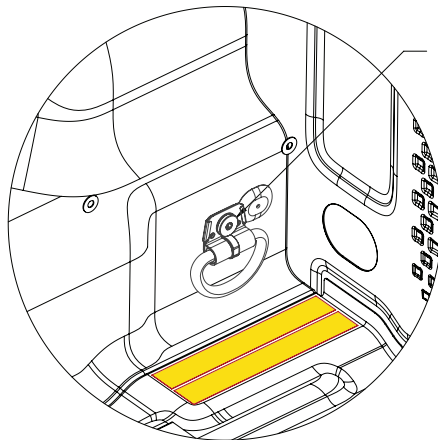

Remove Torx head screw with T45 bit.

PREP BED: CABSIDE TIE DOWNS

(NOW YOU'RE ACTUALLY GETTING SOMEWHERE!)

- Install u-nuts onto cabside mounting brackets in the direction shown; **BAG PREP MJ1**.
- Install bedside mounting bracket with 1" Torx 45 screw, using T45 Torx bit; **BAG PREP MJ1**.
Verify bracket orientation is as shown.
- Tighten securely.
- Repeat this sequence for the passenger side cabside mounting bracket.

RECOMMENDED TORQUE:
Bolts in labeled bag PREP MJ1 - 11 Ft-lb.

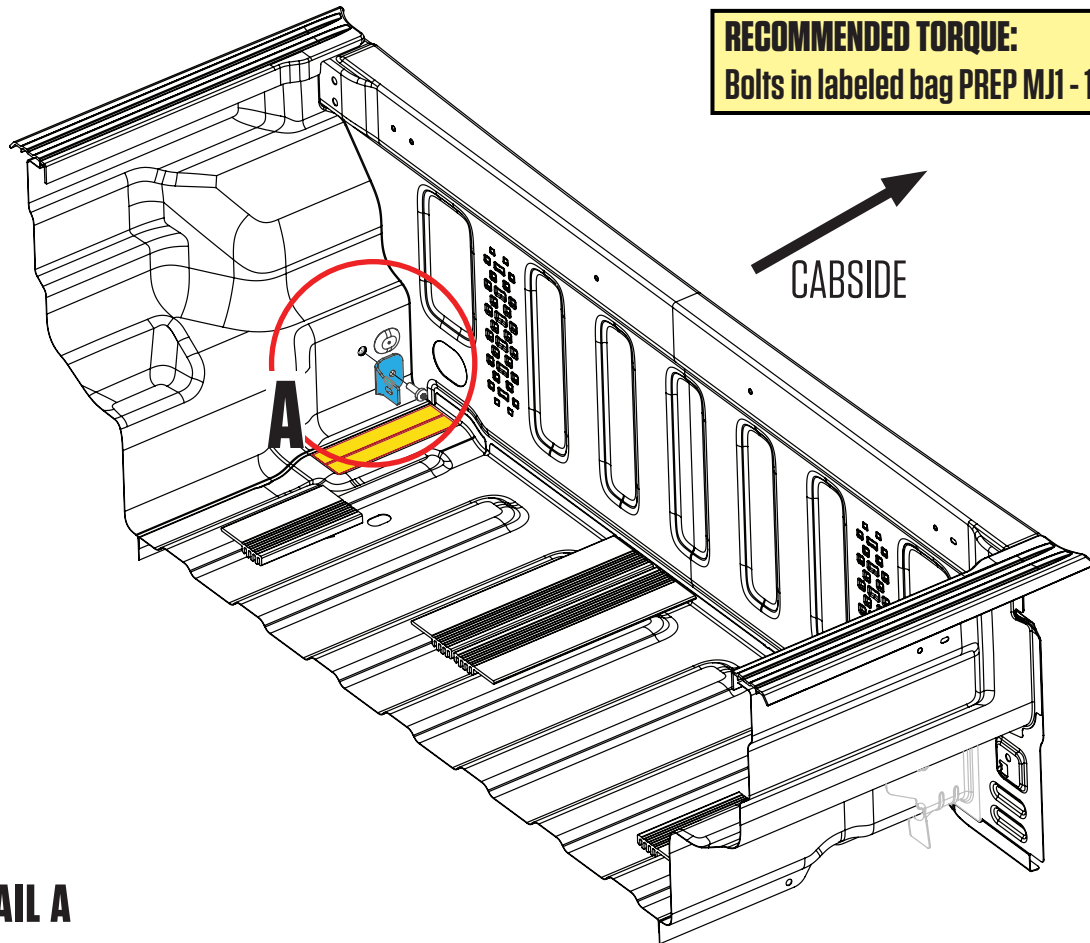

DETAIL A

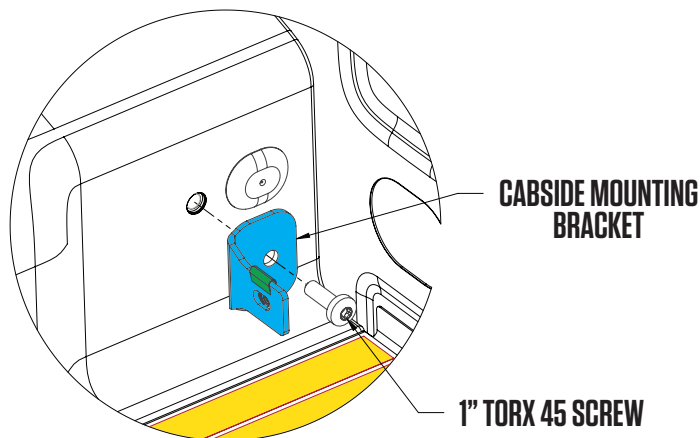

U-NUT

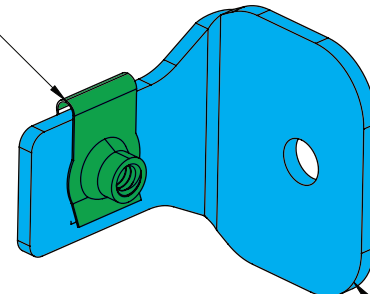

BRACKET

ASSEMBLY: CENTER VERT + CABSIDE VERT

NOTE: Perform the next few steps on a flat surface.

- Attach center vert to cabside vert with four bolts. Alternate to tighten; BAG S1.

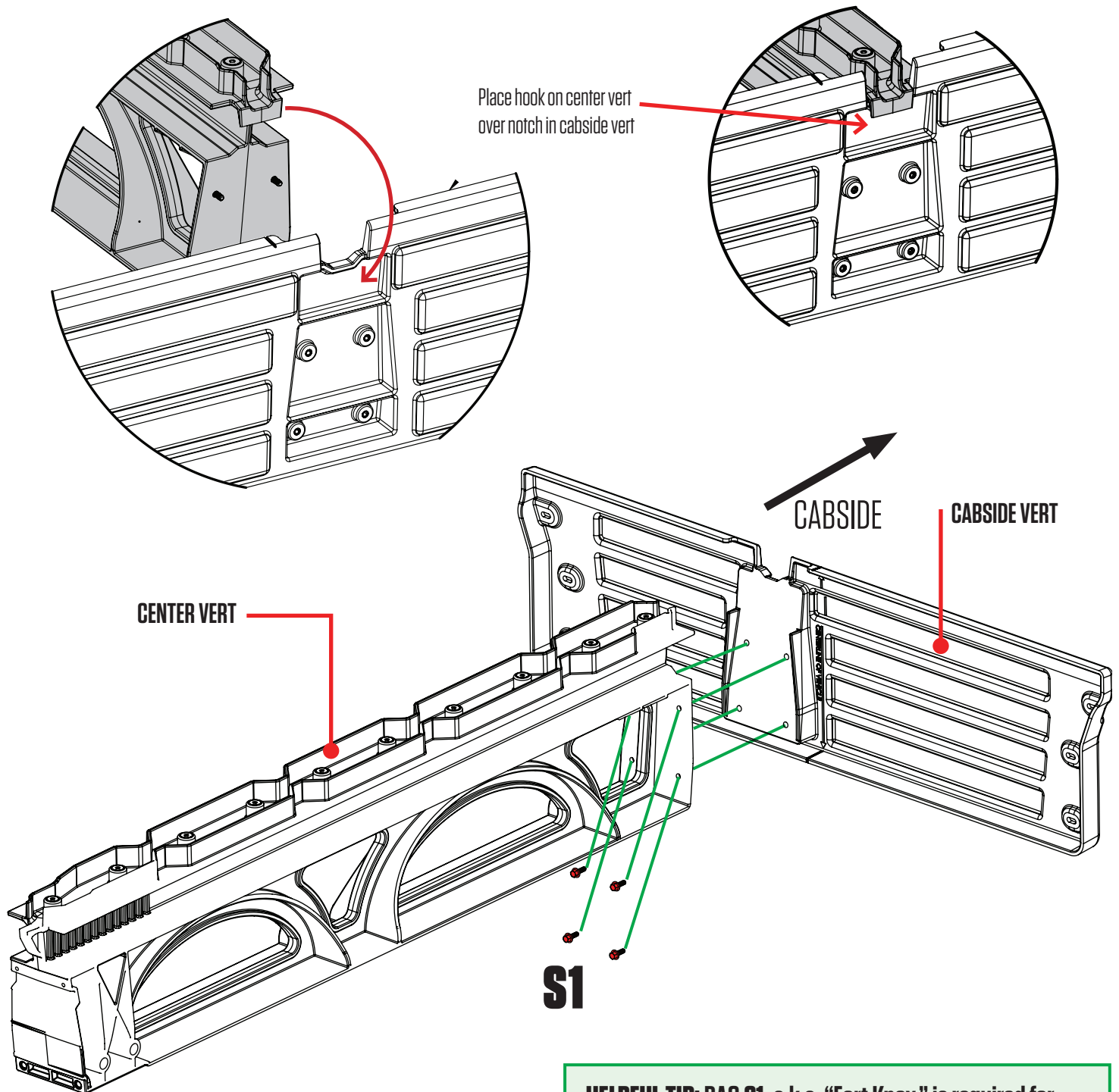

RECOMMENDED TORQUE:
 .905" bolts in bag S1 - 27 in-lb.

HELPFUL TIP: BAG S1, a.k.a. "Fort Knox," is required for most steps, so keep it close. These bolts are highlighted throughout instructions in **RED**.

ASSEMBLY: LOOSELY ATTACH STUDS

- **LOOSELY** attach studs to cabside vert with six bolts; BAG **S1**.

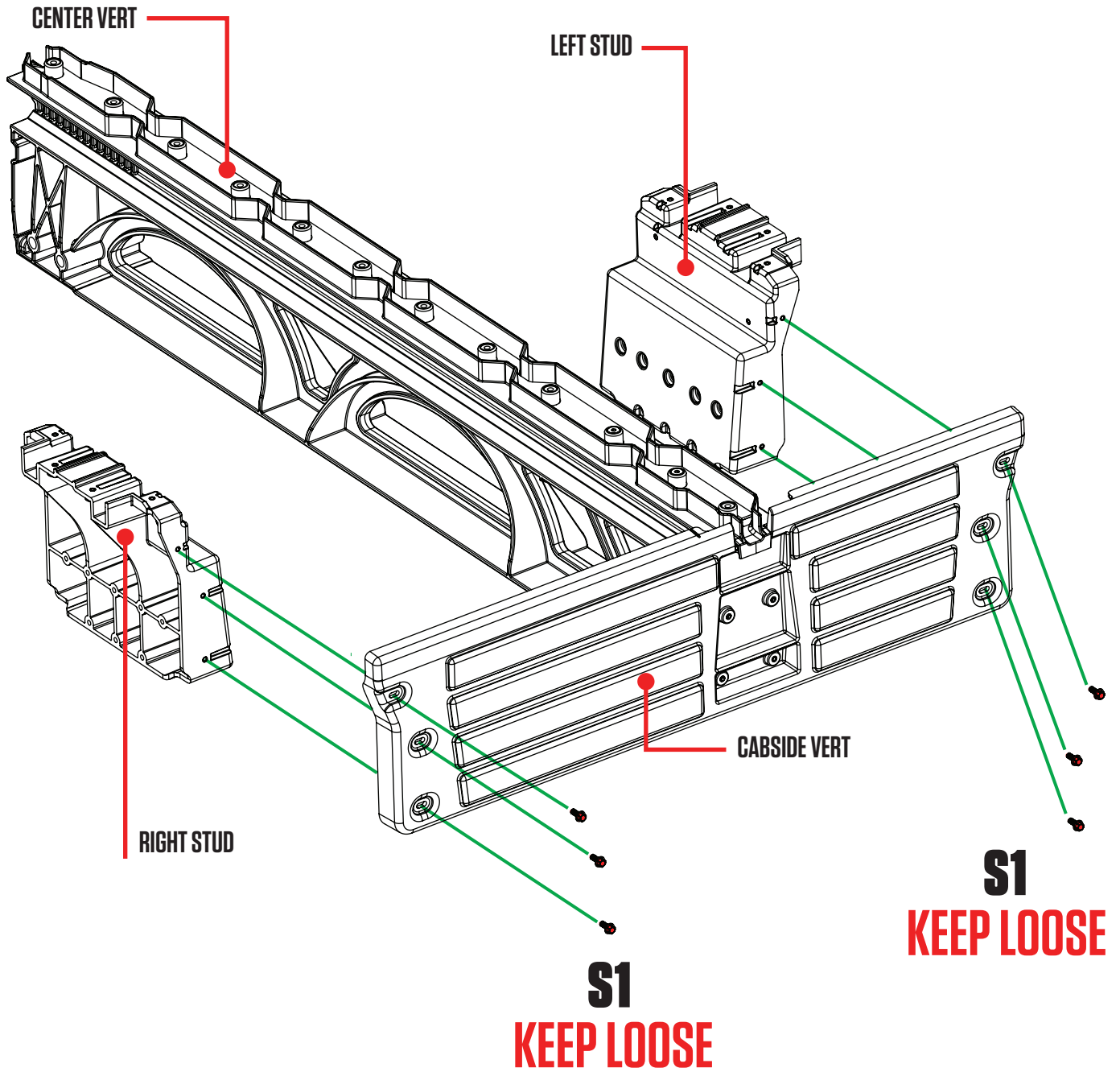

ASSEMBLY: ALIGN & TIGHTEN STUDS

NOTE: This step ensures the studs are properly located before tightening bolts. It's important.

- Place ammo cans to support tailgate end of deck panels.
- Lift deck panels on center vert + stud + cabside vert assembly.
- Slide studs around L-R until deck panels are seated.
- **DETAIL A:** Loosely secure four bolts to hold decks onto studs; **BAG S1.**
- Now you can securely tighten the bolts that hold the studs to the cabside vert.
- Unbolt deck from studs, remove deck panels, save bolts, remove ammo cans and set aside for later assembly.

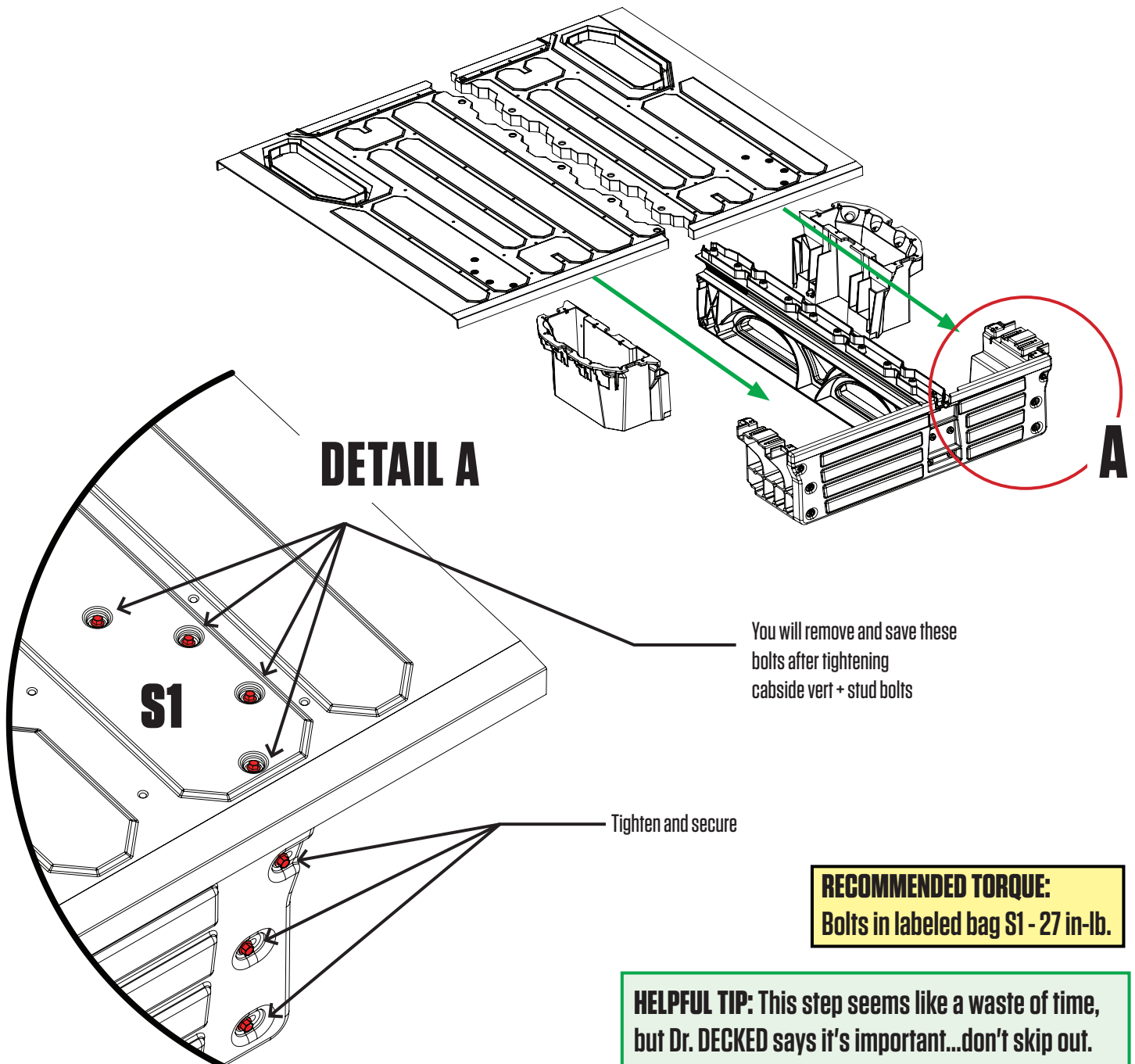

ASSEMBLY: STUD BRACKETS

- Per **DETAIL A**, attach stud bracket to left stud using (2) 3.5" bolts and (2) nuts, **BAG PREP MJ1**, making note of the proper hole locations.
- Verify orientation as shown. Repeat on right side.
- Tighten nuts securely.

RECOMMENDED TORQUE:
Bolts in labeled bag PREP MJ1 - 27 in-lb.

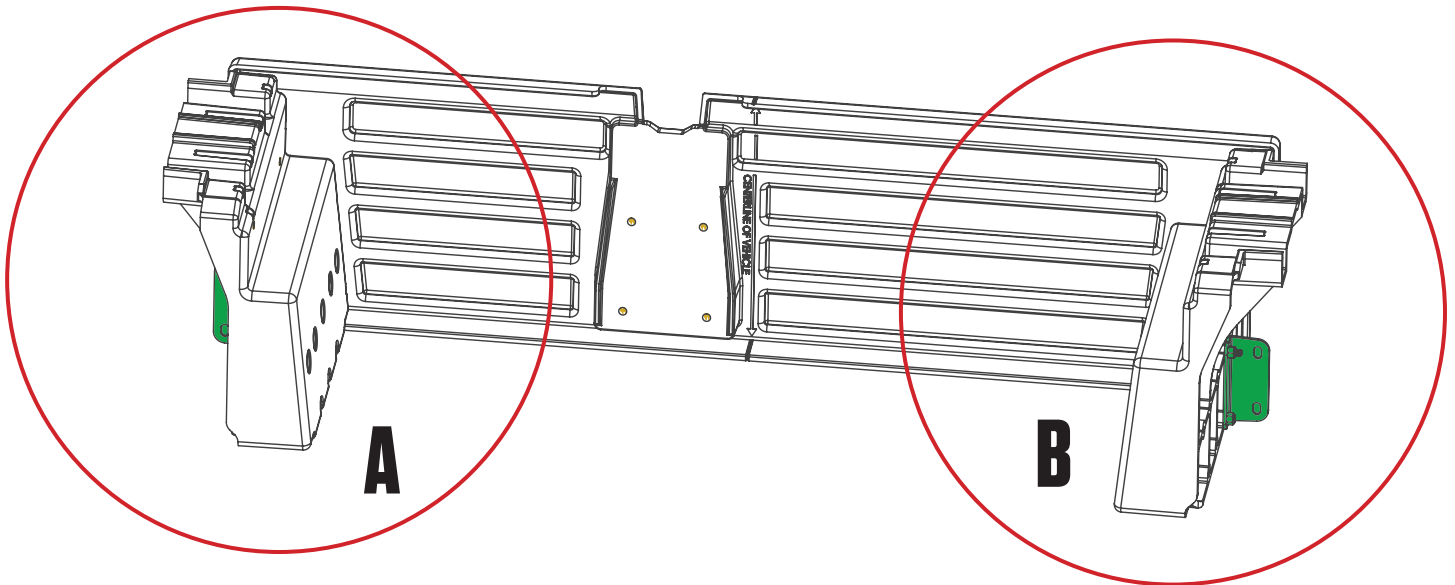

DETAIL A

DETAIL B

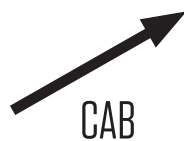
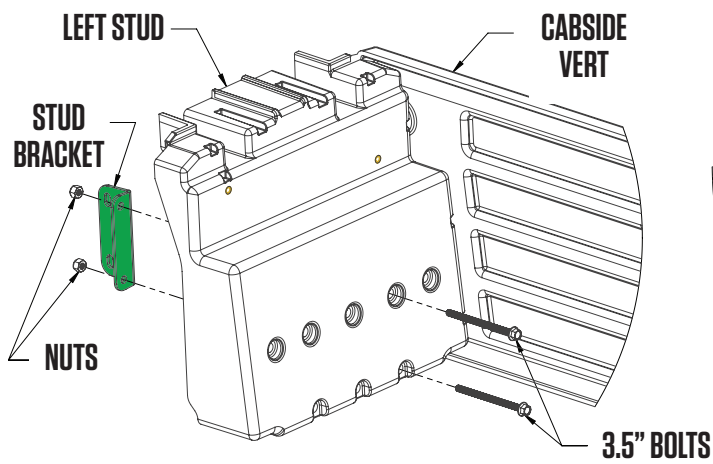

CAB

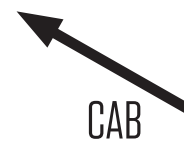
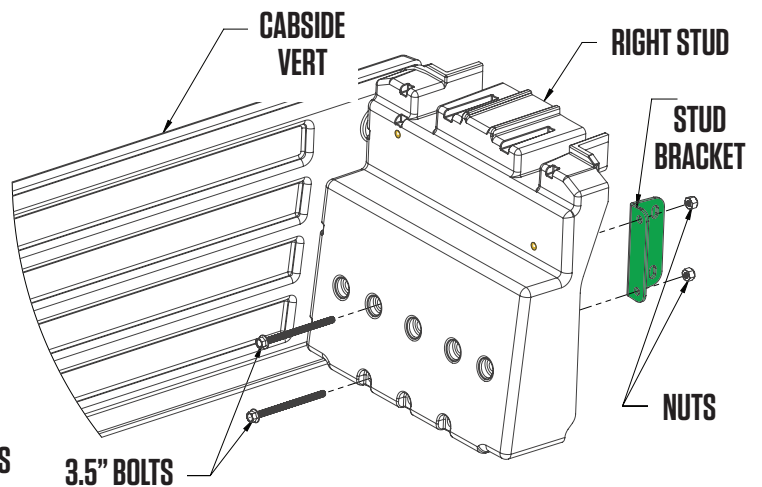

CAB

ASSEMBLY: MOUNT ASSEMBLY

- Install cabside vert/stud assembly in pickup bed and position against cabside panel of bed.
- Align molded-in centerline markings on cabside vert with the centerline marks on the pickup bed.
- The stud bracket must be located on the tailgate side of the cabside bracket.

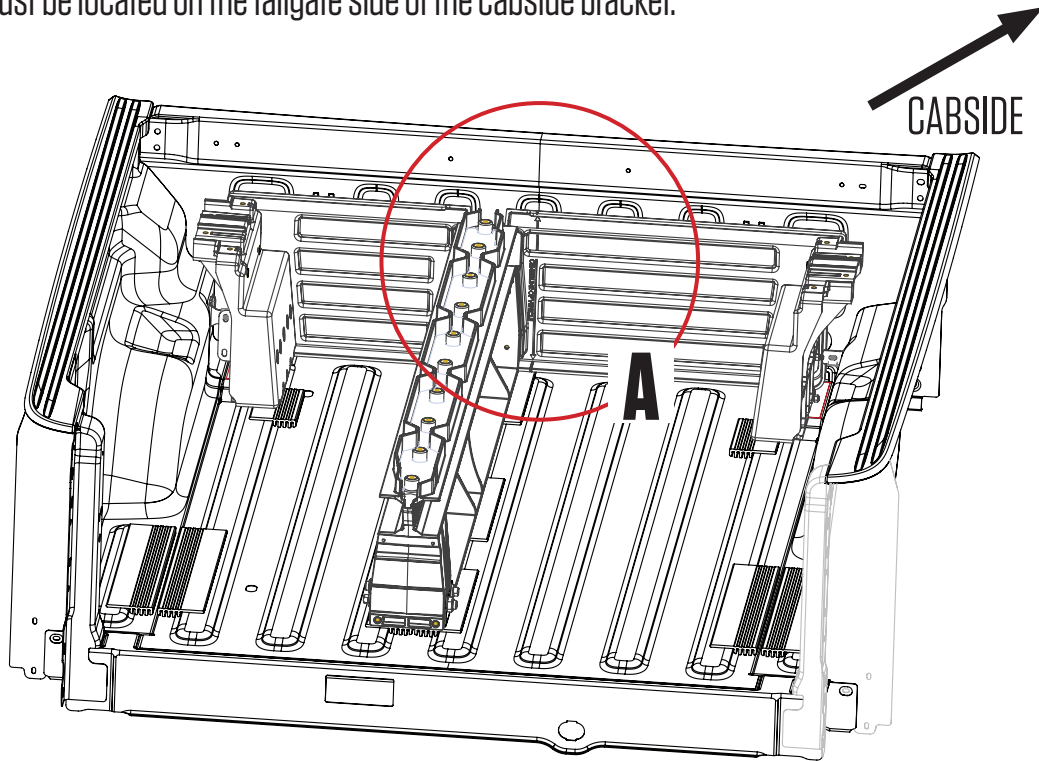

DETAIL A

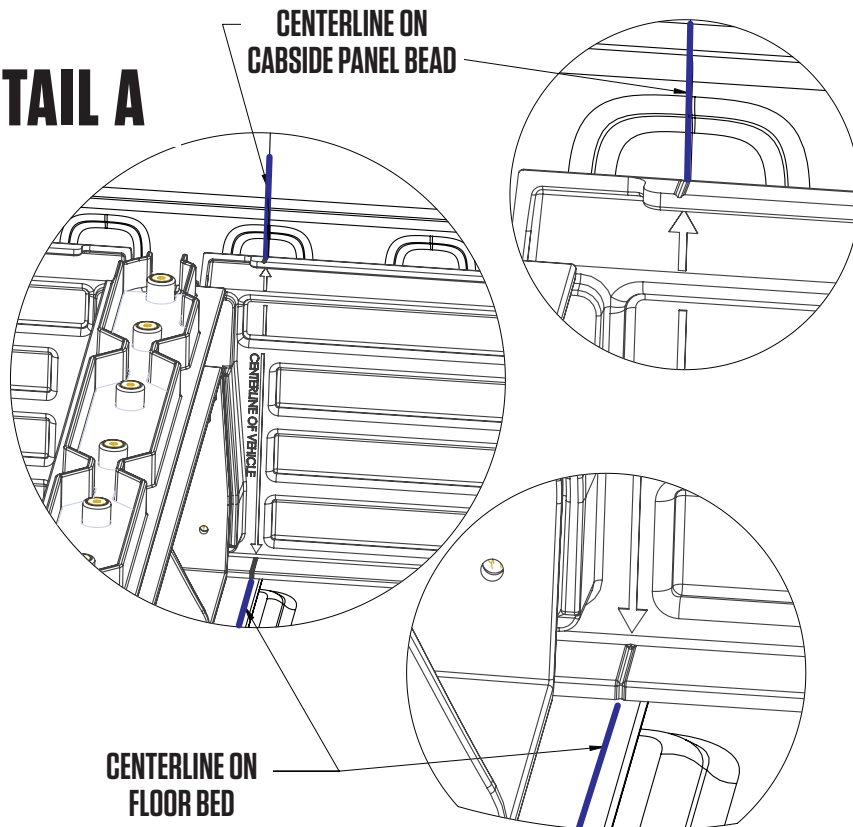

ASSEMBLY: MOUNT ASSEMBLY

- Referencing **DETAIL A**, using a 10" socket extension, loosely assembly .905" bolt through top slot in stud bracket into U-nut in cabside bracket; **BAG S1**. Tighten bolt securely.
- Repeat on right side.

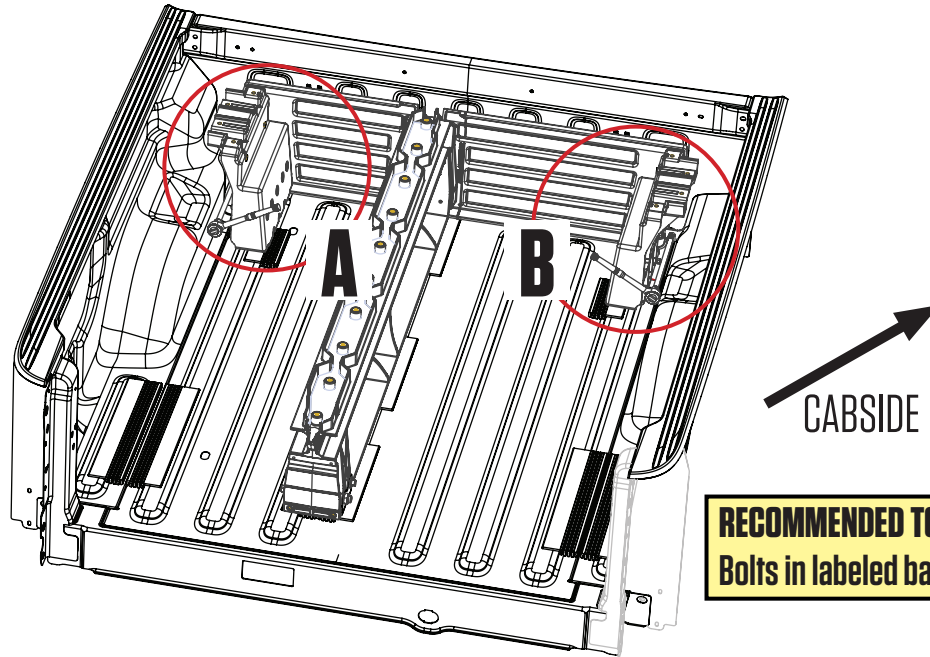

DETAIL A

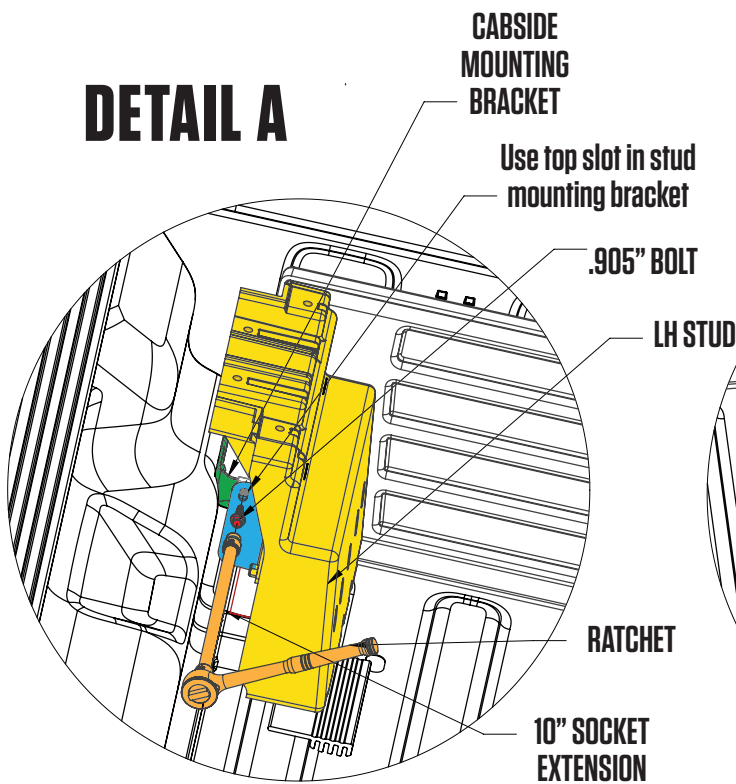

CABSIDE MOUNTING BRACKET

DETAIL B

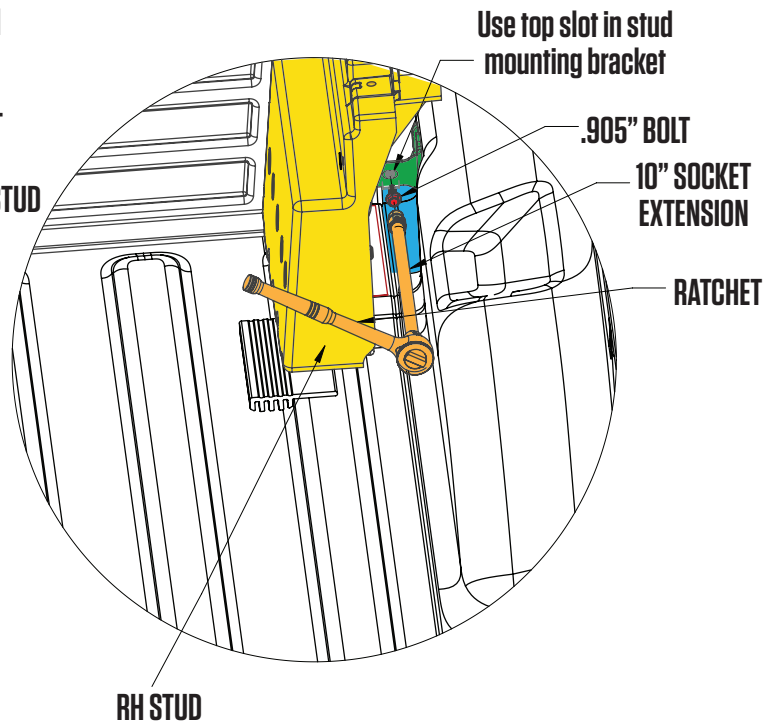

INSTALL: C-CHANNELS

IMPORTANT: There is a left and right ammo can. The inside of each ammo can is marked L or R.

- Loosely place driver side ammo can at tailgate corner of bed. The axle will be closest to you.
- Place driver side C-channel on ledge of stud and ammo can with end plate on the stud (cabside).
- **DETAIL A:** Place nylon washer on eight .905" bolts. Insert two bolts through C-channel into ammo can and loosely fasten with flanged nuts. Make sure the bolt head is on the C-channel side, not inside the ammo can; **BAG S1, BAG WASHERS, BAG N1. KEEP LOOSE.**
- **DETAIL B:** Attach C-channel to stud with same bolts; **BAG S1.**
- Repeat passenger side.

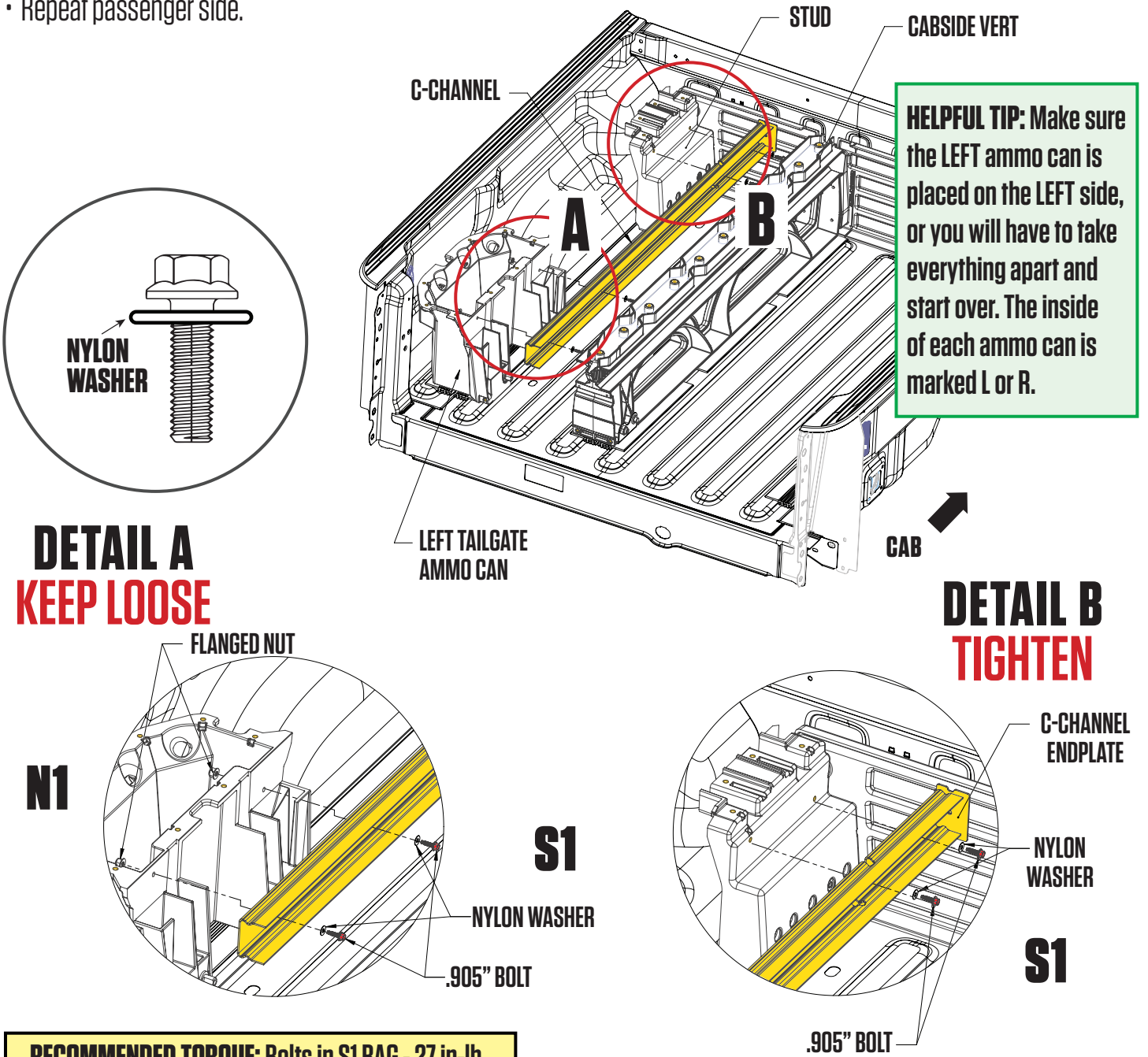

HELPFUL TIP: Make sure the LEFT ammo can is placed on the LEFT side, or you will have to take everything apart and start over. The inside of each ammo can is marked L or R.

DETAIL A
KEEP LOOSE

DETAIL B
TIGHTEN

RECOMMENDED TORQUE: Bolts in S1 BAG - 27 in.-lb.

INSTALL: DECK HALVES

- Loosely place deck panel on side stud, center vert and ammo can.
- Shift ammo can forward, rearward, L-R, as necessary to align with fully seated deck panel.
- Loosely assemble:
 - Five bolts through deck panel into center vert; **BAG S1**.
 - Four bolts with nylon and rubber washers installed as shown through deck panel into stud; **BAG S1, BAG WASHERS**.
 - Eight bolts with nylon and rubber washers installed as shown through deck panel into ammo can; **BAG S1, BAG WASHERS**.
 - Tighten all **S1** bolts.
 - **Securely tighten C-Channel/ammo can nuts and bolts.**
- Repeat other side (**making sure you don't forget to securely tighten C-channel/ammo can nuts and bolts**).

S1

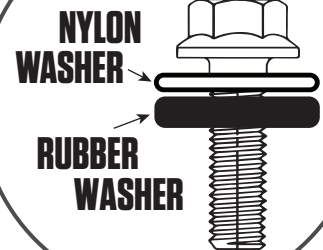
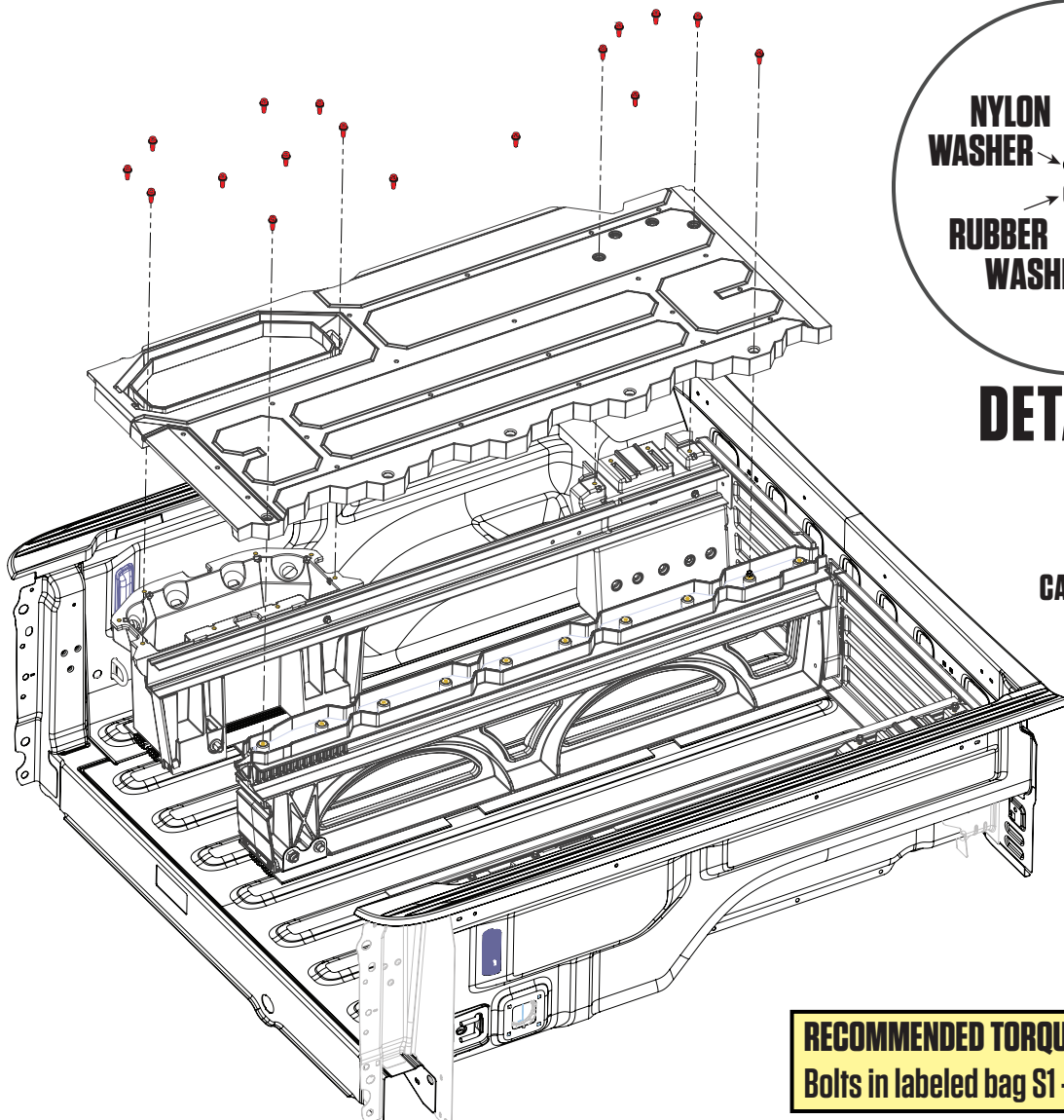

DETAIL A

CAB →

RECOMMENDED TORQUE:
Bolts in labeled bag S1 - 27 in-lb.

DRAWERS: BRACKETS + WHEELS

(SO EASY A CHIMPANZEE CAN DO IT)

- Each drawer has a left and a right bracket. Bolt the brackets into place via bottom two holes in bracket with 3/4" length bolts. Use the 2" length bolt for the upper cabside wall hole in bracket; **BAG DRAWER 1**.
- Install a tube brace in each drawer with two 3/4" length bolts; **BAG DRAWER 1**, **BAG DRAWER 2**.
- Attach wheels onto the drawer brackets with a 7/32" hex wrench; **BAG WHEELS**.

RECOMMENDED TORQUE:

Bolts in labeled bags **DRAWER 1** and **DRAWER 2** - 27 in-lb.

Bolts in labeled bag **WHEELS** - 90 in-lb.

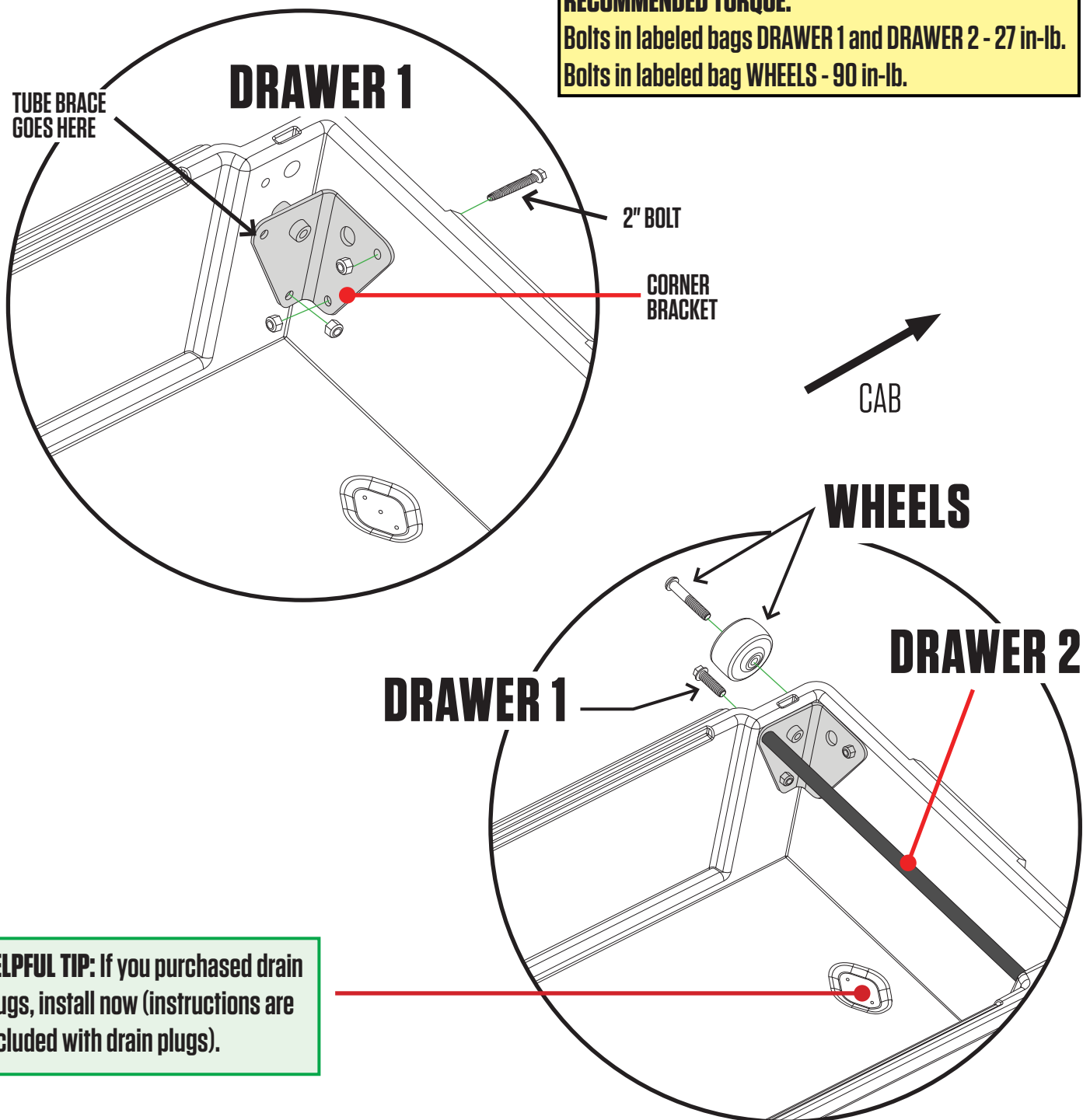

DRAWERS: AXLE WHEELS + WEATHERSTRIPS

- Slide narrow drawer into the left side drawer cavity. **NOTE: It is easier to fully install narrow drawer first.**
- **DETAIL A:** Install two tailgate wheels onto narrow drawer axles with a 7/32" hex wrench; **BAG WHEELS.**
- Repeat with wide drawer.
- **DETAIL B:** Install weatherstrips on top of drawer edges **WITH WIPER BLADE POINTING TOWARD DRIVER.**
IMPORTANT: Incorrect installation of the weatherstrip will funnel water into the drawer: BAD!

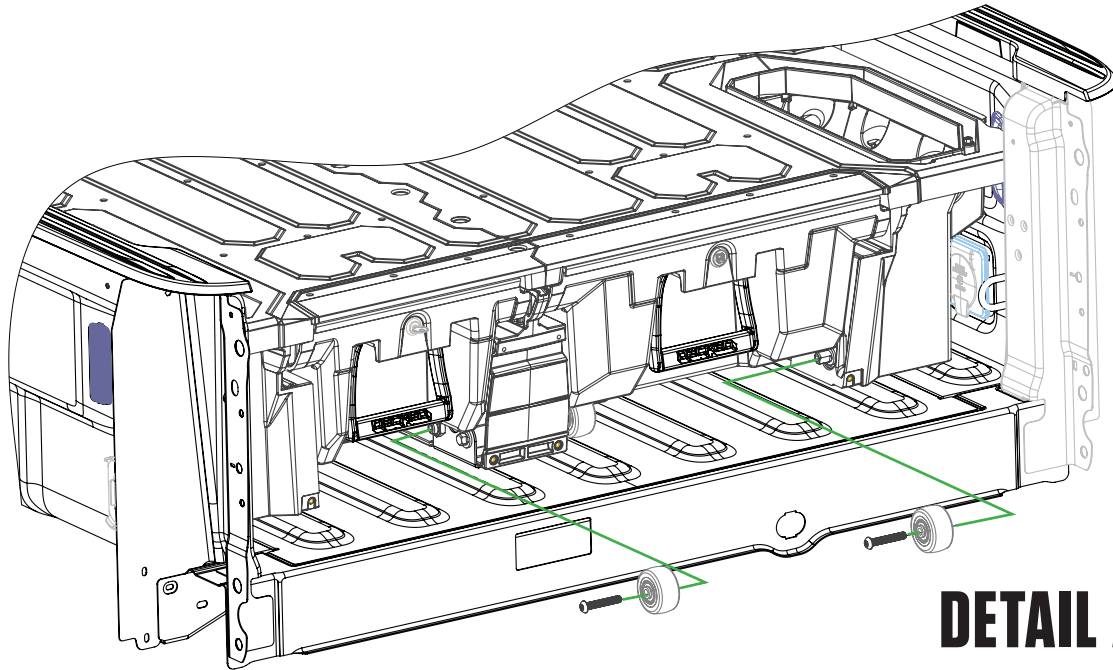

DETAIL A

RECOMMENDED TORQUE:
Wheel bolts - 90 in-lb.

HELPFUL TIP: To make this step easier, support the drawer on a piece of material (approx 2") or have an assistant hold the drawer up against the deck.

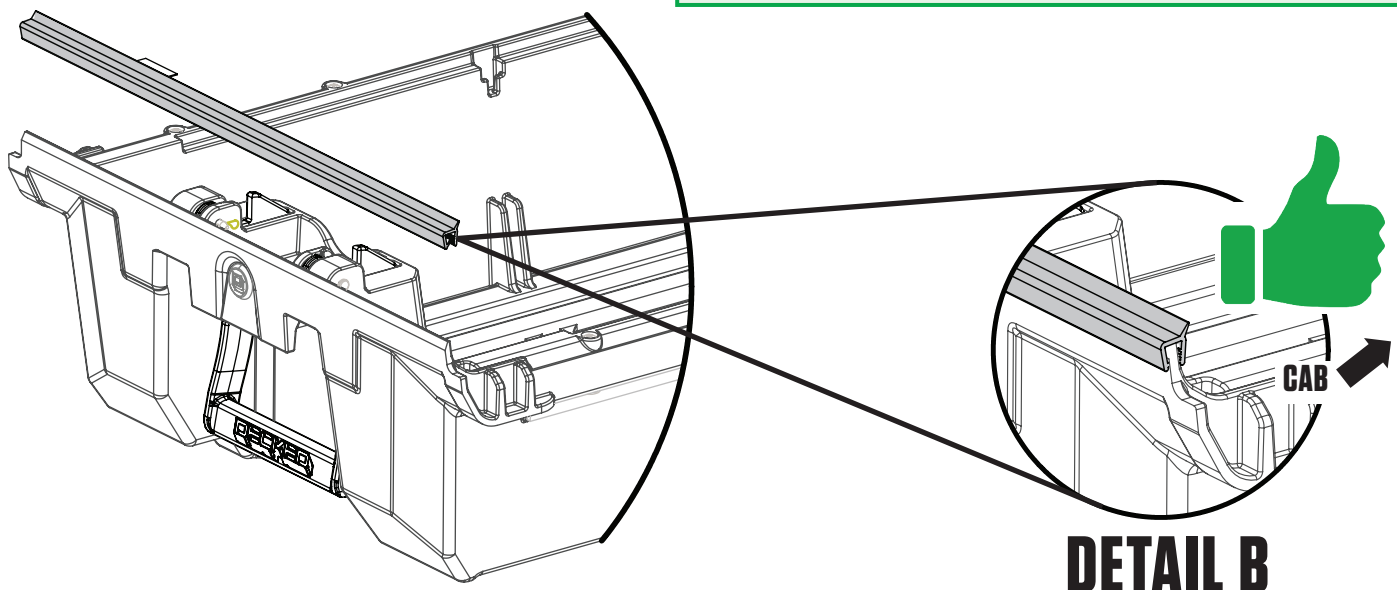

DETAIL B

THE FUN STUFF: TORSION BRACE + BOTTLE OPENER

- Slide torsion brace under center support and tailgate ammo cans.
- Loosely install:
 - Two .905" bolts with nylon washers through the end holes in torsion brace into ammo cans; **BAG PREP MJ1**.
 - Two .905" bolts with nylon washers through the bottom bottle opener holes and torsion brace into center vert; **BAG PREP MJ1, WASHERS**.
 - Two 1/2" length bolts through upper holes in bottle opener into center vert; **BAG FINAL MID, WASHERS**.

NOTE: You will have extra washers.

- Align bottle opener to edges of center vert and tighten four bottle opener bolts.
- Tighten end bolts into tailgate ammo cans.



RECOMMENDED TORQUE:

.905" Bolts - 27 in-lb.

1/2" Bolts - 18 in-lb.

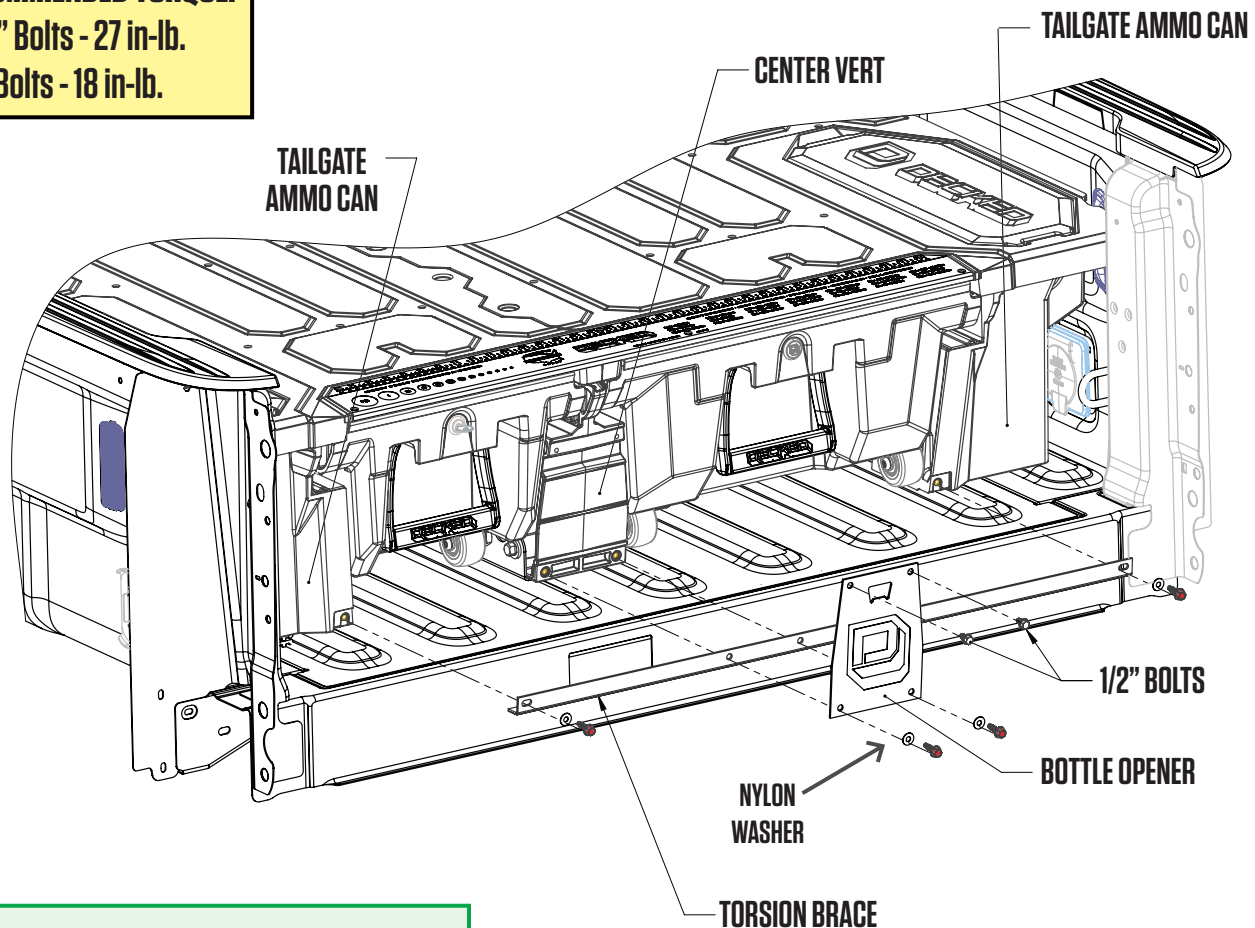

HELPFUL TIP: Bottle opener goes on the outside of torsion brace.

INSTALL: J-HOOKS

- Install J-hook onto tie down bracket and through hole closest to the tailgate in ammo can; **BAG J7C**.
- Install winged-spherical nut-washer, round side down, onto J-hook and partially tighten using your fingers only.
IMPORTANT: Keep J-hook assembly loose.
- Repeat other side.
- Tighten the J-hooks, but **DO NOT OVERTIGHTEN!** Make sure the gap between the side wall of the bed and the deck is equal on both sides.
- Install bolt thread protectors on J-hook ends; **BAG FINAL MID.**

LEFT AMMO CAN

RIGHT AMMO CAN

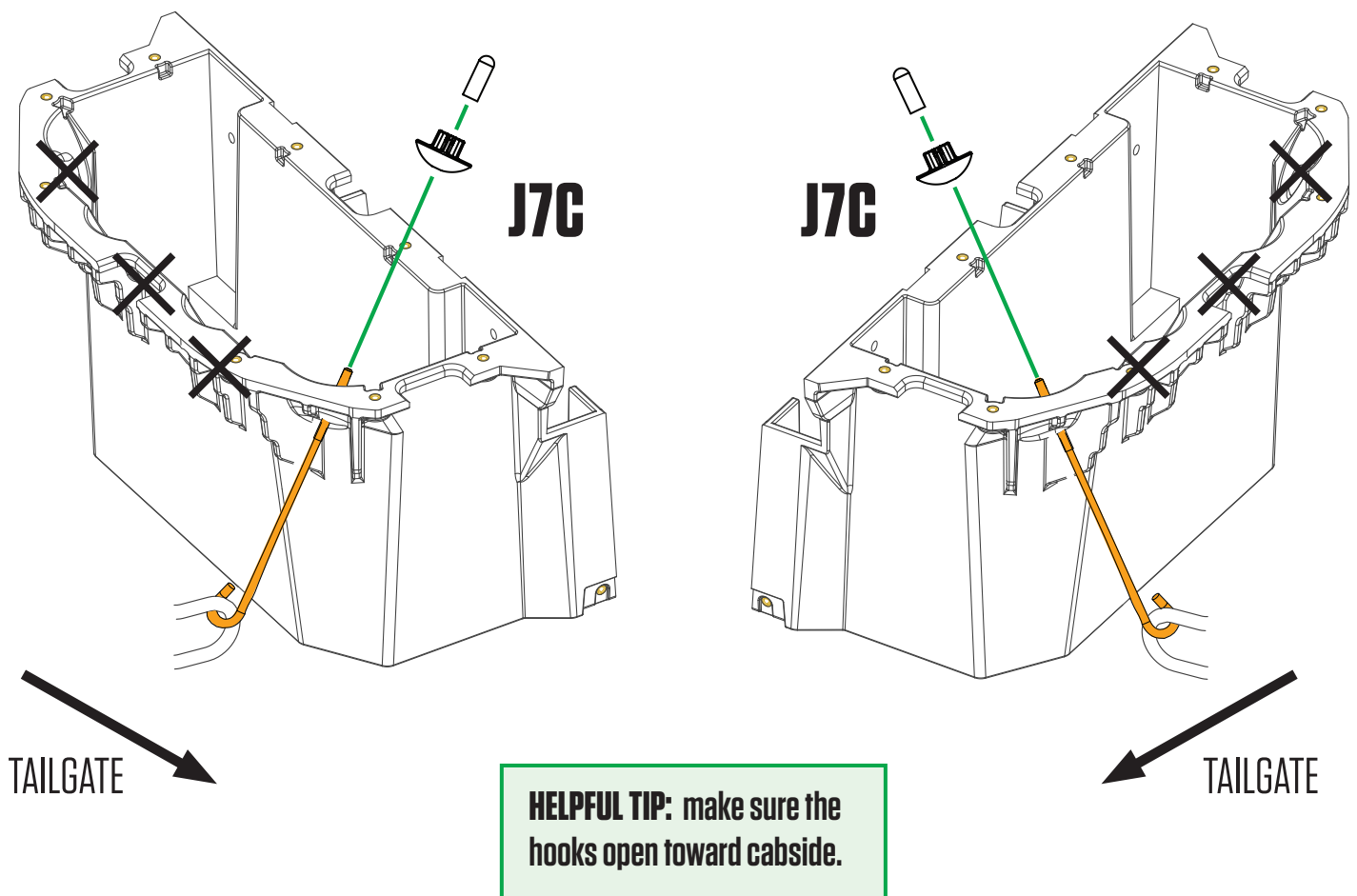

IMPORTANT: You're almost there, so get your favorite beverage ready to crack open in the bottle opener and make a toast to your truck. When finished, immediately post a photo of your significant other, child or canine (in no order of significance - please someone show us your pet alligator) appreciating your accomplishment. Add hashtag #DECKEDUSA | @DECKEDUSA.

FINAL STEPS: THE RULER

- Install ruler with six 1/8" hex screws; **BAG FINAL MID**. Start screws with fingers to avoid cross-threading. Tighten just until snug. Overtightening will strip the inserts.

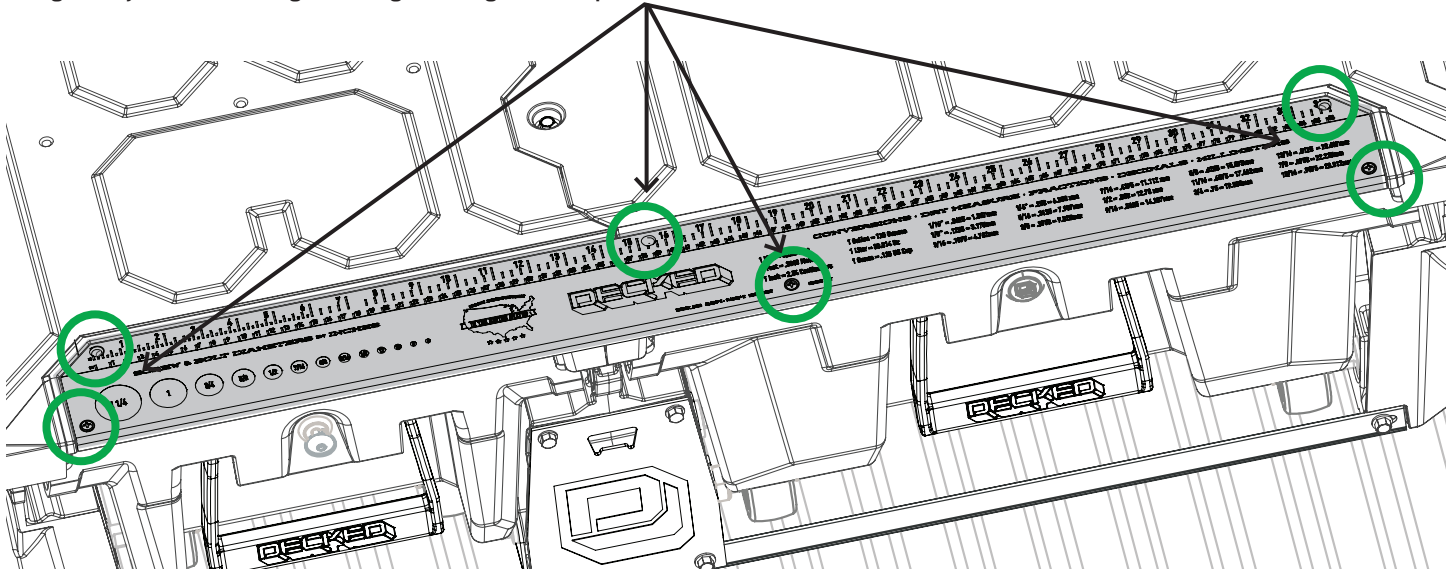

FINAL STEPS: AMMO CAN LIDS

- **DETAIL A:** Ammo can lids are left (marked L) and right (marked R) side specific.
- **DETAIL B:** Holding lid in orientation shown, insert tab on tailgate end of ammo can lid and push the cabside end of lid down to secure. Don't be afraid to push down hard.
- Insert lock hole plugs, unless you are fitting the optional drawer locks, in which case install drawer locks now (instructions with locks); **BAG FINAL MID**.

DETAIL A

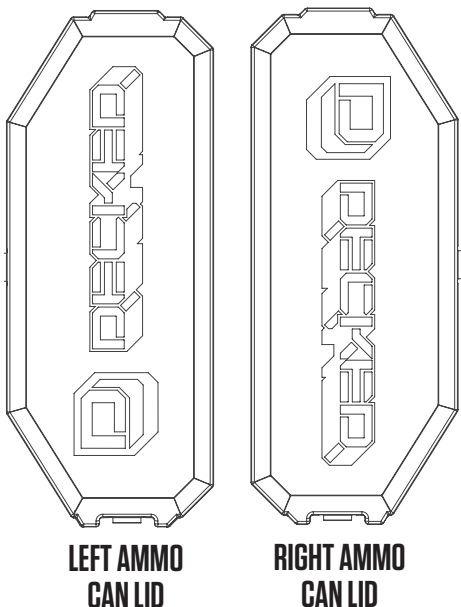

LEFT AMMO
CAN LID

RIGHT AMMO
CAN LID

DETAIL B

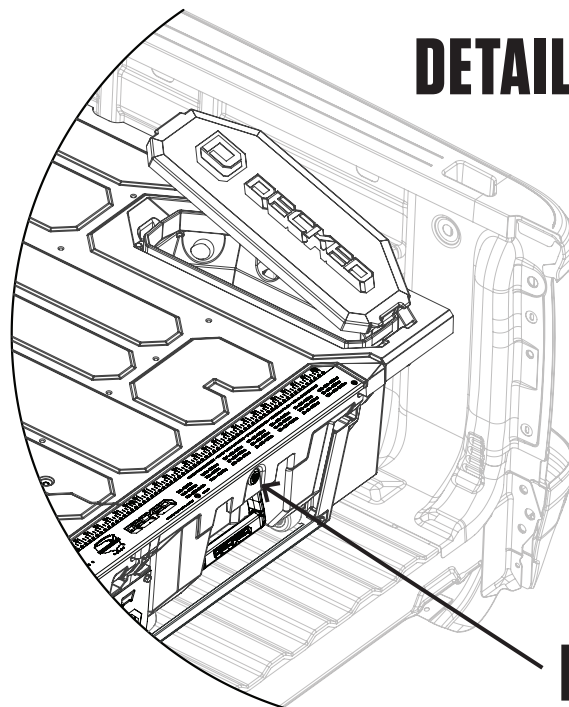

FINAL MID

DECKED 3-YEAR LIMITED WARRANTY

And now....a word from our lawyers.

DECKED LLC warrants to the original purchaser of this product that the product will be free from manufacturing defects in workmanship and materials for a period of three (3) years from the date of the original purchase. If within three (3) years from the original date of purchase this product fails due to defect in materials or workmanship, DECKED LLC will replace any defective part at its option.

The original purchaser must contact the DECKED LLC customer service team and provide a description of the defective part, including digital pictures if requested, with the original purchase documentation as validation of warranty coverage or have previously activated their warranty online.

This warranty DOES NOT cover or apply to:

- Damage to the product due to misuse, mishandling and abuse.
- Products not used in accordance with the manufacturer's instructions or recommendations.
- Product not assembled or installed according to manufacturer's instructions.
- Normal wear and tear.
- Undeclared damage to the system during shipping, acts of God. In addition, consequential damage and incidental damages (including lost time) such as damage to persons or property are not covered under this warranty.

REGISTER YOUR PRODUCT FOR ANY FUTURE WARRANTY NEEDS. [DECKED.COM/REGISTER](https://www.decked.com/register)

#DECKEDUSA | @DECKEDUSA