

**FRONT SIDE TUBE TO FRONT CROSS BAR  
MOUNTING KIT PAGES 7 & 8**

2 - 3/8 X 1 1/2 CARRIAGE BOLTS  
2 - 3/8 HD. FLATWASHERS ( 1 3/8" DIA.)  
2 - 3/8 THIN NYLON LOCK NUTS

**RAINGUTTER CLAMP ASSEMBLY LOWER  
SECTION PAGE 7**

2 - LOWER RAINGUTTER MOUNTS W/PADS  
2 - RAINGUTTER BOTTOM CLIPS  
4 - 3/8" BLACK PLASTIC SPACERS  
4 - 5/16 X 1 1/4" CARRIAGE BOLTS  
6 - 5/16 FLATWASHERS  
6 - 5/16 NYLON LOCKNUTS  
2 - BLACK VINYL COVERS

**RAINGUTTER CLAMP ASSEMBLY TOP  
SECTION SUPPORT PLATE PAGE 7**

2 - TOP SUPPORT PLATES ( THREADED )  
2 - 1 1/2 DIA. RUBBER BUMP STOPS  
2 - 3M SCUFF PADS  
4 - 5/16 X 1 CARRIAGE BOLTS  
12 - 5/16 FLATWASHERS  
4 - 5/16 NUTS  
2 - 3/8 FENDER WASHERS  
2 - 5/16 LOCKWASHERS  
2 - 5/16 X 1 3/4 ALL THREAD BOLTS  
4 - 5/16 NYLON LOCKNUTS

**CROSSBAR KIT PAGES 7 & 8**

1 - FRONT CROSSBAR ( 55 3/8" )  
2 - TOP CROSSBAR BRACKETS  
2 - 3/8 X 2 CARRIAGE BOLTS  
2 - 3/8 FLATWASHERS  
2 - 3/8 NYLON LOCKNUTS  
4 - BLACK PLASTIC PLUGS

**REAR SUPPORTS RUBBER  
BUMP STOP KITS PAGES 5 & 6**

4 - 1 1/2" DIA. RUBBER BUMP STOPS  
4 - 5/16 X 3 1/2" ALL THREAD BOLTS  
4 - 3/8 FENDER WASHERS ( 1 1/2" DIA.)  
4 - 5/16 LOCKWASHERS  
8 - 5/16 FLATWASHERS  
12 - 5/16 NUTS  
4 - 3M SCUFF PADS  
4 - BLACK TUBING THREAD COVERS  
( CUT TO FIT )  
2 - BLACK HARD PADS ( 1 1/4" X 2 1/2" )  
4 - BLACK VINYL COVERS

**TOP SUPPORT BARS & CROSSBAR KIT PAGE 8**

2 - TOP SUPPORT BARS ( RT. & LT.)  
1 - TOP SUPPORT CROSSBAR ( 40 3/8 " )  
4 - 3/8 X 1 1/4 CARRIAGE BOLTS  
4 - 3/8 USS FLATWASHERS  
4 - 3/8 NYLON LOCKNUTS

**LOWER SUPPORT KIT PAGE 4**

2 - LOWER SUPPORTS  
2 - 1/2 X 1 1/2 BOLTS  
2 - 1/2 LOCKWASHERS  
2 - 1/2 LARGE FLATWASHERS

**INNER SUPPORT KIT PAGE 4**

2 - INNER SUPPORTS  
4 - 3/8 NUTS  
4 - 3/8 LOCKWASHERS  
4 - 3/8 USS FLATWASHERS ( 1" DIA.)

**TOP ANGLE MOUNTING BRACKET KIT PAGE 5**

2 - TOP ANGLE MOUNTS  
2 - 7/16 X 1 1/2 BOLTS  
4 - 7/16 SAE FLATWASHERS (15/16" DIA.)  
2 - 7/16 TAP LOCKNUTS

**REAR SUPPORT KIT PAGE 5**

2 - REAR SUPPORTS (RT & LT)  
4 - 7/16 X 1 1/2 BOLTS  
2 - BLACK 1/8" THICK NYLON PADS  
8 - 7/16 SAE FLATWASHERS (15/16" DIA.)  
4 - 7/16 TAP LOCKNUTS

**FRONT AND REAR CONNECTING TUBE KIT PAGES 5 & 8**

1 - FRONT CONNECTING TUBE ( 28 7/8 " )  
1 - REAR CONNECTING TUBE ( 38 " )  
4 - 5/16 X 1 BUTTON HEAD ALLEN BOLTS  
4 - 5/16 LOCKWASHERS  
4 - 5/16 EXTRA THICK FLATWASHERS  
1 - 3/16 ALLEN WRENCH

**Part# 20099**  
*JL Hardtop, 4D Adventure Half Rack*

**Installation Instructions**

**Please Note! For an easier installation, leave all fasteners loose until directed to tighten.**

**Rear Mounting Instructions**

1. Remove factory rear bumper as shown on page 3.
2. Install inner support brackets as shown on bottom of page 3, and figures A & B on page 4.
3. Install rear mounting brackets, page 4, figures B & C. Adjust brackets so the Velcro pad is as close to the body as possible. Align and tighten all fasteners.
4. Re-install rear bumper, support brackets, and plug in the wiring. Tighten all fasteners.
5. Re-install rear plastic panels (6-8mm head screws)
6. Install top angle brackets to rear mounts as shown on page 5, slightly tighten to hold in place.
7. Assemble rear bump stops. Follow the instructions on page 6.
8. Install rear supports and black nylon pads to top angle bracket, as shown on page 5. Slightly tighten to hold in place.

**Front Clamp Assembly**

1. Assemble rain gutter mounts as shown on page 7, lines 1,2 and 3.
2. Install mounts on factory rain gutter as shown on page 7, figure A.
3. Install support crossbar to mounting clamps as shown on page 7, line 4.

**Top Crossbars and Side Bars**

1. Install the top side bar tubes to rear mounting supports. Install front connecting tube to the side bar tubes, refer to page 8.
2. Center side bar tubes on front crossbar and secure to crossbar, as shown on pages 7 and 8.
3. Align Adventure Rack and tighten all fasteners.
4. After completing step 3, refer to pages 5 and 6 for placement of 3M pads and rubber bump stop adjustment.

**Weather Proofing Connecting Joints:**

1. Back out the 5/16 button head bolts approximately ¼" from the tubes. Apply black silicon to the threads and hole. Re-tighten bolt.
2. Apply black silicon around the area where the front and rear tubes slide over the supports.
3. Touch up all nicks and scratches, that normally occur with a roof rack, with some black enamel paint.
4. We recommend touching up all mounting hardware with black enamel paint. During installation the coating on the hardware can get stripped off.

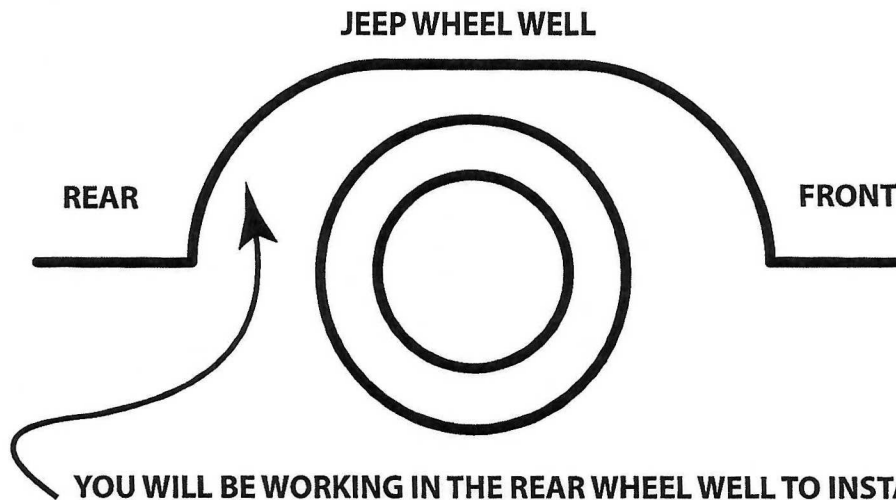

YOU WILL BE WORKING IN THE REAR WHEEL WELL TO INSTALL THE REAR LOWER MOUNTING BRACKETS FOR THE ROOF RACK

- 1 - REMOVE THE PLASTIC PANEL BEHIND THE REAR TIRES ( 6 - 8MM HEAD SCREWS )
- 2 - REMOVE THE OUTBOARD BUMPER SUPPORT BRACKETS ( 8 - BOLTS 16MM HEAD )
- 3 - PULL WHITE TAB UP ABOUT 1/8" ON THE SENSOR WIRING CONNECTER AND UN-PLUG CONNECTER, FIGURE C , ALSO DISCONNECT FROM METAL BRACKET
- 4 - REMOVE THE 4 - 16MM NUTS ( FIGURE A ) AND BOLTS ( FIGURE B )
- 5 - TILT BUMPER UP AND REMOVE REAR BUMPER.

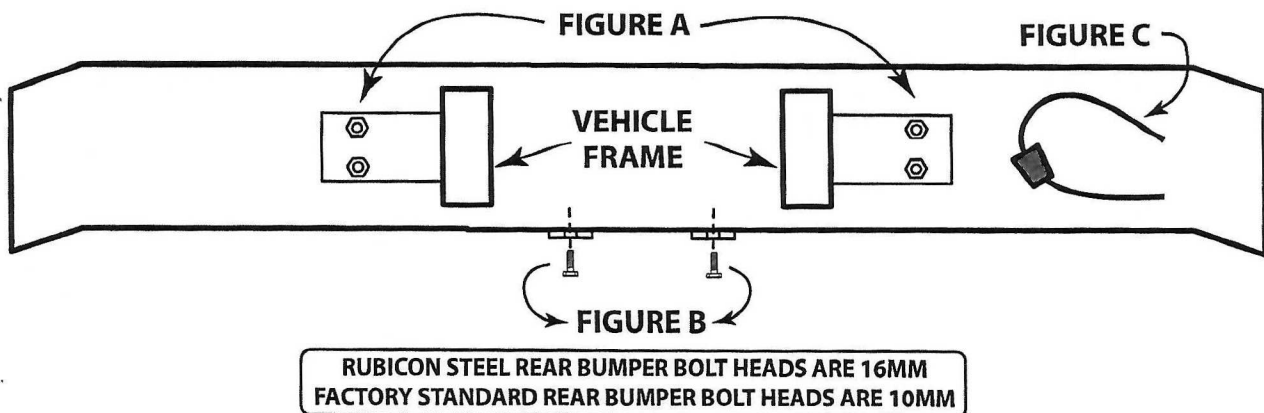

- 6 - AFTER YOU HAVE REMOVED ALL THE PANELS AND BUMPER , YOU WILL SEE A LARGE OVAL HOLE IN THE BODY STRUCTURE AND ON THE BOTTOM YOU WILL SEE A SQUARE HOLE.
- 7 - INSTALL THE INNER SUPPORT BRACKET THRU THE OVAL HOLE AS SHOWN IN FIGURE A, PAGE 4.

**FIGURE A**

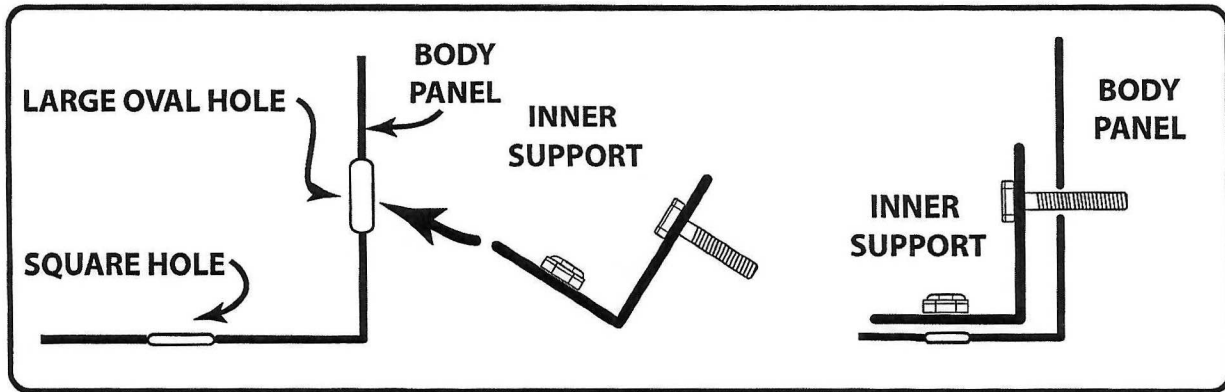

**FIGURE B**

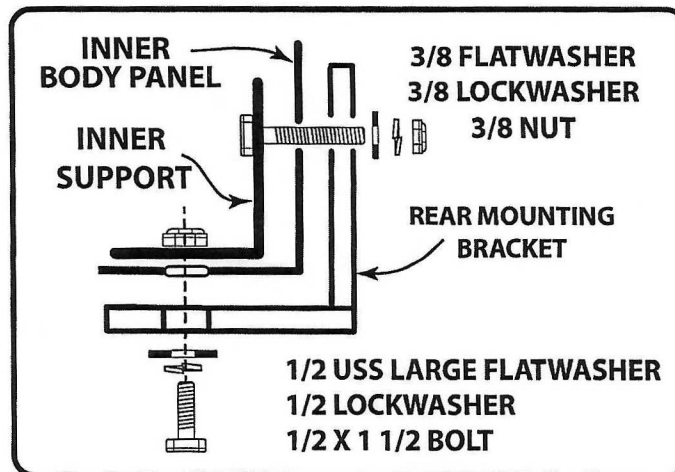

**FIGURE C**

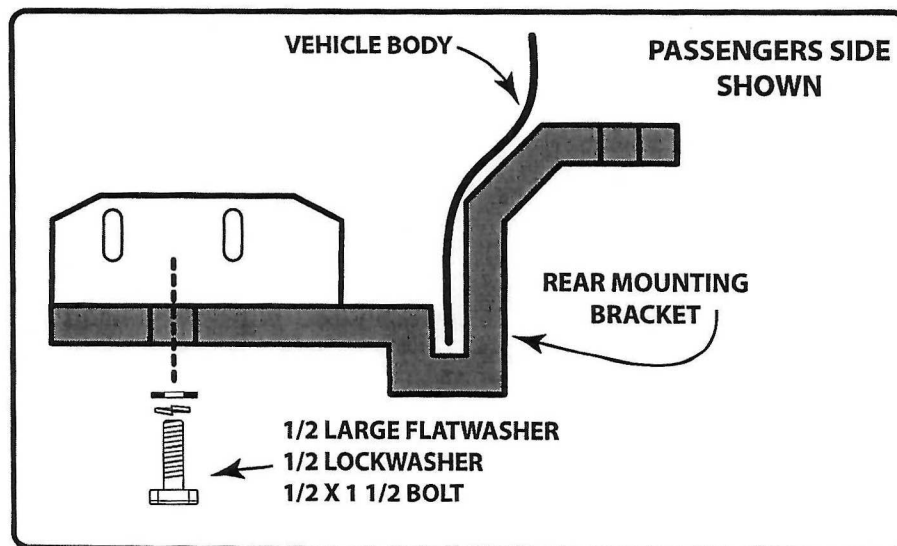

**FIGURE C**  
THIS VIEW IS FROM  
UNDER THE JEEP  
LOOKING TOWARD  
THE REAR OF THE  
VEHICLE, ON THE  
PASSENGERS SIDE

**PART # 20099**

**REAR TOP SUPPORT BRACKET AND REAR CONNECTING TUBE  
INSTALLATION DRAWING**

( PASSENGERS SIDE SHOWN )

REAR CONNECTING TUBE 38" LONG

REAR SUPPORT

LOOKING FORWARD FROM  
THE REAR OF THE VEHICLE  
THIS IS THE PASSENGERS  
SIDE VIEW

BLACK SILICONE AROUND  
THE CONNECTIONS

UPPER BUMP  
STOP BRACKET

BUMP STOP  
BRACKETS FACE TO  
THE FRONT OF THE  
WRANGLER

5/16 X 1 BUTTON HEAD ALLEN BOLT  
5/16 EXTRA THICK FLATWASHER  
5/16 LOCKWASHER  
( USE 3/16 ALLEN WRENCH PROVIDED )

3M PAD USED ON  
TOP BUMP STOP

3M PAD AND HARD  
BLACK PAD USED  
ON LOWER BUMP STOP

BLACK VINYL COVERS

BLACK HARD  
PAD

LOWER BUMP  
STOP BRACKET

REAR SUPPORT

UPPER BUMP STOP  
BRACKET  
( HARD TOPS ONLY )

BUMP STOP ASSEMBLY

BUMP STOP MOUNTING BRACKET

LOWER BUMP STOP  
MOUNTING BRACKET

THE TWO TOP HOLES  
ARE FOR OPTIONAL  
LADDER MOUNTING

7/16 TAP LOCKNUT  
7/16 SAE FLATWASHER

7/16 X 1 1/2 BOLT  
7/16 SAE FLATWASHER

7/16 X 1 1/2 BOLT  
7/16 SAE FLATWASHER

VEHICLE BODY

BLACK 1/8" THICK  
NYLON PAD

TOP ANGLE MOUNTING  
BRACKET

7/16 TAP LOCKNUT  
7/16 SAE FLATWASHER

REAR MOUNTING  
BRACKET

1/2 LARGE FLATWASHER  
1/2 LOCKWASHER  
1/2 X 1 1/2 BOLT

REAR SUPPORTS UPPER AND  
LOWER BUMP STOPS

FIGURE A

BUMP STOP ASSEMBLY

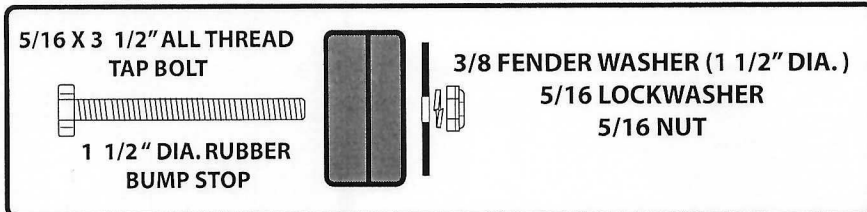

1 - ASSEMBLE RUBBER BUMPER TO TAP BOLT AND TIGHTEN. REFER TO FIGURE A

2 - INSTALL RUBBER BUMP STOPS TO REAR SUPPORTS BEFORE INSTALLING ON VEHICLE. REFER TO PAGE 5 & 6 INSTALL HARDWARE LOOSE TO HOLD ON DURING INSTALLATION.

FIGURE B

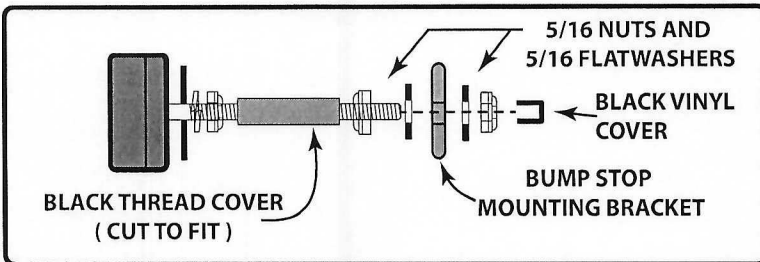

3 - FINISH ROOF RACK INSTALLATION AND AFTER THE ROOF RACK IS ALIGNED AND ALL FASTENERS ARE TIGHTENED, POSITION THE RUBBER BUMP STOP WHERE IT WILL TOUCH THE BODY. AT THAT PLACE, REMOVE THE WHITE BACKING FROM THE 3M SCUFF PAD AND STICK TO BODY.

4 - ADJUST THE RUBBER BUMP STOP SO IT JUST TOUCHES THE BODY. SECURE BY TIGHTENING THE 5/16 NUTS AND LOCKWASHER.

5 - USE SOME VASOLINE JELLY ON THE RUBBER IF A SQUICKING NOISE IS HEARD, AS THE RUBBER BUMPER WILL GET HARD OVER TIME.

FIGURE C

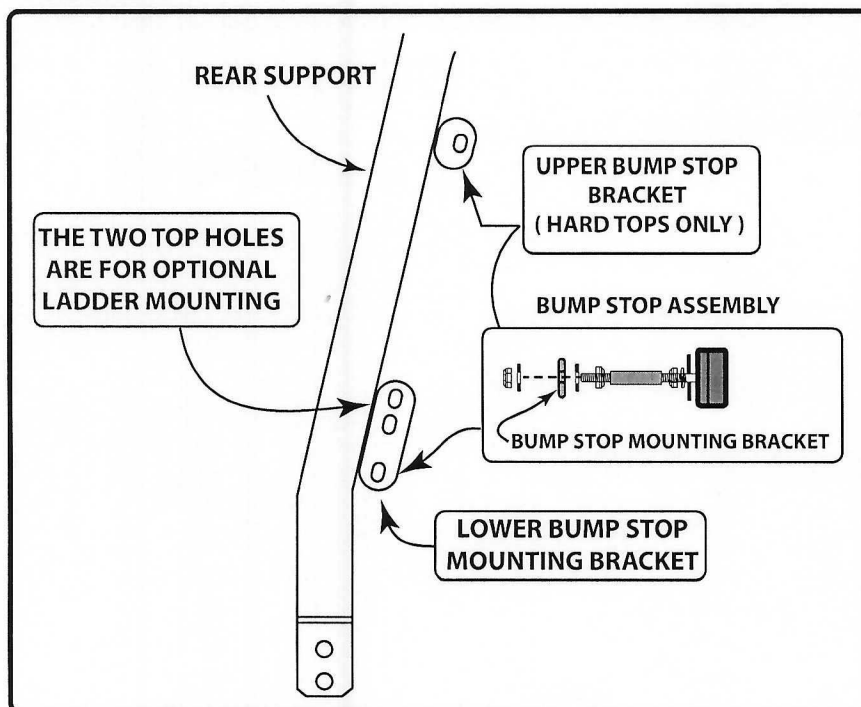

THIS IS LOOKING FROM THE PASSENGERS SIDE TOWARD THE REAR SUPPORT

**FRONT CLAMP ASSEMBLY AND INSTALLATION INSTRUCTIONS**

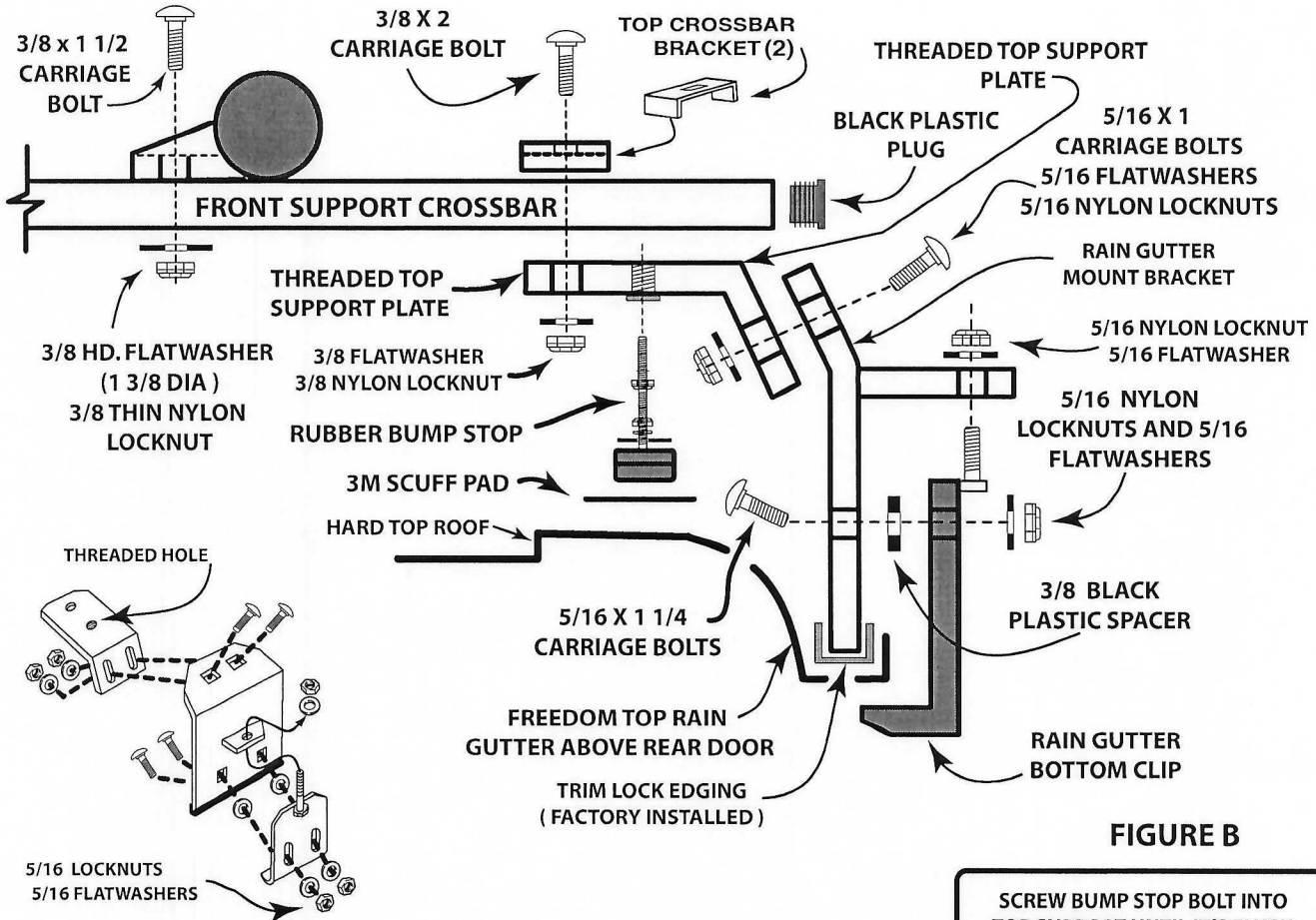

**FIGURE B**

**FIGURE A**

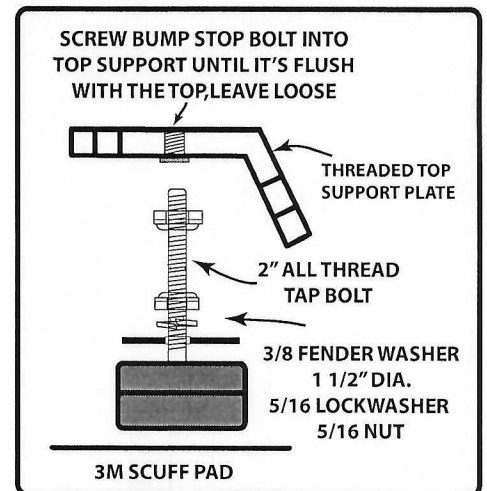
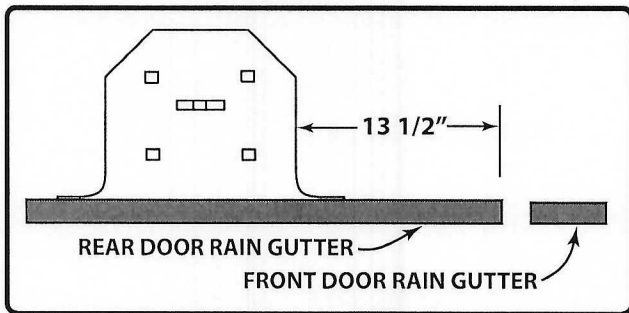

- 1- ASSEMBLE RAIN GUTTER MOUNTING CLAMP AS SHOWN, LEAVE LOOSE. ASSEMBLE TOP BUMP STOP AS SHOWN IN FIGURE B, AND SCREW INTO THREADED PART OF TOP SUPPORT PLATE.
- 2- INSTALL RAIN GUTTER ASSEMBLY IN FACTORY RAIN GUTTER, SPACING AS SHOWN IN FIGURE A, SLIGHTLY TIGHTEN TO HOLD IN PLACE. INSTALL 3M SCUFF PAD WHERE THE BUMP STOP TOUCHES THE ROOF.
- 3 - USING A LEVEL, ADJUST THE BUMP STOP SO THE TOP SUPPORT PLATE IS LEVEL (SIDE TO SIDE) WITH THE VEHICLE.
- 4 - INSTALL THE ROOF RACK SUPPORT CROSSBAR (55 3/8") TO BOTH RAIN GUTTER CLAMPS AND TIGHTEN ALL FASTENERS

**GENERAL DRAWING**  
**PASSENGERS SIDE SHOWN**

