

ALUMINUM XHD & ALL TERRAIN BUMPER SERIES

Components:

1. Over Rider (11541.14/11542.14)
2. Winch Plate (11541.13)
3. Aluminum XHD Bumper (11541.02)
4. Stubby Ends (11541.10/11542.23)
5. All Terrain Bumper (11542.02)
6. Double X Striker (11542.13)

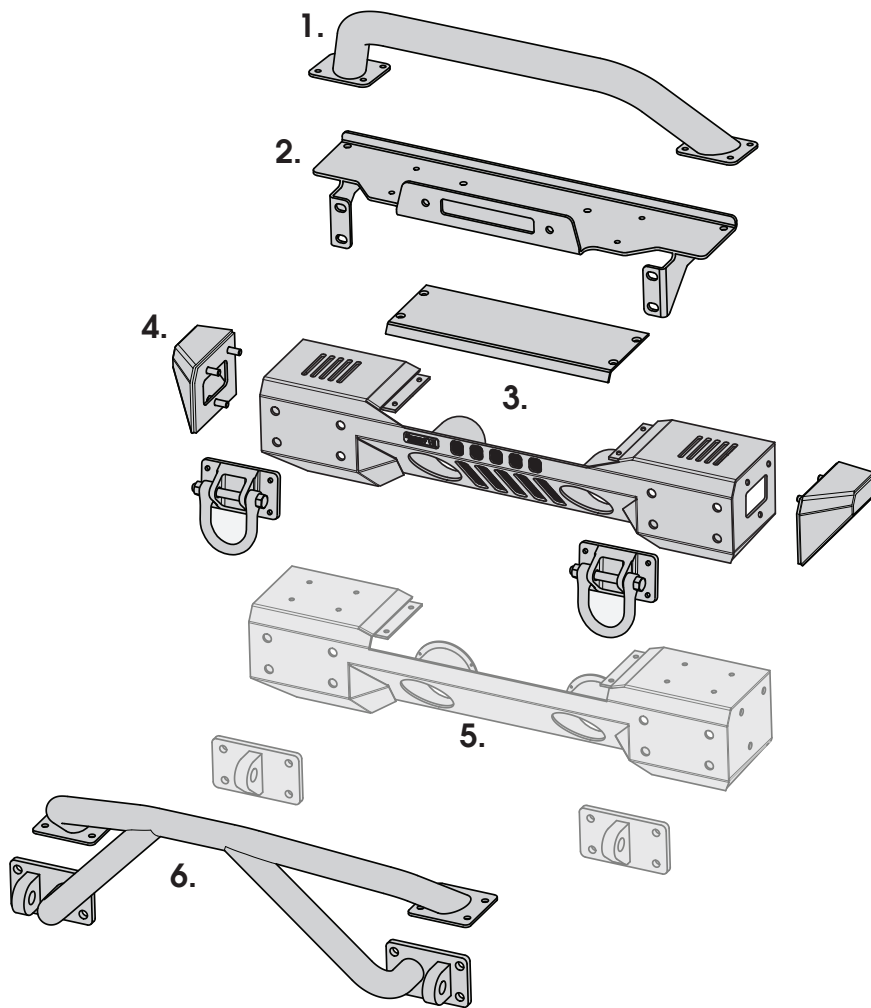

WARNING

To avoid serious injury: never exceed 6.5 ton working load on D-Ring mounts. Use only to assist in vehicle self-recovery; never use D-Ring mounts as a towing point. Inspect before use. Replace if damaged or distorted. Striker bar is not to be used for towing or vehicle recovery.

Read all instructions thoroughly before installation.



ALUMINUM XHD & ALL TERRAIN BUMPER SERIES

3.6L VACUUM PUMP RELOCATION & FRONT BUMPER WINCH PLATE (11541.13)

NOTICE: This section applies only to 2012 and newer JK Wranglers.

Contents:

- | | |
|----------------------|-------------------------|
| 1. Winch Plate | 6. M6 Nylock Nut |
| 2. M6 Bolt Short (1) | 7. Nut plate (2) |
| 3. M6 Bolt Long (1) | 8. M10 Flat Washers (2) |
| 4. L-bracket | 9. M10 Hex Bolts (2) |
| 5. M6 Flat Washer | |

1. Remove the factory bumper. Remove the Factory vacuum pump. Save removed hardware.

2. Remove and flip bushing. Re-attach in flipped position.

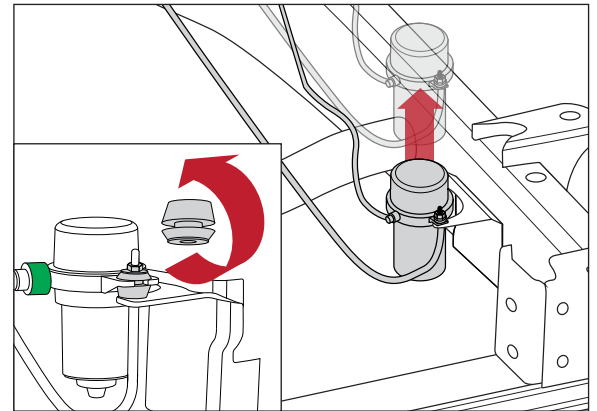

3. Disconnect vacuum pump air-line and wire harness. Do not detach indicated green harness.

4. Rotate vacuum pump.

5. Attach vacuum pump to rear factory stud using hardware removed in step 1. Re-attach air-line and wire harness.

6. Attach L-bracket to vacuum pump.

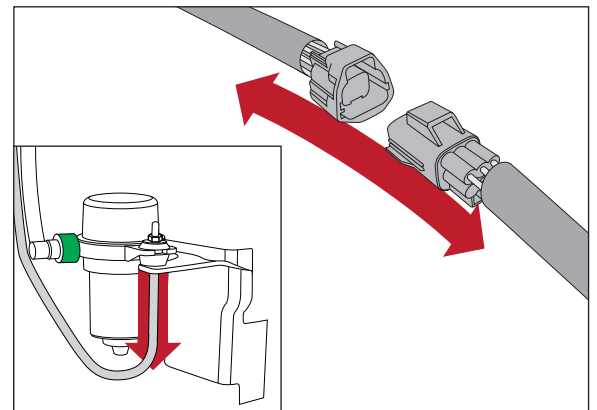



ALUMINUM XHD & ALL TERRAIN BUMPER SERIES

4. Rotate vacuum pump.

5. Attach vacuum pump to rear factory stud using hardware removed in step 1. Re-attach air-line and wire harness.

6. Using M6 Long hardware attach L-bracket to vacuum pump. L-bracket should attach at the bottom of vacuum pump bushing.

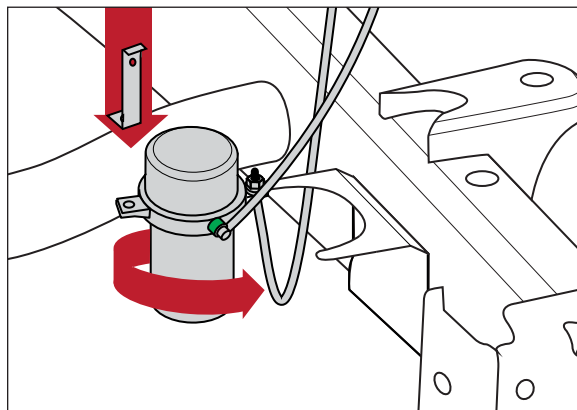

7. Position winch plate on top of the frame horn.

8. Insert nut plate and attach using M10 hardware.

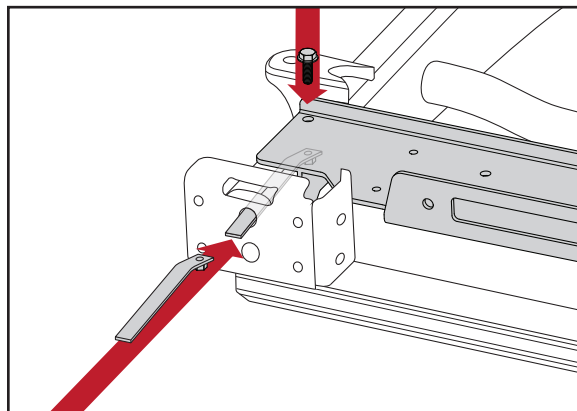

9. Secure L-bracket to winch plate using M6 hardware.

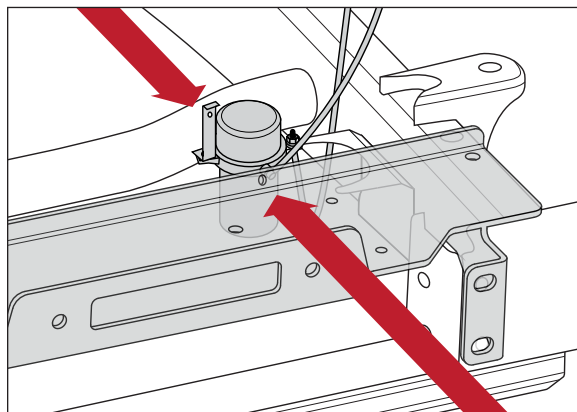



ALUMINUM XHD & ALL TERRAIN BUMPER SERIES

Hoop Over rider (11541.14/11542.14)

NOTICE: Over rider installs easier with bumper detached from vehicle

Contents:

1. Aluminum Hoop Over Rider (1)
2. M6 Hex Bolts (8)
3. M6 Washer (16)
4. M6 Nylock Nuts (8)

1. Remove Aluminum XHD bumper or All Terrain bumper if previously installed. Twist plug at rear of fog light to disconnect wiring. Slide the bumper off frame.

2. Position over rider on top of bumper with hoop leaning forward. Align mounting holes with slotted cutouts on the XHD Aluminum Bumper, or with 4 holes on All Terrain Steel Bumper (remove pre-installed rubber plugs from holes on All Terrain steel bumper). Install using M6 hardware.

3. Follow bumper instructions to reinstall bumper and over rider. Reconnect light harness to fog lights.

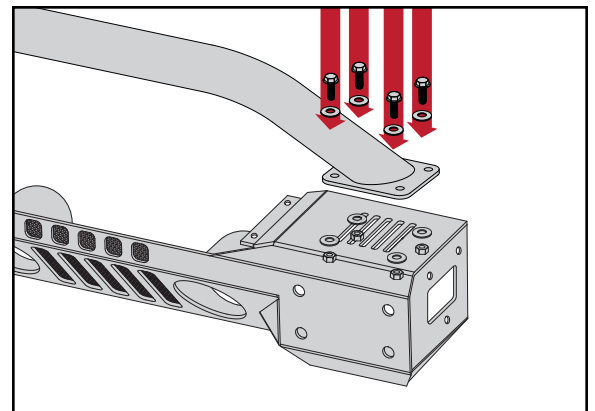



ALUMINUM XHD & ALL TERRAIN BUMPER SERIES

Double X Striker (11542.13)

Contents:

- | | |
|-------------------------|---------------------|
| 1. Double X Striker (1) | 3. M8 Washer (16) |
| 2. M8 Bolt (8) | 4. M8 Lock Nuts (8) |

1. Remove Aluminum XHD bumper or All Terrain bumper if previously installed. Twist plug at rear of fog light to disconnect wiring. Slide the bumper off frame.

2. Position Double X Striker on top of center section. Align mounting holes with slotted cutouts on the XHD Aluminum Bumper, or with 4 holes on All Terrain Steel Bumper (remove pre-installed rubber plugs from holes on All Terrain steel bumper). Install using M6 hardware with the washers on bottom.

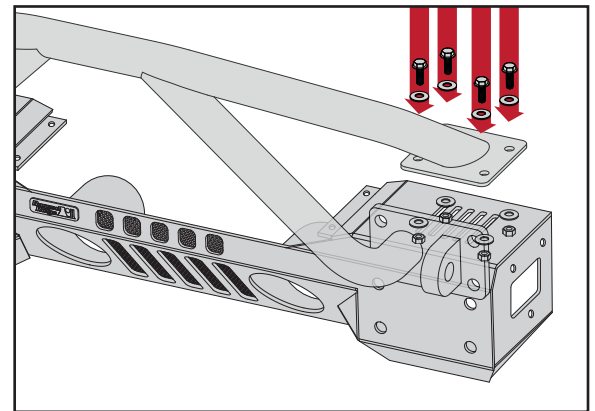

3. Fasten d-ring portion of Double X Striker and center section to frame rails using M12 hardware and nut plates. Tighten evenly. Rubber gaskets included with Aluminum XHD mount between d-ring section of Double X Striker and center section.

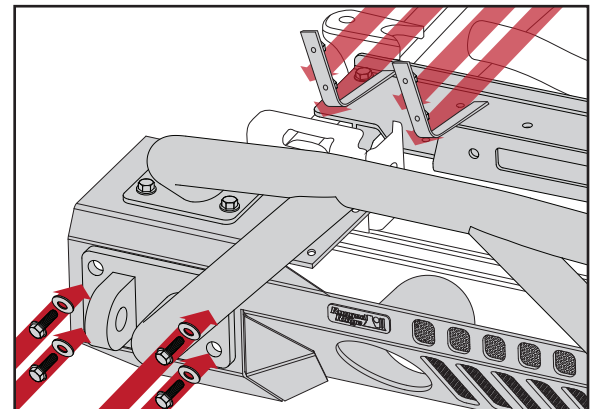



ALUMINUM XHD & ALL TERRAIN BUMPER SERIES

Aluminum XHD & All Terrain Front Bumper (11541.01/.02 & 11542.01/.02)

NOTICE: Some accessories may need to be installed to center section before installing on vehicle

Contents:

- | | |
|---------------------------|--------------------------|
| 1. Bumper Shell | 6. M8 Flat Head Bolt (4) |
| 2. M12x60 Bolt (8) | 7. M8 Washer (4) |
| 3. M12 Washer (8) | 8. M8 Nut (4) |
| 4. M12 Nut Plate (4) | 9. Cover Plate |
| 5. Sheet Metal Screws (8) | |

1. Remove factory front bumper. Twist plug at rear of fog light to disconnect wiring. Unscrew fog lights.

2. Install factory fog lights into center section using sheet metal screws.

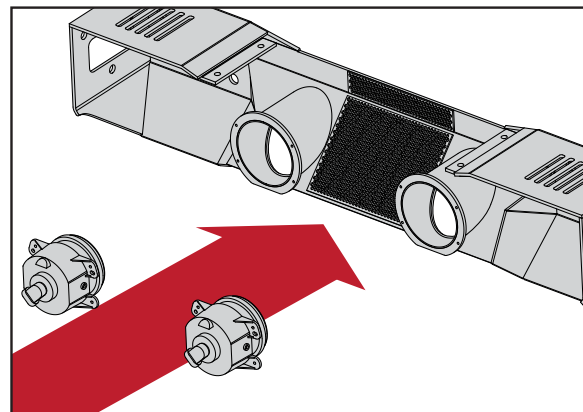

3. Attach cover plate to center section using M8 hardware.

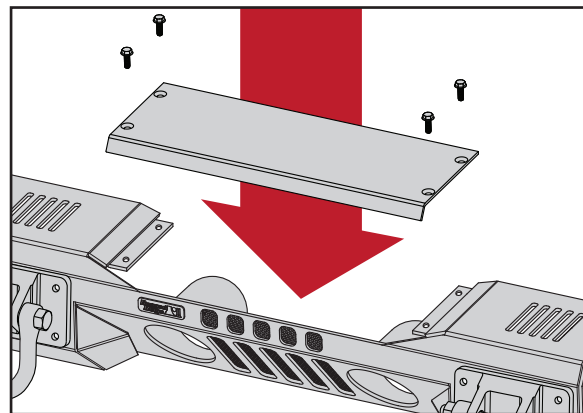



ALUMINUM XHD & ALL TERRAIN BUMPER SERIES

4. Fasten d-rings and center section to frame rails using M12 hardware and nut plates. Tighten evenly. Rubber gaskets included with Aluminum XHD mount between d-rings and center section. Note: D-ring holes are spaced wider at top of bracket.

5. Reconnect fog light wiring plug

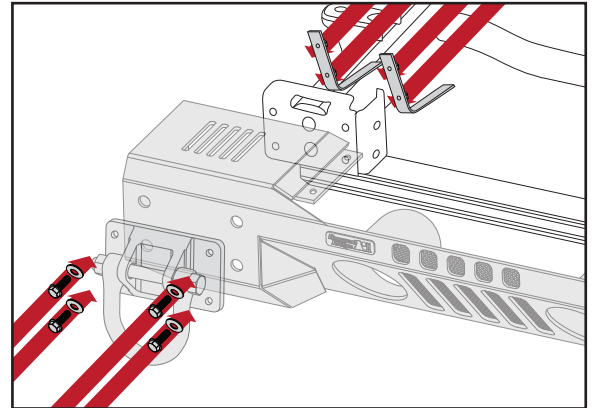



ALUMINUM XHD & ALL TERRAIN BUMPER SERIES

Stubby Ends (11541.10/11542.23)

NOTICE: Bumper should be installed on vehicle prior to stubby end installation

Contents:

1. Stubby End (2)
2. M12 Hex Bolt (6)
3. M12 Washer (12)
4. M12 Lock Nut (6)

1. Remove plastic plugs from sides of center section if present.

2. Attach stubby ends to center section using M12 hardware. Note: Bolt heads should be inside stubby ends and lock nuts inside center section.

