



Sherpa Door Pockets for the '18-present JK/JKU/JT

Installation Instructions

Tools required:
T20 and T27 Torx
Phillips screwdriver
1/16" drill bit and drill

1. Remove the two screws securing the bottom of the door panel to the door and the two screws just below the armrest.

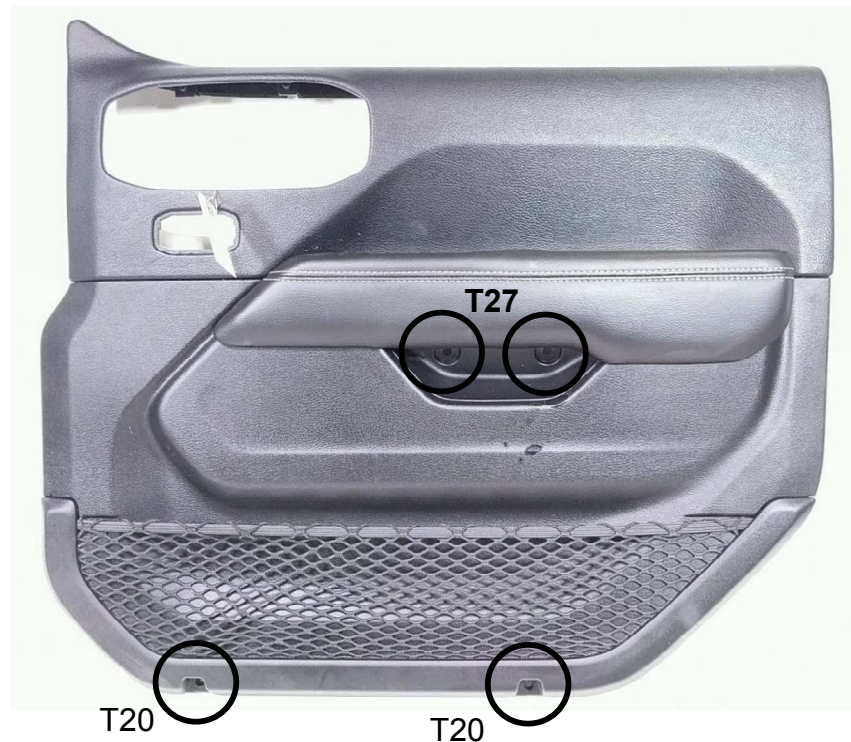

2. Starting at the bottom, pull the panel away from the door. The goal is to pull the lower half of the panel out far enough to release the pins that secure the panel to the door.



3. Slip the door pocket around the bottom of the door panel, making sure the factory push pins go through the holes in the back of the door pocket. The back view of the panel shows the factory push pins going through the holes in the back of the door pockets. You won't see this view when doing the installation because you won't be completely removing the door panel; this photo is shown to illustrate the push pins.



You will need to reach behind the panel to guide the fabric over the pins so the pins go into the holes in the fabric. Once all the pins are through the holes, pull the panel up tight and push the door panel back in place, being careful that the pins go back in the appropriate holes.

In the photo at right the push pin is misaligned with the hole it pushes into. Ensure that all push pins are properly aligned when pushing the door panel back in place.



4. Pull the door pocket up tightly and using a 1/16" drill bit make a hole through one grommet at a time. Insert a screw through that grommet and tighten it into the hole you just drilled. Put screws in the other two grommets the same way.



5. Replace the screws that you removed from the door panel in step 1.