



# WIRE HARNESS INSTALLATION INSTRUCTIONS

For Installing:

Part #10142 – 20 Circuit Weatherproof  
Jeep Harness (74 & earlier)

**Manual #90532**



Perfect Performance Products, LLC

Painless Performance Products Division

2501 Ludelle Street, Fort Worth, Texas 76105-1036

Phone (800) 423-9696

**We have attempted to provide you with as accurate instructions as possible, and are always concerned about corrections or improvements that can be made. If you find any errors or omissions, or if you simply have comments or suggestions concerning these instructions, please write us at the address on the cover and let us know about them, or better yet, send us a fax at (817) 244-4024. We sincerely appreciate your business.**

**Perfect Performance Products, Inc. shall in no event be liable in contract or tort (including negligence) for special, indirect, incidental, or consequential damages, such as, but not limited to, loss of property damage, or any other damages, costs or expenses which might be claimed as a result of the use or failure of the goods sold hereby, except only the cost of repair or replacement.**

**3rd Printing April 2007**

Copyright © 2004 by Perfect Performance Products, Inc.

# Table of Contents

List of Figures.....	ii
List of Tables.....	ii
List of Diagrams.....	ii
1.0 Introduction.....	1
2.0 About These Instructions.....	1
3.0 Contents of the PPPI Wire Harness Kit.....	2
4.0 Tools Needed.....	3
5.0 Pre-Installation and General Guidelines.....	3
6.0 Wire Harness Physical Installation Instructions.....	5
6.1 Rough Installation.....	5
6.2 Harness Attachment.....	6
6.3 Grounding the Jeep.....	6
6.4 Terminal Installation and Making Connections.....	7
6.5 Testing the System.....	7
7.0 General Electrical Systems – All Jeeps.....	7
7.1 Generator Charging System.....	7
7.2 Generator to Alternator Conversion.....	8
7.3 Connecting an Ammeter and the Maxi-Fuse.....	8
7.4 Steering Column Wiring (Turn Signal & Ign. Switch Connectors).....	9
7.5 Interior Lighting.....	12
7.6 HEADLIGHT SECTION A.....	12
7.7 HEADLIGHT SECTION B.....	14
7.8 Instrument Panel.....	14
7.9 Brake Light Switch.....	15
7.10 Tail Section Wiring.....	15
7.11 Helpful Hints for Tail Section Wiring.....	15
8.0 Charging and Ignition Systems (As Originally Manufactured by Jeep).....	15
8.1 1974 and Earlier.....	16
8.1.1 Generator Charging System.....	16
8.1.2 Generator to Alternator Conversion.....	16
8.1.3 Motorola Alternator Charging System.....	17
8.1.4 Delco Ignition (Start/Run) System.....	18
8.2 1975 to 1978.....	19
8.2.1 Motorcraft Alternator (2 configurations).....	19
8.2.2 Delco Alternator – Internal Regulator.....	20
8.2.3 Delco One-Wire Alternator.....	20
8.2.4 Prestolite BID Ignition System (75-77).....	21
8.3 1978 and Newer.....	22
8.3.1 Delco Charging System (1979 and Newer).....	22
8.3.2 Motorcraft Electronic Ignition System.....	22
9.0 Charging and Ignition Systems – Jeeps w/GM Engines Installed.....	24
9.1 Delco Alternator (before 1969) – External Regulator.....	24
9.2 Delco Alternator – Internal Regulator.....	25
9.3 Delco One-Wire Alternator.....	25
9.4 GM Ignition (Start/Run) System.....	25
10.0 Charging and Ignition Systems – Jeeps w/Ford Engines Installed.....	25
10.1 Ford Alternator (2 configurations).....	25
10.2 Ford Ignition (Start/Run) System.....	25
11.0 Charging and Ignition Systems – Jeeps w/Mopar Engines Installed.....	26
11.1 Mopar Alternator.....	26
11.2 Mopar Ignition (Start/Run) System.....	28

12.0	Wire Connection Index and Fuse Requirements.....	29	
12.1	Wire Connection Index.....		29
12.2	Fuse Requirements.....	30	

### List of Figures

3.1	The Painless Wire Harness Kit.....	3
7.1	Ammeter & Maxi-Fuse.....	8
7.2	GM Turn Signal Connectors.....	9
7.3	Interior Lighting.....	10
7.4	HEADLIGHT SECTION A.....	12
7.5	Dimmer Switches.....	13
7.6	HEADLIGHT SECTION B.....	13
7.7	Painless Fan Relay Kit.....	14
8.1	Generator Charging System.....	16
8.2	Motorola Alternator Charging System.....	17
8.3	Maxi-Fuse.....	17
8.4	Delco Ignition (Start/Run) System.....	18
8.5	Motorcraft Alternator Charging System (2 configurations).....	19
8.6	Delco Alternator Charging System (Internal Regulator).....	20
8.7	Prestolite BID Ignition (Start/Run) System.....	21
8.8	Motorcraft Electronic Ignition (Start/Run) System.....	23
8.9	Ford Ignition Diagram (Duraspark II Systems).....	23
8.10	Ford Ignition Switch Connectors.....	24
9.1	Delco Alternator Charging System (External Regulator).....	25
10.1	Ford Ignition (Start/Run) System.....	26
11.1	Mopar Alternator Charging System.....	27
11.2	Mopar Ignition (Start/Run) System.....	28

### List of Tables

7.1	Keyed-Column Ignition and Turn Signal Wiring.....	10
7.2	Mopar Ignition & Turn Signal Wiring #1.....	11
7.3	Mopar Ignition & Turn Signal Wiring #2.....	11
12.1	Wire Connection Index, 1 of 3.....	30
12.1	Wire Connection Index, 2 of 3.....	31
12.1	Wire Connection Index, 3 of 3.....	32
12.2	Fuse Requirements.....	33

### List of Diagrams

Diagram 1	Engine Wiring.....	34
Diagram 2	Instrument Panel Section Wiring.....	35
Diagram 3	Integrated Brake Lights & Separate Turn/Brake Lights.....	36

## 1.0 INTRODUCTION

You have purchased what we at Painless Performance believe to be the most up-to-date and easiest-to-install universal Jeep wire harness on the market. It is designed for easy installation, even if you have no electrical experience. There is enough length to the wire at all engine, dash, and tail locations to complete the installation without splicing. The pre-wired fuse block allows for easy hookup of voltmeter, fuel gauge, oil pressure gauge, temperature gauge, turn signal lights, high beam indicator, and dash lights.

The proper fuses have been pre-installed in the fuse block. In addition, all wires are color-coded and printed. This will help you to identify the different circuits during installation and later on if additions to the overall system are necessary. For fuse specifications and wire color designations, see **Section 12.0**.

The Painless wire harness is designed to be used in Jeeps with a keyed steering column, or non-keyed columns, depending on the kit purchased. All wire is 600 volt, 125°C, TXL. Standard automotive wire is GPT, 300 volt, 80°C, with PVC insulation.

This complete Jeep wiring system has been designed with three major groups incorporated into it:

### **Engine/Headlight Group**

Includes high beam, low beam, park, right turn, left turn, electric fan, horn, starter solenoid and battery feed, alternator and alternator exciter wire, distributor, water temperature, oil pressure and air conditioning.

### **Dash Group**

Includes wires to connect gauges, indicator lights, and switches to their proper sources.

### **Rear Light Group**

Includes tail lights, dome lights, left and right turn signals, brake light and fuel sender.

## 2.0 ABOUT THESE INSTRUCTIONS

### **Important!!!**

Jeep electrical systems are unlike those of the Big Three automobile manufacturers. Generally speaking, GM electrical systems (and Ford and Mopar systems, to a lesser extent) have been uniformly assembled and wired. GM vehicles use GM alternators, Ford vehicles use Ford alternators, and so on.

Furthermore, unlike a GM vehicle (which will accept only a GM engine without extensive modification), many Jeeps have subsequently had GM, Ford, and Mopar engines (and electrical systems) installed in them.

For these reasons you should first be sure you understand the organization of this manual. No confusion should exist as to which parts of this manual apply to YOUR Jeep and which parts do not. Remember, these instructions are designed to accommodate a *universal* Jeep wiring harness, which, in turn, must accommodate the wide variety of electrical configurations found in Jeeps.

You should then identify what type of charging and ignition systems are installed in your Jeep, using these instructions as a guide, and proceed accordingly. At this point, read the **Caution** notice at the beginning of **Section 6.0**.

The contents of these instructions are divided into major **Sections**, as follows:

- 1.0 Introduction
- 2.0 About These Instructions
- 3.0 Contents of the Painless Wire Harness Kit
- 4.0 Tools Needed
- 5.0 Pre-Installation and General Guidelines
- 6.0 Wire Harness Physical Installation Instructions
- 7.0 General Electrical Systems – All Jeeps
- 8.0 Charging and Ignition Systems - As Originally Manufactured by Jeep
- 9.0 Charging and Ignition Systems - Jeeps with GM Engines Installed
- 10.0 Charging and Ignition Systems - Jeeps with Ford Engines Installed
- 11.0 Charging and Ignition Systems - Jeeps with Mopar Engines Installed
- 12.0 Wire Connection Index and Fuse Requirements

The **Sections** are further divided into **Paragraphs** and **Steps**. Throughout, the **Figure** numbers refer to illustrations and the **Table** numbers refer to information in table form. These are located in the back of this manual. Always pay special and careful attention to the **Notes**, especially those in Tables, and ANY text marked **CAUTION**.

**Note:** *Painless Performance has elected to use GM wire color codes throughout this manual. Jeep has changed color codes too many times to make complete and accurate documentation practicable. Painless regrets any inconvenience this may cause.*

### 3.0 CONTENTS OF THE PAINLESS WIRE HARNESS KIT

Refer to **Figure 3.1** to take an inventory to see that you have everything you are supposed to have in this kit. If anything is missing, go the dealer where you obtained this kit or contact Painless Performance at 800-423-9696. The Painless Wire Harness Kit should contain the following items:

- The main harness, with the fuse block wired in and fuses installed.
- 2 Headlamp Connector Cables
- Maxi-Fuse Assembly (Painless Part #80101) (See **Figure 8.3**)
- Firewall Grommet (large) for 1974 and earlier.
- 2 Fender Well Grommets (for Headlamps)
- 2 Packages of Nylon Tie Wraps.
- Parts Box, containing a GM Alternator Connector, Terminals, Splices, etc.
- P/N 90532 Painless Wiring Manual (this booklet).



Figure 3.1 Contents of the Painless Wire Harness Kit

#### 4.0 TOOLS NEEDED

In addition to your regular tools, you will need, at least, the following tools:

- Crimping Tool (*Note: Use a quality tool to avoid over-crimping*)
- Wire Stripper
- Continuity Tester (test light or ohm meter)
- Electric Drill
- 1 ¼" Hole Saw
- Small (10 amp or less) Battery Charger

#### 5.0 PRE-INSTALLATION AND GENERAL GUIDELINES

The installation of your wire harness mainly consists in two parts:

- The physical routing and securing of the wire harness, wires and groups.
- The proper connection of the individual circuits.

These two major tasks are not separate steps, but are integrated together. That is, you will route some wires and make some connections, route some more wire and make some more connections.

We cannot tell you how to physically route the harness in your Jeep. Because of possible modifications to your Jeep, we do offer some routing practices starting in **Section 5.1**, physical installation instructions in **Section 6.0**, and precise instructions concerning the electrical connections you will have to make beginning in **Section 7.0**. To help you begin thinking through the installation of your wire harness, read the following sections:

- 5.1 Familiarize yourself with the harness by locating each of the harness sections in the following list. (Whenever a particular harness section is referred to in these instructions it is shown in "all caps": ENGINE SECTION A) Note that, according to the particular harness you have purchased, some of these sections may not be present, and some are not labeled.

ACCESSORY SECTION SWITCHES  
 ACCESSORY SECTION B+  
 BACKUP SECTION (one wire)  
 BRAKE SWITCH SECTION  
 DIMMER SWITCH SECTION  
 EMERGENCY BRAKE SECTION (one wire)  
 ENGINE SECTION  
 ENGINE SECTION (Single, 10 gauge red wire)  
 ENGINE SECTION A  
 HEADLIGHT SECTION A  
 HEADLIGHT SECTION B  
 IGNITION SWITCH SECTION  
 RADIO SECTION (one wire)  
 TAIL SECTION  
 TURN SIGNAL SECTION

**Note:** For complete information concerning the individual circuits and wires that make up the harness SECTIONS, see Section 12.0. Also see the CAUTION notice at the beginning of Section 6.0.

- 5.2 The Painless wire harness is designed for the fuse block to be mounted on the driver's side, under the dash on early models and to use the factory firewall bulkhead opening in late models.
- 5.3 Decide which of the following circuits you will be using in your system and where the harness groups or wires will be routed:

**Routing Location and Placement**

Emergency Flashers	_____
Horn	_____
Dome Lights	_____
Lights	_____
Cigarette Lighter	_____
Wipers	_____
Air Conditioner	_____
Electric Cooling Fan	_____
Coil	_____
Turn Signals	_____
Radio Ign. Switched B+	_____
Gauges	_____
Accessories	_____
Backup Lights	_____
Cruise Control	_____

- 5.4 Where will the following harness groups be routed?

Headlights	_____
Engine	_____
Dash	_____
Tail Lights	_____



Consider the following guidelines.

- 5.5 A good exercise is to lay out the wire harness on the floor beside your Jeep and identify all the SECTIONS.
- 5.6 You will want to route the harness through and around open areas. Inside edges provide extra protection from hazards and also provide places for tie wraps, clips, and other support.
- 5.7 Route the harness away from sharp edges, exhaust pipes, hood, trunk and door hinges.
- 5.8 Plan where harness supports will be located. Use a support every 12 inches unless the harness routes under the floor carpet.
- 5.9 Allow enough slack in the harness at places where movement could possibly occur (body to frame, frame to engine, etc.).
- 5.10 At wire ends, don't depend on the terminals to support the harness. The weight of the harness could cause terminals to disconnect or copper wire strands to break.
- 5.11 The wires should be bundled into groups. Use nylon ties, poly split loom, or tape.

## 6.0 WIRE HARNESS PHYSICAL INSTALLATION INSTRUCTIONS

**CAUTION: AGAIN REVIEW THE DIFFERENT SECTIONS OF THE PPPI WIRE HARNESS AND THE INDIVIDUAL CIRCUIT CONNECTIONS. SEE TABLE 12-1. IT IS OF THE UTMOST IMPORTANCE THAT YOU DO NOT REMOVE ANY EXISTING WIRING IN THE FOLLOWING AREAS:**

- **Electronic Ignition**
- **Interior Light**
- **Heater/A/C Control**

The preceding list may not be complete, depending upon your particular Jeep. You may, of course, replace existing wiring and/or incorporate the listed areas into your new harness, but this must be done one wire at a time. You may be able to obtain complete wiring diagrams for your Jeep at your local public library, or from publishers such as Chilton's or Mitchell's. These can be of invaluable help.

### 6.1 Rough Installation

**CAUTION: DISCONNECT THE POWER FROM YOUR VEHICLE BY REMOVING THE NEGATIVE (BLACK) BATTERY TERMINAL FROM THE BATTERY.**

**Note: Make no wire connections or permanent mounting of any kind at this time!**

- 6.1.1 Position the fuse block in its mounting area.
- 6.1.2 Drill a 1-1/4" (1.25") hole near the fuse block for engine and headlight group wires to pass through (ENGINE SECTION, ENGINE SECTION A, SINGLE 10-GAUGE red wire #716, and HEADLIGHT SECTION A).

- 6.1.3 Install the firewall grommet. Route engine and headlight group wires through the grommet and position the harness groups in the areas decided upon in **Sections 5.3 and 5.4.**
- 6.1.4 Route dash group (ACCESSORY SECTION B+, ACCESSORY SECTION SWITCHES, HEADLIGHT SECTION B, INSTRUMENT PANEL SECTION, and RADIO SECTION) upward to rear of dash and temporarily tie in place.
- 6.1.5 Position the TAIL SECTION on the floor pan area.

## 6.2 Harness Attachment

**Note:** *Harness routing and shaping is and should be a time-consuming task. Taking your time will enhance the beauty of your installation. Please be patient and TAKE YOUR TIME!*

- 6.2.1 Permanently mount the fuse block using the metal bracket provided.
  - 6.2.2 A silicone based lubricant may need to be added to the weatherproof seal of the fuse block. This will aid in the installation and removal of the fuse block cover.
  - 6.2.3 Mold harness groups to the contour of floor pan, firewall, fender panels, and any other area where wires or harness groups are routed. Remember to route the harness away from sharp edges, exhaust pipes, hood, trunk, and door hinges, etc.
  - 6.2.4 Attach harness groups to your Jeep with clips or ties starting at the fuse block and working toward the rubber grommet for the front groups and along the floor pan for the rear group. The dash wires should be routed out of the way of any under-dash obstacles, such as the cowl vent, air conditioning, radio, etc.
- Note:** *Do not tighten tie wraps and mounting devices at this time. Make all harness attachments LOOSELY.*
- 6.2.4 When used every 1-1/2" or so on the visible areas of the harness, the plastic wire ties make a very secure assembly. A tie installed in other areas every 6" or so will hold the wires in place nicely. Remember to take your time!

## 6.3 Grounding the Jeep

A perfectly and beautifully wired Jeep will nonetheless have bugs and problems if everything is not properly grounded. Do not go to the careful effort of installing a quality wire harness only to neglect proper grounding.

**Note:** *The Painless wire harness kit includes no ground wire except the black wire from the two headlamp connectors. You must supply ground wire (14-16 gauge) for all circuits. If ground wire is needed, we suggest using the excess wire cut off from the harness.*

- 6.3.1 Connect a Ground Strap or Cable (even a 10-gauge wire is too small) from the Negative Battery terminal to the Jeep chassis (frame).
- 6.3.2 Connect a Ground Strap from the engine to the chassis. DO NOT RELY UPON THE MOTOR MOUNTS TO MAKE THIS CONNECTION.
- 6.3.3 Connect a Ground Strap from the engine to the body.
- 6.3.4 If you have a fiberglass body you should install a terminal block (Painless Part #40026) to ground all of your gauges and accessories. Ground the terminal block and everything connected to it will be grounded.

## 6.4 Terminal Installation and Making Connections

**Note:** *In the following steps you will be making the circuit connections. Before you start, you should carefully read Sections 7.0 through 11.0, as appropriate, and continually refer to Section 12.0, DOUBLE-CHECKING your routing and length calculations before cutting any wires and making connections. GIVE SPECIAL ATTENTION TO TURN SIGNAL AND IGNITION SWITCH CONNECTIONS. THESE CAN BE CONFUSING.*

- 6.4.1 Have all needed tools and connectors handy.
- 6.4.2 Select the correct size terminal for the wire and stud application.
- 6.4.3 Determine the correct wire length and cut the wire. Remember to allow enough slack in the harness and wires at places where movement could possibly occur, such as Jeep body to frame, frame to engine, etc. **Double-check your calculations.**
- 6.4.4 Strip insulation away from wire. Strip only enough necessary for the type of terminal lug you are using.

**Note:** *In the following step, make sure that the terminal is crimped with the proper die in the crimping tool. An improper crimp will NOT make a good connection.*

- 6.4.5 Crimp the terminal onto the wire. CAUTION: DO NOT OVER-CRIMP!
- 6.4.6 Connecting the harness throughout the groups is a redundant process. Make sure that each wire is FIRST properly routed and THEN attach. DO NOT ATTACH FIRST THEN ROUTE AFTERWARDS.
- 6.4.7 When all wires are attached, tighten the mounts and ties to secure harness permanently.

## 6.5 Testing the System

- 6.5.1 Use a small (10 amp or less) battery charger to power up the vehicle for circuit testing. If there is a problem anywhere, the battery charger's low amperage and internal circuit breaker will provide circuit protection.

**CAUTION:** *IF YOU HAVE NOT YET DISCONNECTED THE BATTERY FROM THE JEEP, DO SO NOW! DO NOT CONNECT THE BATTERY CHARGER WITH THE BATTERY CONNECTED.*

Connect the battery charger's NEGATIVE output to the Jeep chassis or engine block and its POSITIVE output to the Jeep's positive battery terminal.

- 6.5.2 INDIVIDUALLY turn on each light, ignition, wiper circuit, etc. and check for proper operation.
- 6.5.3 When all circuits check out THEN attach the battery cable to the battery for vehicle operation.

## 7.0 GENERAL ELECTRICAL SYSTEMS – ALL JEEPS

- 7.1 Generator Charging System. Use Paragraph 8.1.1.

7.2 Generator to Alternator Conversion. Use Paragraph 8.1.2.

7.3 Connecting an Ammeter and the Maxi-Fuse. See Figure 7.1.

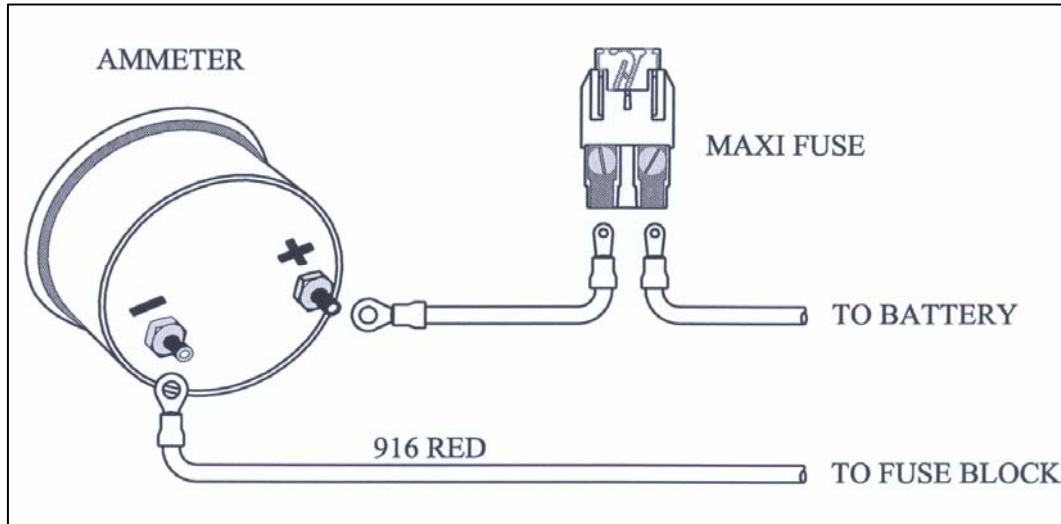

Figure 7.1 Ammeter & Maxi-Fuse

- 7.3.1 The Ammeter must be inserted IN SERIES onto the ENGINE SECTION (single 10-gauge red wire #716) that routes from the Fuse Panel to the Starter Solenoid (Starter Relay if you have a Ford or Mopar starter system).
- 7.3.2 The overall physical length of this circuit should be as short as possible (allow some slack, however). You may have to cut wire #716 and you may have to add some additional length of 10-gauge wire. USE ONLY 10-GAUGE WIRE.
- 7.3.3 Route wire #716 (from the Fuse Panel) and connect to the Ammeter NEGATIVE terminal. To complete the installation, follow ONE of the next three paragraphs, as appropriate.
- 7.3.4 If you are using a Delco Starter, route the remainder of wire #716 from the Ammeter POSITIVE terminal to the Starter Solenoid Battery (B+) terminal. This is the terminal to which the battery cable is connected. Splice the Maxi-Fuse (Figure 8.3) onto the end of wire #716 and connect to the Starter Solenoid Battery (B+) terminal.
- 7.3.5 If you are using a Ford starter relay, route the remainder of wire #716 from the Ammeter POSITIVE terminal to the Starter Relay Battery (B+) terminal. This is the terminal to which the battery cable is connected. Splice the Maxi-Fuse (Figure 8.3) onto the end of wire #716 and connect to the Starter Relay Battery (B+) terminal.
- 7.3.6 If you are using a Mopar starter relay, route the remainder of wire #716 from the Ammeter POSITIVE terminal to the Starter Relay Battery (B+) terminal, and from this terminal to the Starter Solenoid Battery (B+) terminal. This is the terminal to which the battery cable is connected. Splice the Maxi-Fuse (Figure 8.3) onto the end of wire #716 and connect to the Starter Solenoid Battery (B+) terminal.

**CAUTION:** BOTH AMMETER TERMINALS MUST BE ABSOLUTELY ISOLATED FROM GROUND. IF EITHER AMMETER TERMINAL COMES IN CONTACT WITH GROUND A HARNESS FIRE IS INEVITABLE. USE EXTREME CARE AND DILIGENCE IN CONNECTING AMMETERS.

**CAUTION:** *BE SURE YOUR AMMETER'S CURRENT (AMPS) RATING EXCEEDS THE CURRENT OUTPUT OF YOUR ALTERNATOR. PERFECT PERFORMANCE PRODUCTS, INC. DOES NOT RECOMMEND USING ANY AMMETER RATED AT LESS THAN 65 AMPS. DO NOT USE AN AMMETER WITH ANY HIGH-OUTPUT ALTERNATOR (MORE THAN 65 AMPS). WE SUGGEST USING A VOLT METER INSTEAD.*

**7.4 Steering Column Wiring – Turn Signal & Ignition Switch Connectors. See Figure 7.2 and Table 7.1.**

**7.4.1** There are two different plugs on most tilt columns. The difference is in the length of the male plug that is mounted ON THE COLUMN. One plug is 3-7/8" (3.875") long and the other is 4-1/4" (4.250"). This is only a difference of 3/8" (0.375"), so measure the plug carefully. See **Figure 7-2** to determine which female connector is correct for your automobile. If your vehicle has a GM style column you will need the **Painless Column Kit Part#30806**.

The TURN SIGNAL SECTION wires will need to be cut to length and the terminals installed. Choose the proper plug and install the terminals according to **Table 7-1**, as shown in **Figure 7-2**. The GM wire color codes have been included for reference.

**Note:** *The terminals will only insert into the connector ONE WAY, as shown in Figure 7-2. Make certain you are inserting the wire into the CORRECT LOCATION as the terminals are difficult if not impossible to remove once inserted.*

**7.4.2** See **Table 7-1** and **Figure 7-2** for color codes, wire numbers, and wire designations for the Ignition Switch Connectors.

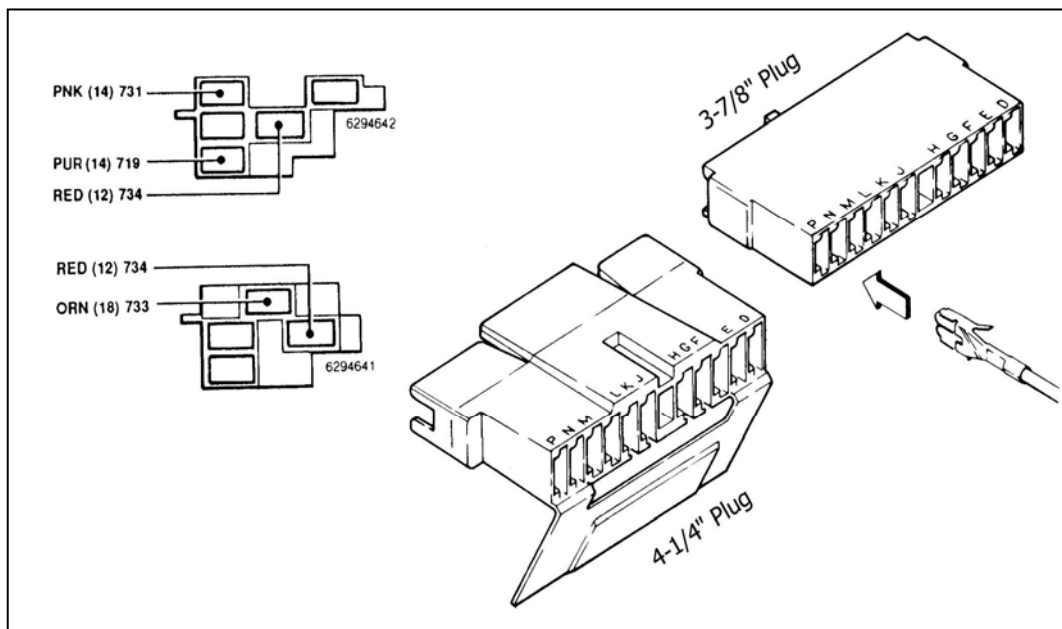

**Figure 7.2 GM Turn Signal Connectors**

7.4.3 **IGNITION SWITCH SECTION** wire #719 (pur) needs to be connected to the Neutral Safety Switch at the base of the steering column, if using a GM column with a shift handle. If using a neutral safety switch on a floor shifter or in the transmission, the (pur) #719 needs to be routed to the neutral safety switch, cut and connected to it, then continued on to the starter solenoid.

7.4.4 The harness does not support seat belt buzzers or key alarms.

**NOTE:** To supply power to a throttle body or tuned port fuel injection use **ENGINE SECTION A** wire #720 (pnk) as the fused ignition power source.

TURN SIGNAL SECTION				
GM Color	Designation	Painless Wire #	Painless Color	Turn Signal Connector
Blk	Horn	753	Blk	G
LtBlu	LF Turn Signal	726	LtBlu	H
DkBlu	RF Turn Signal	725	Blu	J
Brn	Hazard Flasher	751	Brn	K
Pur	Turn Flasher	752	Pur	L
Ylw	LR Turn Signal	749	Ylw	M
Grn	RR Turn Signal	748	Grn	N
Wht	Stop Lamp Switch	718	Wht	P

IGNITION SWITCH SECTION				
GM Color	Designation	Painless Wire #	Painless Color	Turn Signal Connector
Pur/Wht	Ignition Start	719	Pur	
Orn	Ignition Switched B+	733	Orn	
Red	Battery B+	734	Red	

Table 7.1 Keyed-Column Ignition and Turn Signal Wiring

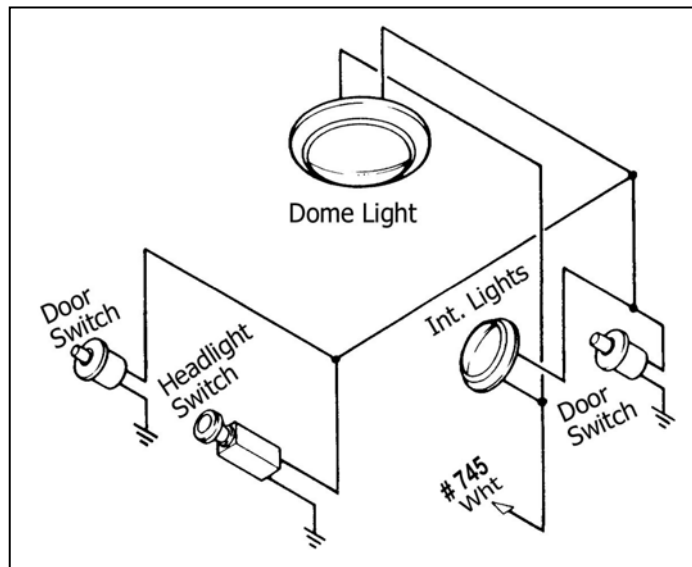

Figure 7.3 Interior Lighting

## 1970-74 WITHOUT TILT COLUMN

### TURN SIGNAL CONNECTOR

Mopar Color	Designation	Painless Wire No.	Painless Color
Wht	Stop Light Switch	718	Wht
Tan	RF Turn Signal	725	Blu
Grn	LF Turn Signal	726	Lt.Blu
Brn	RR Turn Signal	748	Grn
Grn	LR Turn Signal	749	Ylw
Pnk	Hazard Flasher	751	Brn
Red	Turn Flasher	752	Pur
Blk	Horn	753	Blk

### IGNITION SWITCH CONNECTOR

Ylw <sup>1</sup>	Ignition Start	719	Pur
Brn	Ignition Coil	731	Pnk
Blk	Accessory Fuse Panel	732	Brn
Blu	Ignition Switched Fuse Panel	733	Orn
Red	Battery B+	734	Red
Vio	Ground	----	----
Ylw <sup>2</sup>	Buzzer Switch	3	----
Ylw <sup>2</sup>	Buzzer Switch	3	----
Orn	Gear Shift Lamp	3	----

- NOTES:**
1. 12-gauge wire
  2. 20 gauge wire
  1. The Painless harness does not support these.

Table 7.2 Mopar Ignition & Turn Signal Wiring #1

### TURN SIGNAL CONNECTOR

Designation	79 w/tilt	79 w/o tilt	82 RWD w/o tilt	82 RWD w/tilt
Stop Light	Wht	Wht	Wht	Wht
RR Turn Signal	Dk.Grn	Brn	Brn/Red	Brn/Red
LR Turn Signal	Ylw	Dk.Grn	Dk.Grn/Red	Dk.Grn/Red
Turn Signal Flasher	Pur	Red	Red	Red
Hazard Signal Flasher	Brn	Pnk	Pnk	Pnk
RF Turn Signal	Dk.Blu	Tan	Tan	Tan
LF Turn Signal	Lt.Blu	Lt.Grn	Lt.Grn	Lt.Grn
Horn	Blk	Blk	Blk/Red	Blk/Red

#### Not supported by the Painless wire harness:

Horn	----	Blk/Red	----	----
Horn Ground	----	Blk	Blk	----
Key Alarm	Pnk	----	Blk/Lt.Blu	----
Key Alarm	Blk	----	Lt.Blu	----
R Corner Lamp	Blk/Wht	Tan/Wht	Tan/Wht	Tan/Wht
L Corner Lamp	Gry	Lt.Grn/Blk	Lt.Grn/Blk	Lt.Grn/Blk
Corner Feed Lamp	Brn	Vio	Vio	Vio

Table 7.3 Mopar Ignition & Turn Signal Wiring #2

## 7.5 Interior Lighting. See Figure 7.3.

- 7.5.1 Interior Lights are switched through the door switches and the dash-mounted headlight switch, which is usually rotated counter-clockwise to turn on. These switches apply ground to the circuit. **YOU WILL NEED TO SUPPLY THESE GROUND WIRES.** 12V is continually present at the light bulbs.
- 7.5.2 If possible leave your existing interior light wiring intact. The Painless harness supplies the 12V feed (B+) to the circuit via TAIL SECTION wire #745 (wht) and a ground via TAIL SECTION wire #761 (blk).

## 7.6 HEADLIGHT SECTION A. See Figure 7.4.

- 7.6.1 Connect HEADLIGHT SECTION A wire #724 (grn) to the Horn's hot terminal. TURN SIGNAL SECTION wire #753 (blk) was connected in the Turn Signal Connector section of these instructions. The Horn Relay is pre-wired into the Fuse Panel. Mount it next to the Fuse Block using the self-tapping screw provided.
- 7.6.2 Connect HEADLIGHT SECTION A wires #708 (lt.grn) and #709 (tan) to the green and tan wires of BOTH Headlamp Connectors. Connect the black wires of the Headlamp Connectors to Chassis Ground. You should have enough wire to accomplish this. You have been supplied with two small grommets should you need to pass these wires through a fender well. Don't forget to thread them onto the wires BEFORE you connect the wires.
- 7.6.3 Connect HEADLIGHT SECTION A wire #727 (brn) to ALL front Park Lights. Connect HEADLIGHT SECTION A wire #725 (blu) to the RIGHT FRONT Turn Signal. Connect wire #726 (lt.blu) to the LEFT FRONT Turn Signal.

**Note:** Don't confuse Park Lights with Turn Signals.

- 7.6.4 Connect HEADLIGHT SECTION A wire #701 (gry/wht) to the Electric Fan Relay. This wire is an activation wire for the relay, **NOT A POWER FEED.** The other end of wire #701 is in the ACCESSORY SECTION SWITCHES and should be connected to the electric fan switch in the dash. **Figure 7.7** shows a typical fan relay installation.

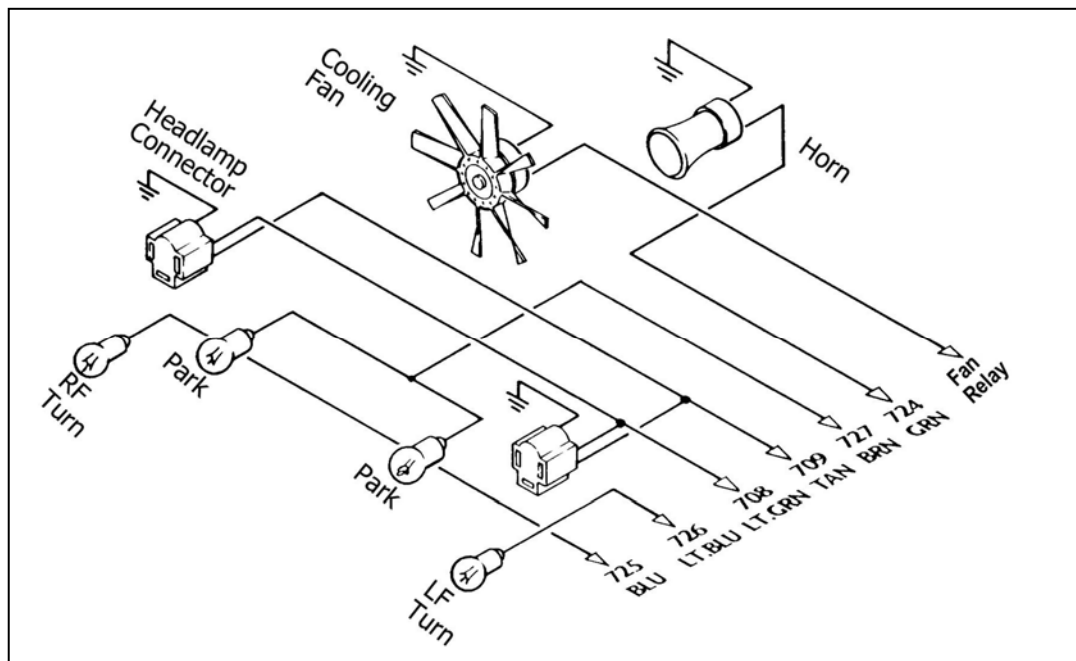

Figure 7.4 HEADLIGHT SECTION A



*Note: The wire going to the fan in Figure 7.4 will be coming from the fan relay output terminal. Wire #701 (gry/wht) from the ACCESSORY SECTION SWITCHES is an activation wire for the fan relay.*

- 7.6.5 Connect the DIMMER SWITCH SECTION cable to its mating connector in the harness (if applicable) and your floor-mounted Dimmer Switch or column-mounted Dimmer Switch.

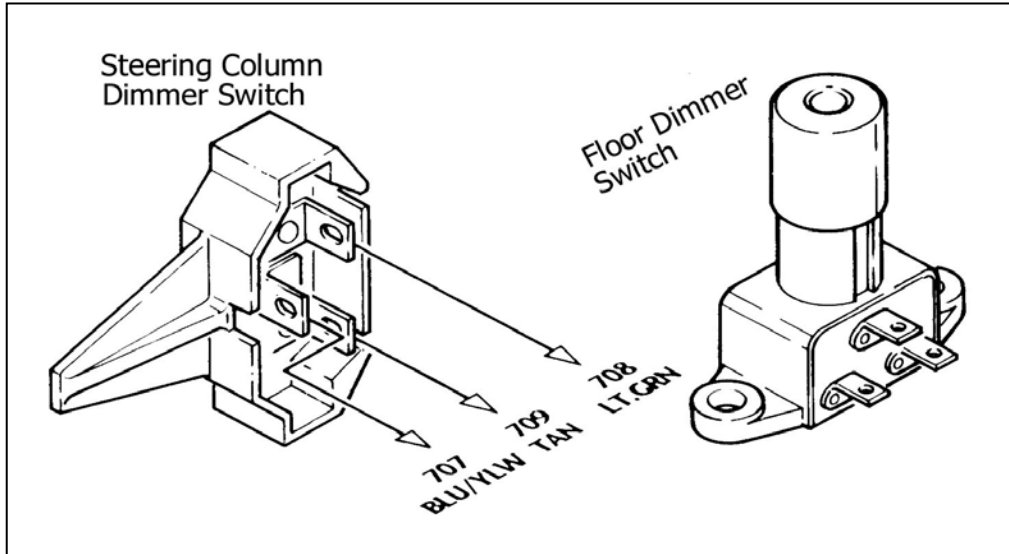

Figure 7.5 Dimmer Switches (Push Button Style – Painless Part #80150)

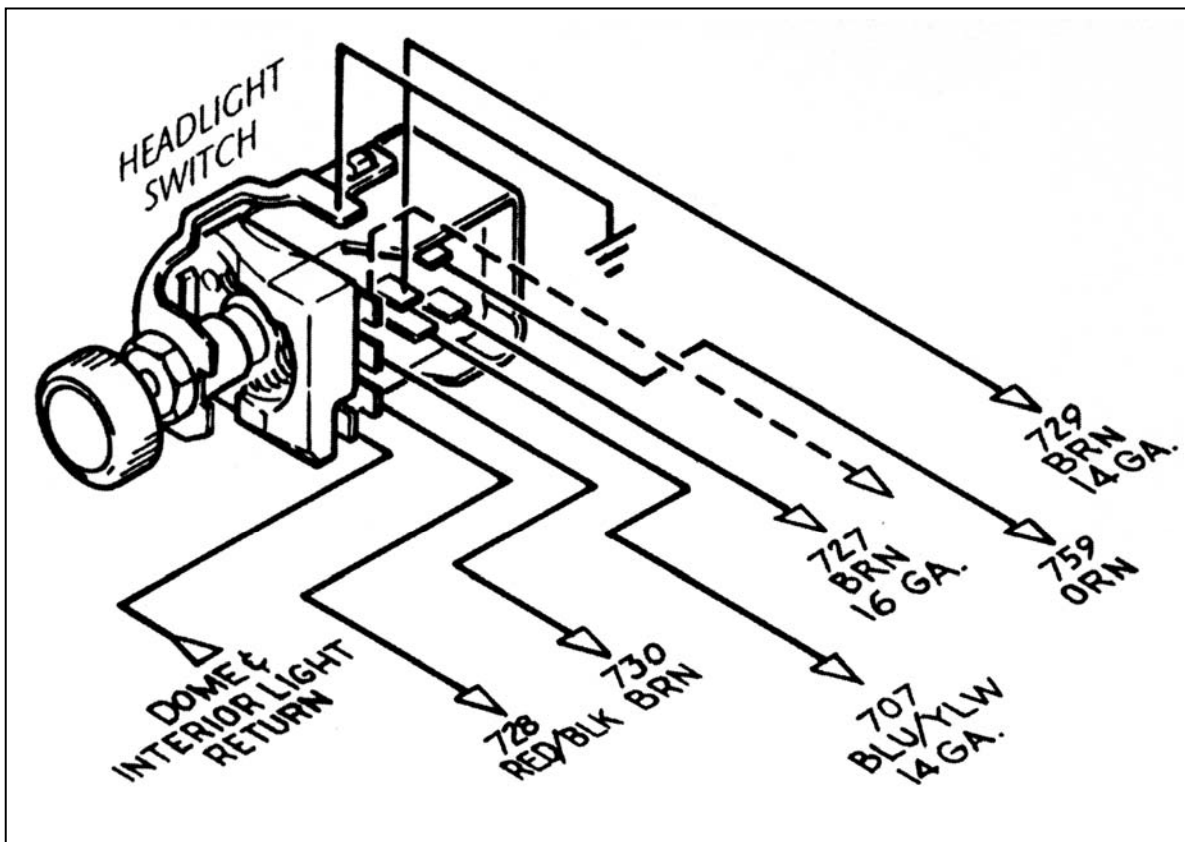

Figure 7.6 HEADLIGHT SECTION B (GM Style – Painless Part #80152)

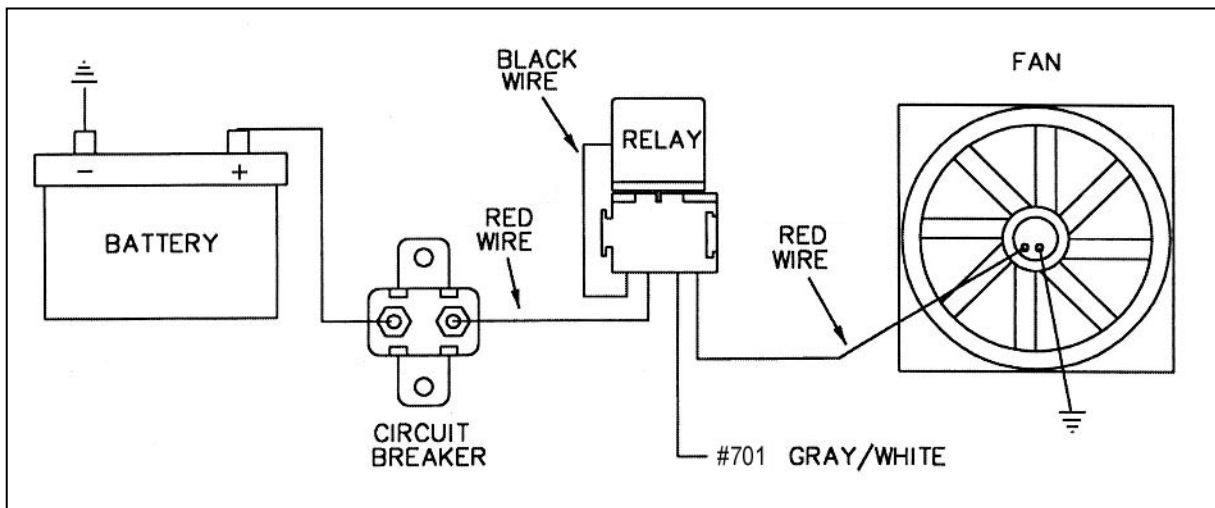

Figure 7.7 Painless Fan Relay Kit (Part #30101)

## 7.7 HEADLIGHT SECTION B Wiring. See Figure 7-6.

7.7.1 Connect the 6 wires of HEADLIGHT SECTION B, the Dome and Interior Light return circuit, and the Headlamp Switch Ground as shown. If you do not have a GM headlight switch, you should trace out the wires of your existing harness and connect the new harness according to **Table 11-2**.

*Note: On late-style GM headlight switches, the park lights terminal to which wire #727 (brn) is connected (shown in Figure 7-6) has been omitted. In this case, wire #727 must be connected as indicated by the dashed line in Figure 7-6.*

## 7.8 Instrument Panel

7.8.1 Connect the wires of the INSTRUMENT PANEL SECTION as indicated in **Table 11-2**. Insulate and stow any wires you do not use.

7.8.2 Connect a jumper from wire #735 (red/wht) to all Gauges' power or "I" terminals. Connect a jumper from wire #730 (brn) to all Gauges' Instrument Lighting terminals. Connect a jumper to all Gauges' Ground terminals and connect to Chassis Ground.

7.8.3 Install the #721 pur/wht temperature gauge sender wire on the single long post on back of the temperature gauge.

*Note: These terminals were originally a push on terminal and now are an eyelet terminal. Nuts to attach each terminal are provided in the parts kit.*

7.8.4 Install the #739 pnk wire on the fuel gauge post closest to the glove box and secure with a nut.

7.8.5 Attach the blk wire to a good ground such as a cluster mounting screw.

- 7.8.6 Install the #735 (red/wht) wire of the voltmeter to the driver's side terminal and the blk wire to the passengers side terminal of the voltmeter and secure with nuts.
- 7.8.7 Install the #722 (lt.blu/blk) oil gauge wire to the terminal of the oil gauge and secure with nuts. Re-install the dash cluster assembly.

## 7.9 Brake Light Switch

- 7.9.1 Connect ENGINE SECTION A wires #717 (orn) and #718 (wht) to the Brake Light Switch wherever it may be mounted.
- 7.9.2 The Third Brake Light wire is pre-connected on the Switch end. Connect TAIL SECTION wire #750 (orn) to the Third Brake Light if applicable.

## 7.10 Tail Section Wiring

- 7.10.1 Connect the wires of the TAIL and TURN SIGNAL SECTIONS as indicated in **Table 11-2** with the exception of #718 (wht), #748 (grn), #749 (ylw) and #750 (orn).
- 7.10.1 These 4 wires will be connected according to one of the diagrams shown in **Diagram 3**. Which diagram you will use depends on whether or not you have one bulb on each side of the vehicle that is for the brake and Turn Signal Lights (this is referred to as integrated lights) or you have more than one bulb on each side and the Brake and Turn Signal Lights are hooked to different bulbs (referred to as separate Brake/Turn Lights).

**Note A:** *If you have Integrated Brake Lights you must use bulbs that have two (2) filaments in them such as in an 1157 bulb.*

**Note B:** *The three wires shown in these diagrams are connected to the "brighter" of the two filaments when using a two-filament bulb (the Tail Lights are usually connected to the "Dimmer" filament). The Tail Lights, License Plate Lights, Reverse Lights, etc. are not shown on the diagrams for clarity.*

**Note C:** *In the separate Brake Light diagram the arrangement shown is only one of several ways to wire a vehicle. The important thing is that the Brake and Turn Signal Lights use completely separate bulbs.*

## 7.11 Helpful Hints for Tail Section Wiring

- 7.11.1 When you have Integrated Brake Lights on your vehicle the Turn Signal switch acts as a brain to control when the Lights in the rear are on constantly (braking) or flashing (turning) or a combination of both. **The Turn Signal switch you use must be built to do this! If you are using a steering column out of a salvage yard that was originally in a vehicle that had Separate Brake Lights then the switch will not work for Integrated Brake Lights.**
- 7.11.2 Almost all light bulbs get the ground they need through the socket housing. If you mount your socket housing into anything other than a grounded metal part then you will need to provide a separate ground wire.

## 8.0 CHARGING AND IGNITION SYSTEMS – AS ORIGINALLY MANUFACTURED BY JEEP

**CAUTION: IF YOU ARE USING A HIGH AMPERAGE (65 AMPS OR HIGHER) ALTERNATOR SEE SPECIAL INSTRUCTION SHEET PP-662W INCLUDED IN THIS KIT. IF YOU DID NOT GET THIS, PLEASE CALL THE TECH LINE AT 800-423-9696 OR SEND AN E-MAIL TO [TECH@PAINLESSPERFORMANCE.COM](mailto:TECH@PAINLESSPERFORMANCE.COM).**

## 8.1 1974 and Earlier

### 8.1.1 Generator Charging System. See Figure 8.1.

- A. Connect Generator ARMATURE terminal (A) to Voltage Regulator terminal A. Connect Generator FIELD terminal (F) to Voltage Regulator terminal F. Use 14-gauge wire (color optional).
- B. Be sure both the generator and the voltage regulator are securely grounded. The voltage regulator may have a terminal for this purpose (labeled "G") or you may have to ground the regulator case.
- C. Connect ENGINE SECTION wire #715 (red) to Voltage Regulator terminal B.
- D. Insulate and stow ENGINE SECTION wire #714 (wht).

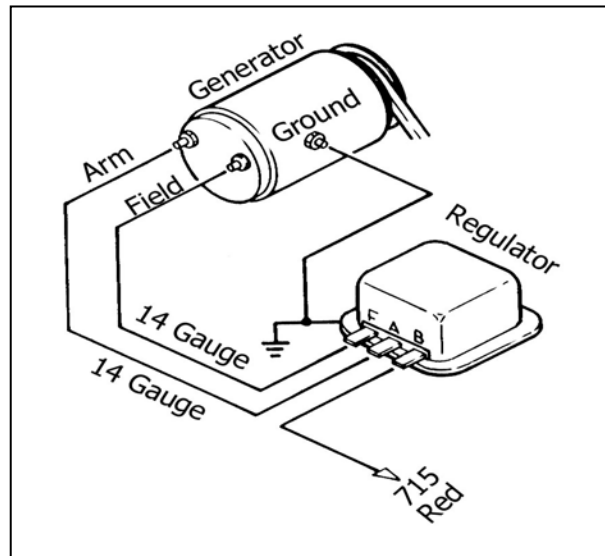

**Figure 8.1** Generator Charging System

### 8.1.2 Generator to Alternator Conversion

- A. You can convert your generator charging system to use an alternator and external regulator without altering or re-routing existing wires. You will need to obtain an externally regulated alternator and a compatible voltage regulator.
- B. Install the new alternator and replace the existing generator voltage regulator with the new, alternator-compatible one.

- C. Connect the existing wiring according to either **Section 8.0, 9.0, 10.0, or 11.0**, as appropriate.

**8.1.3 Motorola Alternator Charging System. See Figure 8.2.**

- A. Locate the Alternator Voltage Regulator. It may not appear exactly as represented.
- B. Find the one wire that connects from the Voltage Regulator to the Starter Relay. Disconnect this wire from the Relay and splice it to wire #714 (wht). LEAVE THE REMAINING VOLTAGE REGULATOR WIRES INTACT in their original configuration. You may replace them, ONE AT A TIME, and incorporate them into the new harness, if you wish.
- C. Connect wire #715 (red) to the Alternator Battery/Output terminal.

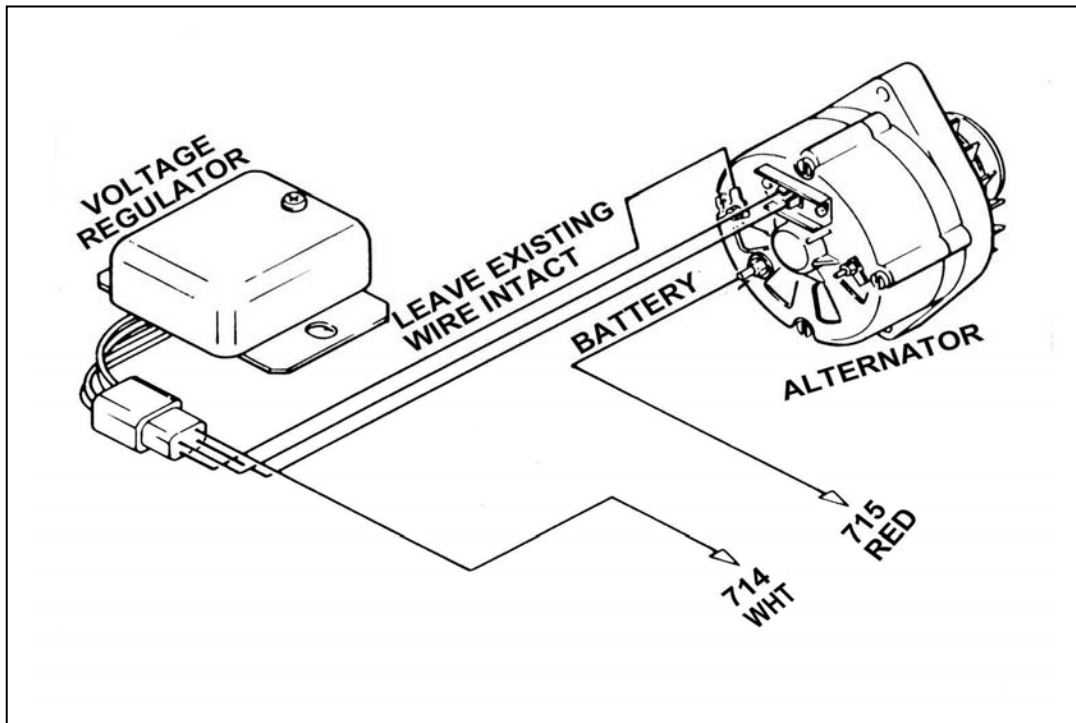

Figure 8.2 Motorola Charging System

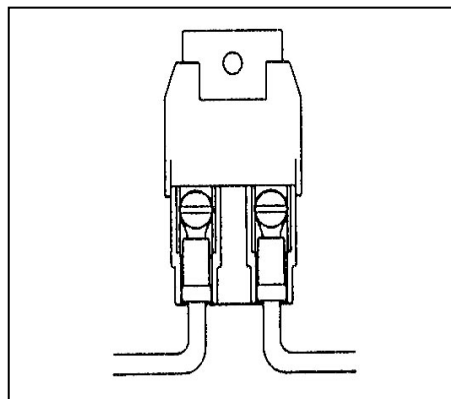

Figure 8.3 Maxi-Fuse

#### 8.1.4 Delco Ignition (Start/Run) System. See Figure 8.4.

**Note:** *If you are going to install an ammeter, see Section 7.3 first.*

- A. With crimping tool, attach Maxi-Fuse (**Figure 8.3**) onto end of ENGINE SECTION (single 10-gauge red wire #716) after having routed wire from the Fuse Panel to the Starter Solenoid. **DO NOT OMIT IT!**
- B. Connect wire #716 – with Maxi-Fuse installed – to the Starter Solenoid Battery terminal. This is the same lug to which the large red cable from the battery is normally connected.
- C. Connect ENGINE SECTION A wire #719 (pur) to the Starter Solenoid Start (S) terminal.
- D. If you are using the Ballast Resistor, mount it away from other wiring or hoses. The ballast resistor gets very hot during operation. Connect ENGINE SECTION A wire #720 (pnk) to one end of the Ballast Resistor. Connect the other end of the Ballast Resistor to the Ignition Coil POSITIVE (+) terminal with 14-gauge wire (you may have enough pink wire left over to accomplish this). If you are not using a Ballast Resistor, connect wire #720 directly to the Ignition Coil POSITIVE (+) terminal.

**Note:** *For GM HEI systems route wire #720 (pnk) to the Distributor Cap and attach it to the terminal labeled BAT. No Ballast Resistor is required, unless manufacturer specifies.*

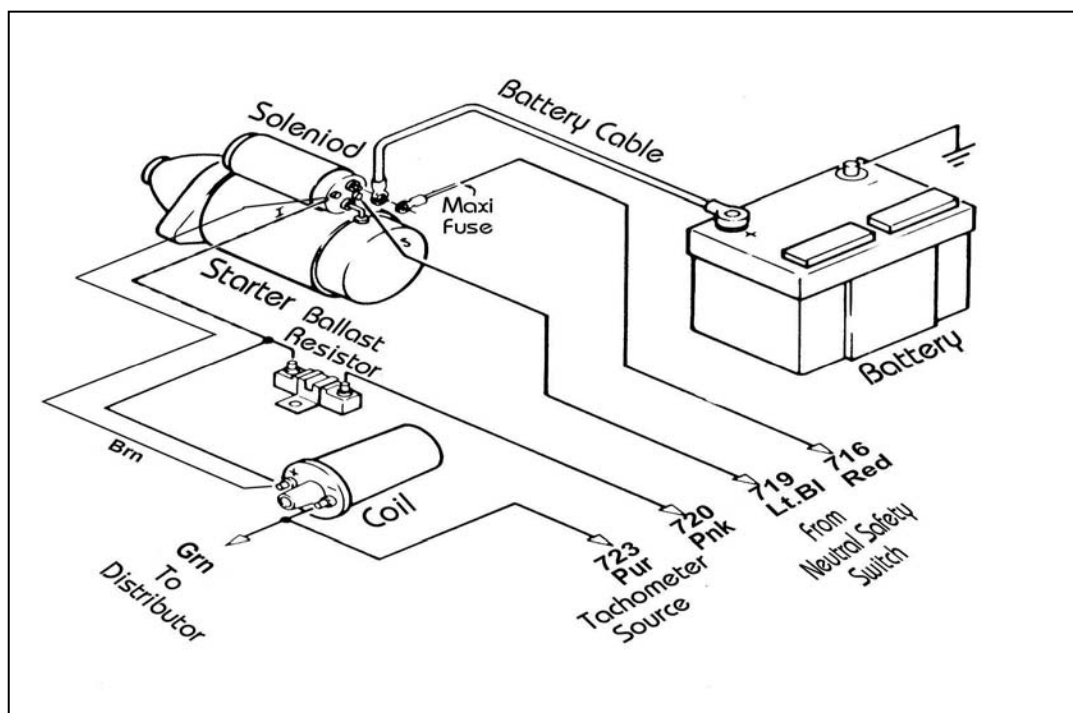

**Figure 8.4** Delco Ignition (Start/Run) System

- E. The Ignition Coil NEGATIVE (-) terminal is connected to the Distributor. Also connect ENGINE SECTION A wire #723 (pur/wht) to the Ignition Coil NEGATIVE (-) terminal. This is the tachometer source. If you are not using a tachometer, insulate and stow wire #723.

- F. A 14-gauge wire connected from the Starter Solenoid Ignition (I) terminal to the ignition coil side of the Ballast Resistor is optional. This wire (in **Figure 8.4**) serves as a Ballast Resistor BYPASS during engine starting. However, if the starter solenoid shorts out, which is not unusual, the engine will stop running and will not restart as long as this wire is connected. You may therefore choose to omit it. If you are not using a Ballast Resistor, leave the Starter Solenoid Ignition (I) terminal unconnected and do not install the bypass wire.

## 8.2 1975 to 1978

*Note: 1975-1978 could have either Motorcraft or Delco systems installed.*

### 8.2.1 Motorcraft Alternator (2 configurations). See Figure 8.5.

*Note: Your Alternator may not appear exactly as represented in Figure 8.5. The circuits are wired the same way, though.*

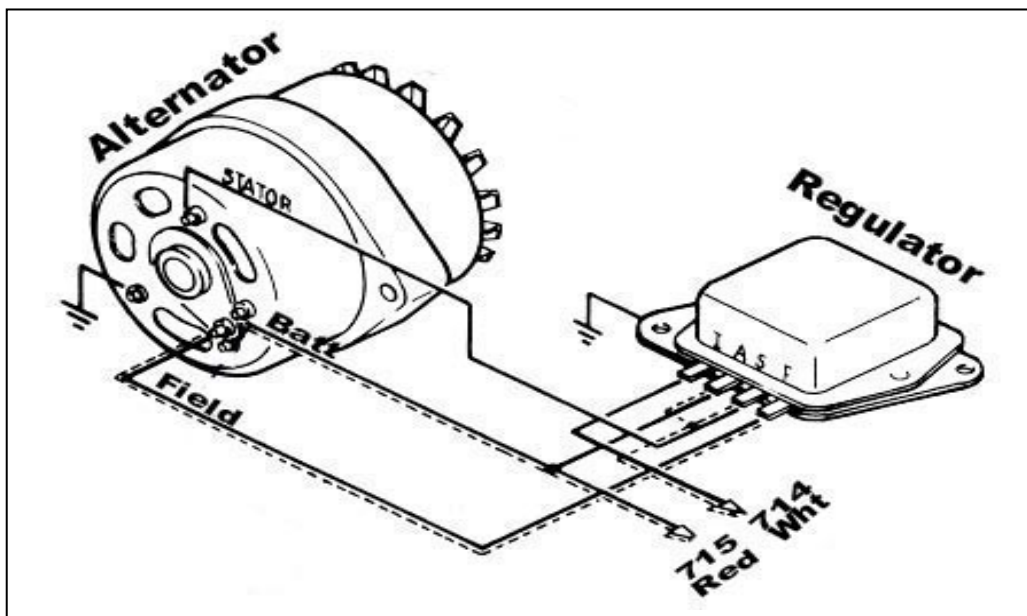

**Figure 8.5** Motorcraft Alternator (2 configurations)

- A. Connect ENGINE SECTION wire #715 (red) to the Alternator Output lug (Bat). Connect ENGINE SECTION wire #714 (wht) to the Voltage Regulator (I) terminal.
- B. Connect a 14-gauge wire from the Voltage Regulator A terminal to the Alternator Output lug (Bat).
- C. Connect a 14-gauge wire from the Voltage Regulator S terminal to the S terminal of Alternator. Connect a 14-gauge wire from the Voltage Regulator F terminal to the Alternator Field (F) terminal.
- D. Connect the Alternator Ground lug and the Voltage Regulator to chassis ground.

- E. An alternate (and less-used) method is to omit the Alternator Stator (S) wire, install a 14-gauge jumper across Voltage Regulator terminals A and S, and connect wire #714 to either the A or S terminal on the Voltage Regulator. The FIELD wire and wire #715 are connected as above. Do **NOT** install a jumper as in **Section 8.2.1, Step B**. The Voltage Regulator Ignition (I) terminal is not connected. Install ground wires as in **Section 8.2.1, Step D**. This alternate configuration is illustrated in dashed lines in **Figure 8.5**.

**8.2.2 Delco Alternator – Internal Regulator. See Figure 8.6.**

- A. Connect ENGINE SECTION wire #714 (wht) to Alternator terminal 1. Connect ENGINE SECTION wire #715 (red) to the Alternator Output lug (Bat).
- B. Connect a short 14-gauge jumper wire from Alternator terminal 2 to the Alternator Output lug (Bat).
- C. A connector and terminal spades for late GM Alternators are included in the parts box.

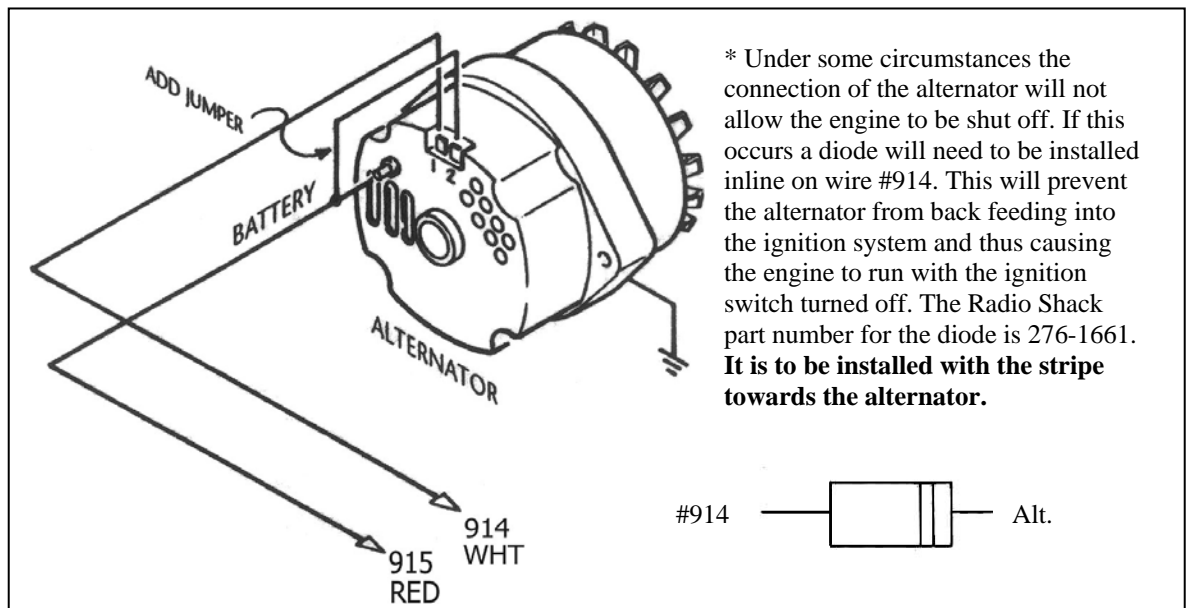

**Figure 8.6** Delco Alternator (Internal Regulator)

**8.2.3 Delco One-Wire Alternator**

- A. Connect ENGINE SECTION wire #715 (red) to the Alternator Output lug (Bat).
- B. Insulate and stow ENGINE SECTION wire #714 (wht). Do not install jumper wire. No wires are connected to Alternator terminals 1 & 2.
- C. When using a 1-wire alternator you must use a voltmeter or ammeter. A warning light cannot be wired in.



## 8.2.4 Prestolite BID Ignition System (1975-1977). See Figure 8.7

**Note:** *If you are going to install an ammeter, see Section 7.3 first.*

- A. Locate the Electronic Control Unit. It may not appear exactly as represented. All wires connected to this unit **MUST REMAIN CONNECTED IN THEIR ORIGINAL CONFIGURATION**. You may replace them, one at a time, and incorporate them into the new harness, if you wish.
- B. With crimping tool, attach Maxi-Fuse (**Figure 8.3**) onto end of ENGINE SECTION (single 10-gauge red wire #716) **AFTER** having routed wire from the Fuse Panel to the Starter Relay. **DO NOT OMIT IT!**
- C. Connect wire #716 – with Maxi-Fuse installed – to the Starter Relay Battery terminal. This is the same lug to which the large red cable from the battery is normally connected.
- D. Connect ENGINE SECTION A wire #719 (pur) to the Starter Relay Start (S) terminal.
- E. Connect ENGINE SECTION A wire #720 (pnk) to one end of the Ballast Resistor. Connect the other end of the Ballast Resistor (or resistive wire) to the Ignition Coil POSITIVE (+) terminal with 14-gauge wire (you may have enough pink wire left over to accomplish this). If you are using a Ballast Resistor, mount it away from other wiring or hoses. The Ballast Resistor gets very hot during operation.
- F. A 14-gauge wire connected from the Starter Relay (I) terminal to the ignition coil side of the Ballast Resistor serves as a Ballast Resistor BYPASS during engine starting. If you are not using a Ballast Resistor (or resistive wire), this jumper is not necessary.

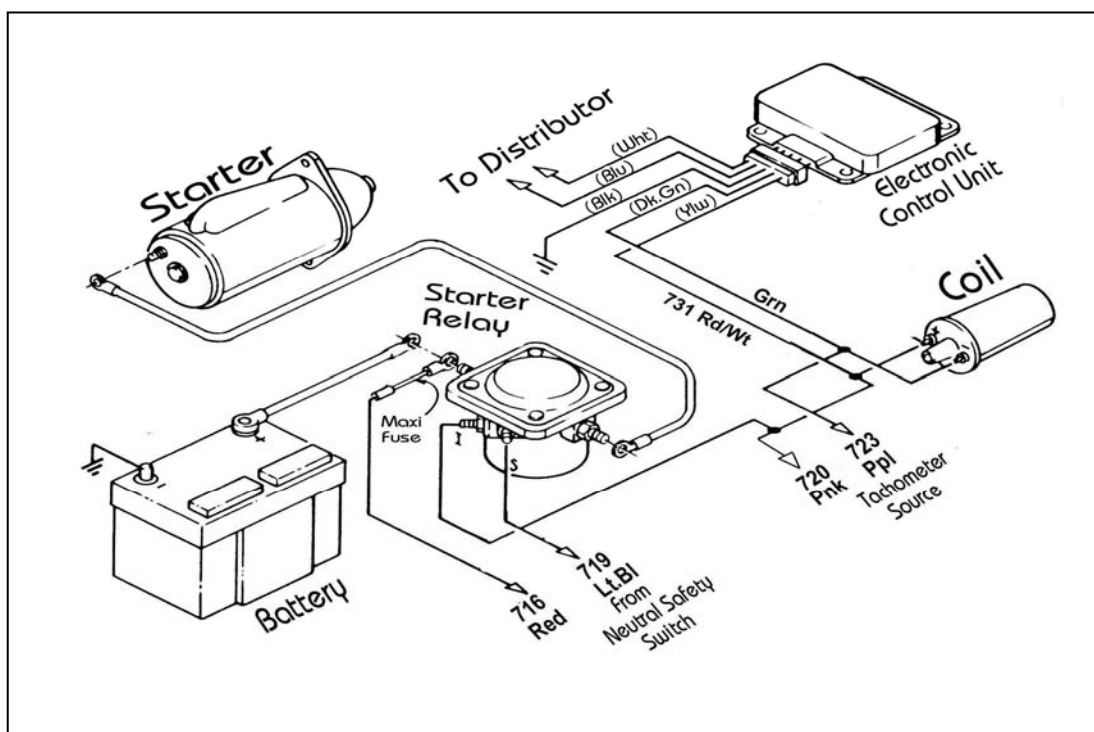

**Figure 8.7** Prestolite BID Ignition (Start/Run) System

- G. Connect ENGINE SECTION A wire #723 (pur/wht) to the Ignition Coil NEGATIVE (-) terminal. This is the tachometer source. If you are not using a tachometer, insulate and stow wire #723.

### 8.3 1978 and Newer

#### 8.3.1 Delco Charging System (1979 and Newer). Use Paragraph 8.2.2.

#### 8.3.2 Motorcraft Electronic Ignition System. See Figure 8.8.

*Note: If you are going to install an ammeter, see Section 7.3 first.*

- A. Locate the Electronic Ignition Module. It may not appear as represented. All wires connected to this unit MUST REMAIN CONNECTED IN THEIR ORIGINAL CONFIGURATION. You may replace them, one at a time, and incorporate them into the new harness, if you wish.
  1. The #720 red/wht wire attaches to the red wire in the 2-way connector of the module.
  2. The #719 lt.blu wire attaches to the wht wire in the 2-way connector of the module.
  3. The #782 grn wire attaches to the grn wire in the 4-way connector of the module.
- B. With crimping tool, attach Maxi-Fuse (**Figure 8.3**) onto end of ENGINE SECTION (single 10-gauge red wire #716) AFTER having routed wire from the Fuse Panel to the Starter Relay.
- C. Connect wire #716 – with Maxi-Fuse installed – to the Starter Relay Battery terminal. This is the same lug to which the large red cable from the battery is normally connected.
- D. Connect ENGINE SECTION A wire #719 (pur) to the Starter Relay Start (S) terminal.
- E. Connect ENGINE SECTION A wire #720 (pnk) to one end of the existing Resistive Wire. You may replace this wire with a Ballast Resistor. You Jeep may already have a Ballast Resistor installed. Connect the other end of the resistive wire (or Ballast Resistor) to the Ignition Coil POSITIVE (+) terminal with 14-gauge wire (you may have enough pink wire left over to accomplish this). If you are using a Ballast Resistor, mount it away from other wiring or hoses. It gets very hot during operation.
- F. A 14-gauge wire connected from the Starter Relay (I) terminal to the ignition coil side of the Ballast Resistor (or resistive wire) serves as a Ballast Resistor BYPASS during engine starting. If you are not using a Ballast Resistor (or resistive wire), this jumper is not necessary.
- G. Connect ENGINE SECTION A wire #723 (pur/wht) to the Ignition Coil NEGATIVE (-) terminal. This is the tachometer source. If you are not using a tachometer, insulate and stow wire #723.

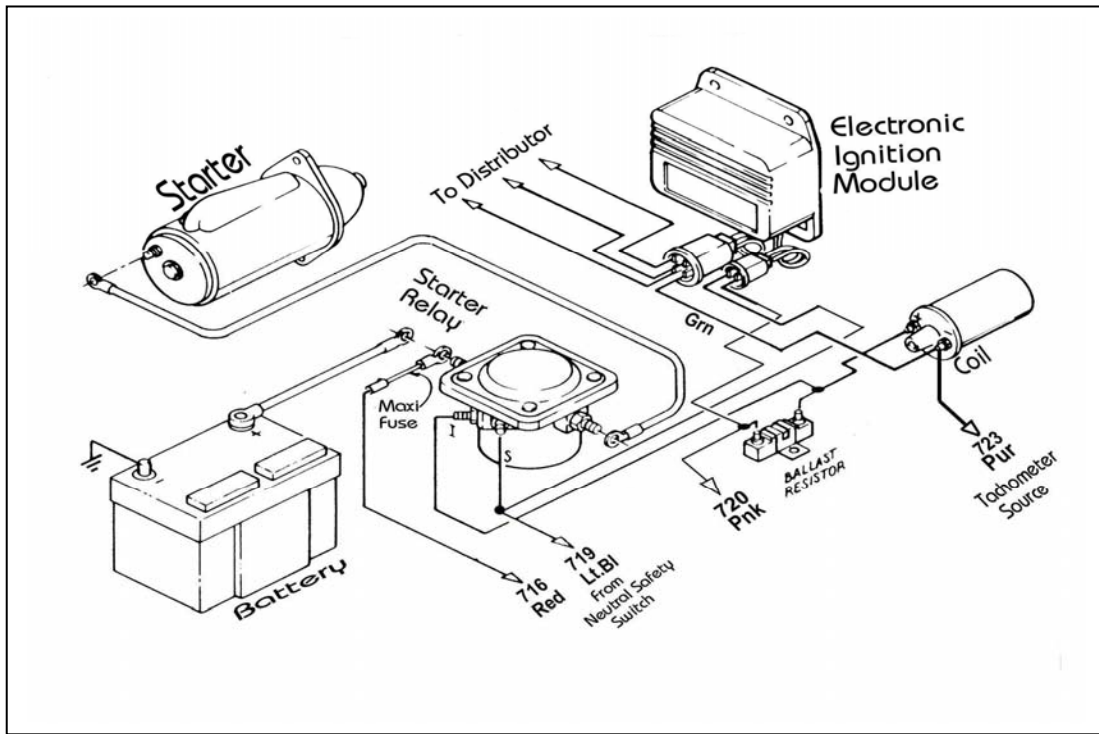

Figure 8.8 Motorcraft Electronic Ignition System

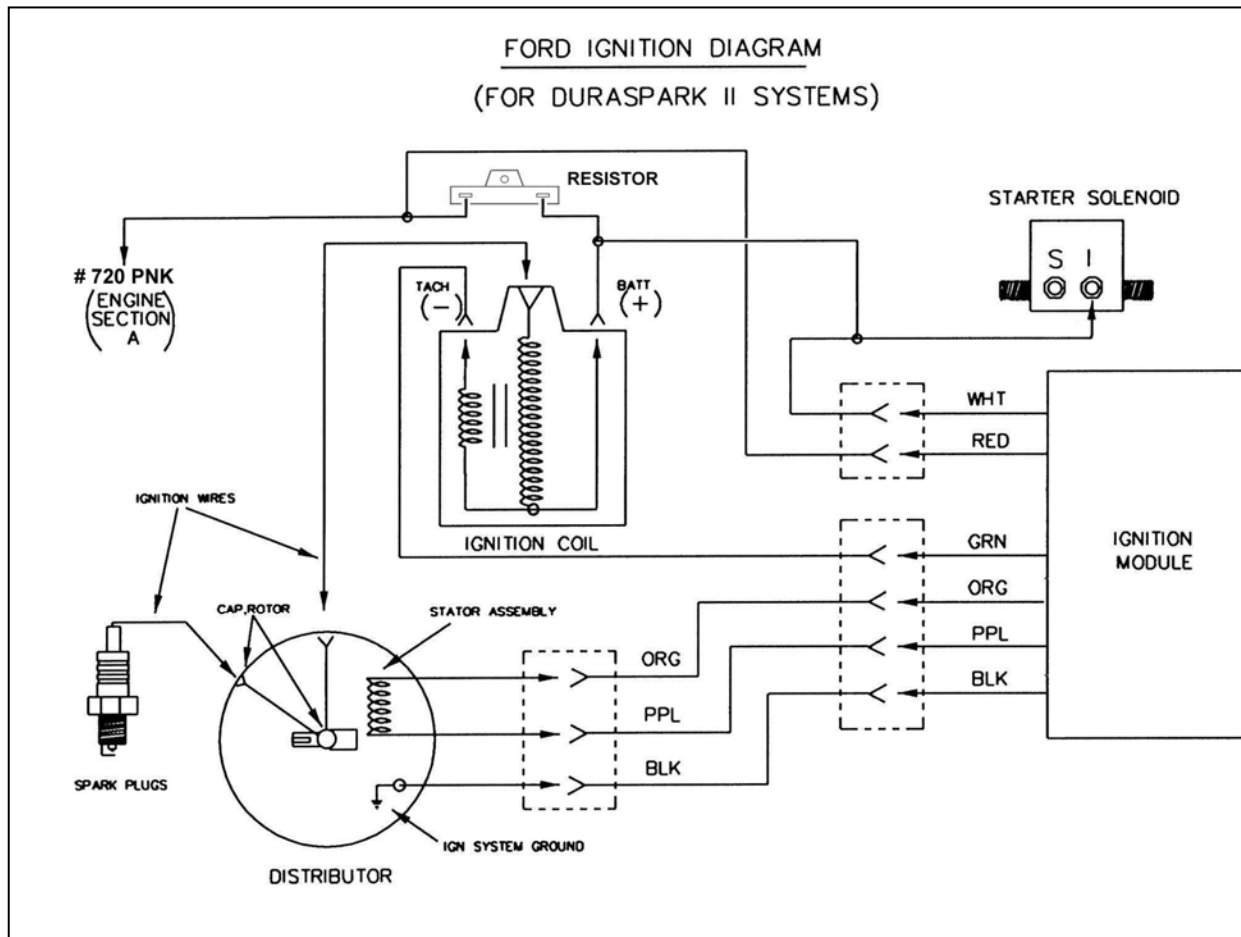

Figure 8.9 Ford Ignition Diagram (Duraspark II Systems)

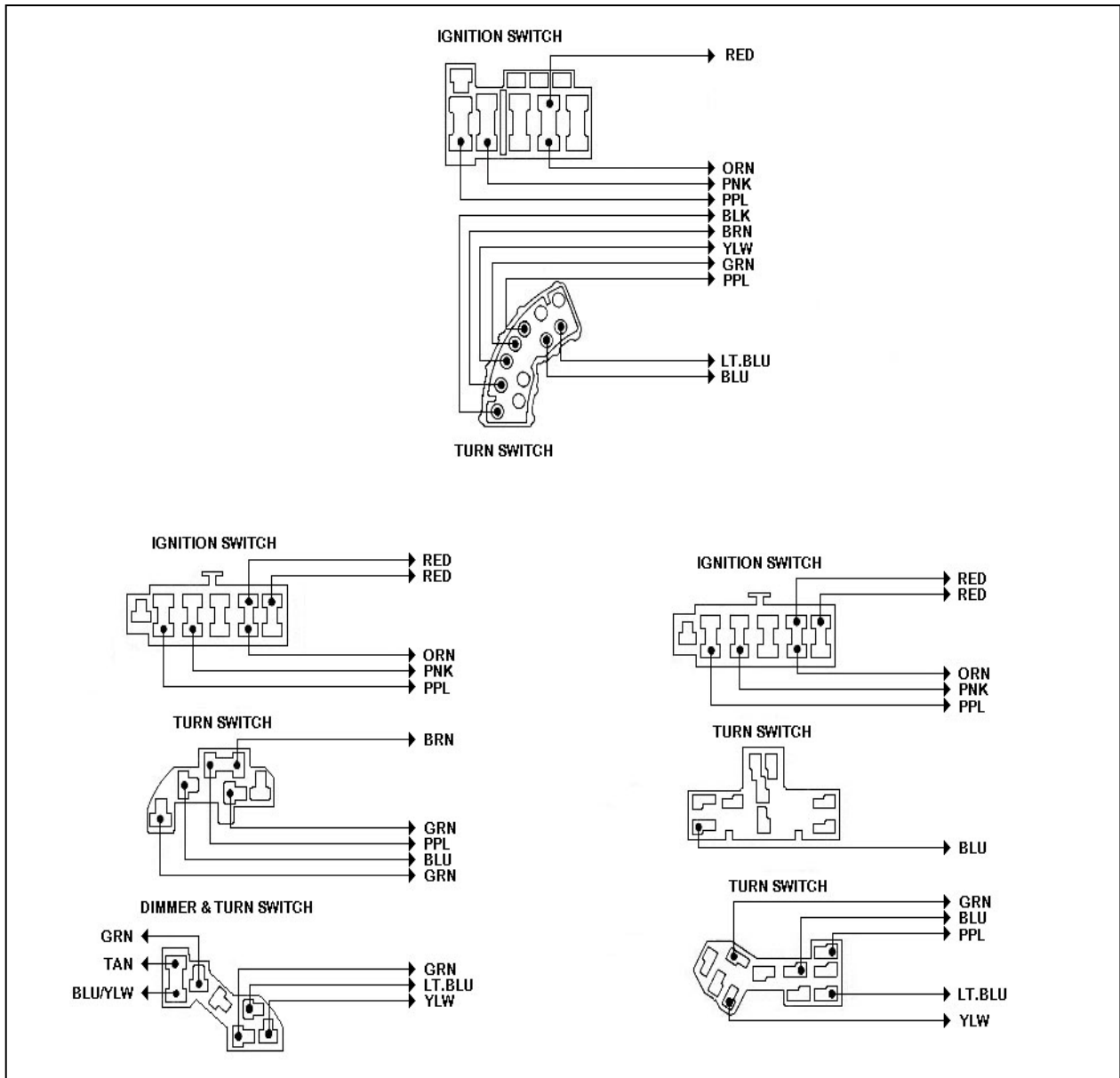

Figure 8.10 Ford Ignition Switch Connectors

## 9.0 CHARGING AND IGNITION SYSTEMS – JEEP WITH GM ENGINES INSTALLED

*Note: Your Alternator may not appear exactly as represented in the Figures. The circuits are wired the same way, though.*

### 9.1 Delco Alternator (before 1969) – External Regulator. See Figure 9.1.

- 9.1.1 With a short 16-gauge jumper wire, connect Voltage Regulator terminals 3 & 4 together. Connect ENGINE SECTION wire #714 (wht) to Voltage Regulator terminal 3 or 4.
- 9.1.2 Connect ENGINE SECTION wire #715 (red) to the Alternator Output lug (Bat).
- 9.1.3 Connect a 14-gauge wire from Voltage Regulator terminal 2 to Alternator terminal R. Connect a 14-gauge wire from Voltage Regulator terminal F to Alternator terminal F.

- 9.1.4 Connect a 16-gauge ground wire from the Alternator Ground lug (G) to chassis ground.

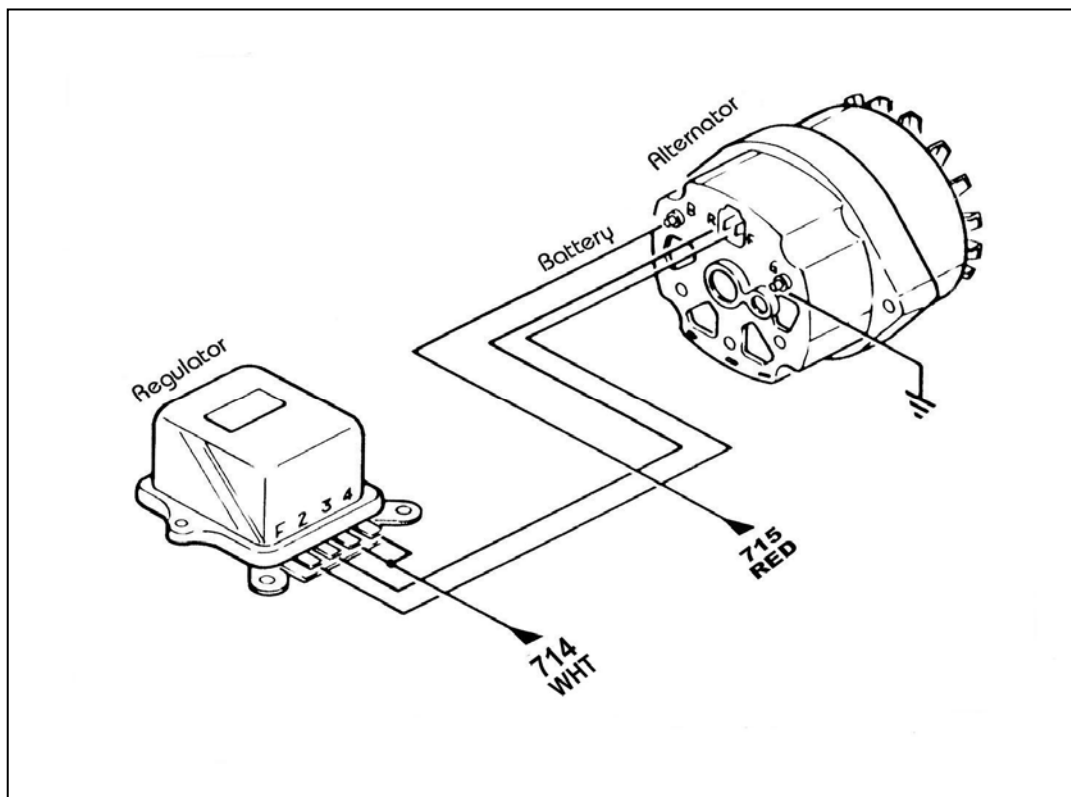

Figure 9.1 Delco Alternator (External Regulator)

- 9.2 Delco Alternator – Internal Regulator. Use Paragraph 8.2.2.
- 9.3 Delco One-Wire Alternator. Use Paragraph 8.2.3.
- 9.4 GM Ignition (Start/Run) System. Use Paragraph 8.1.4.

## 10.0 CHARGING AND IGNITION SYSTEMS – JEEPS WITH FORD ENGINES INSTALLED

- 10.1 Ford Alternator (2 configurations). Use Paragraph 8.2.1.
- 10.2 Ford Ignition (Start/Run) System. See Figure 10.1.

*Note: If you are going to install an ammeter, see Section 7.3 first.*

- 10.2.1 With crimping tool, attach Maxi-Fuse (**Figure 8.3**) onto end of ENGINE SECTION (single 10-gauge red wire #716) AFTER having routed wire (with or without ammeter) from the Fuse Panel to the Starter Relay. DO NOT OMIT IT!
- 10.2.2 Connect wire #716 – with Maxi-Fuse installed – to the Starter Relay Battery terminal. This is the same lug to which the large red cable from the battery is normally connected.
- 10.2.3 Connect ENGINE SECTION A wire #719 (pur) to the Starter Relay Start (S) terminal.

- 10.2.4 If you are using a Ballast Resistor, mount it away from other wiring and hoses. The Ballast Resistor gets very hot during operation. Connect ENGINE SECTION A wire #720 (pnk) to one end of the Ballast Resistor. Connect the other end of the Ballast Resistor to the Ignition Coil POSITIVE (+) terminal with 14-gauge wire (you may have enough pink left over to accomplish this). If you are not using a Ballast Resistor, connect wire #720 directly to the Ignition Coil POSITIVE (+) terminal.
- 10.2.5 The Ignition Coil NEGATIVE (-) terminal is connected to the Distributor. Also connect ENGINE SECTION A wire #723 (pur/wht) to the Ignition Coil NEGATIVE (-) terminal. This is the tachometer source. If you are not using a tachometer, insulate and stow wire #723.
- 10.2.6 Connect a 14-gauge wire from the Starter Relay Ignition (I) terminal to the ignition coil side of the Ballast Resistor. This wire serves as a Ballast Resistor BYPASS during engine starting. If you are not using a Ballast Resistor, leave the Starter Relay Ignition (I) terminal unconnected and do not connect the bypass wire.
- 10.2.7 Be sure the large red battery cable is connected from the other side of the Starter Relay to the Starter Motor.

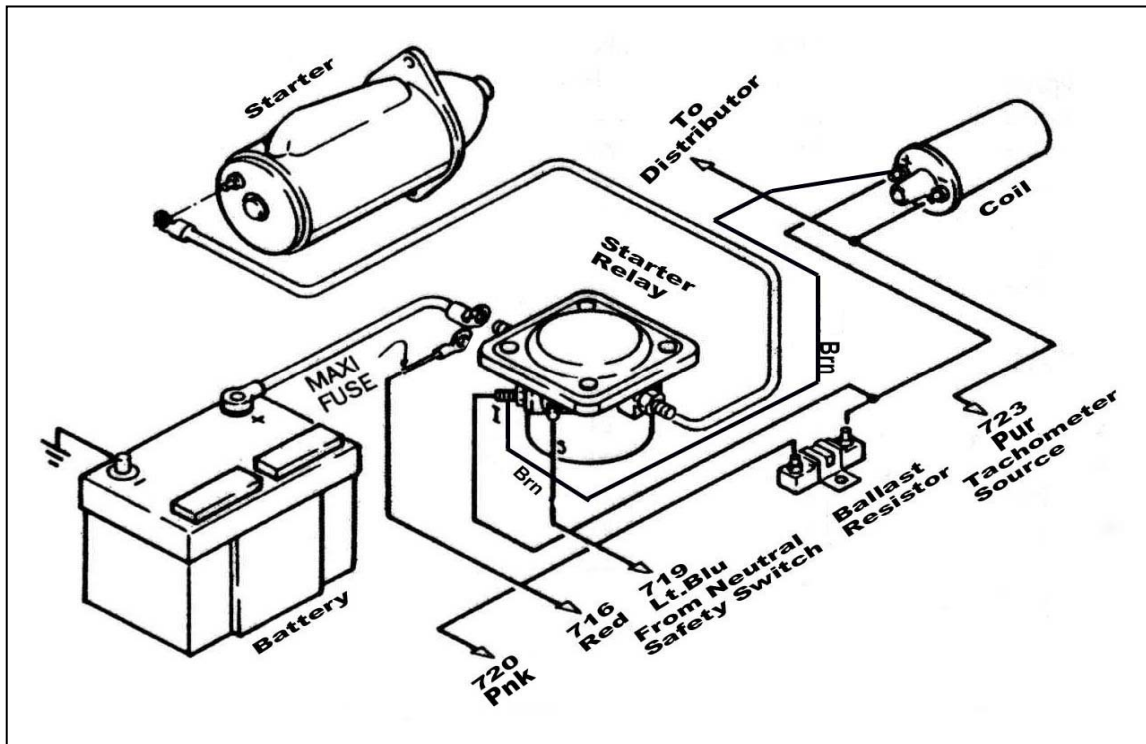
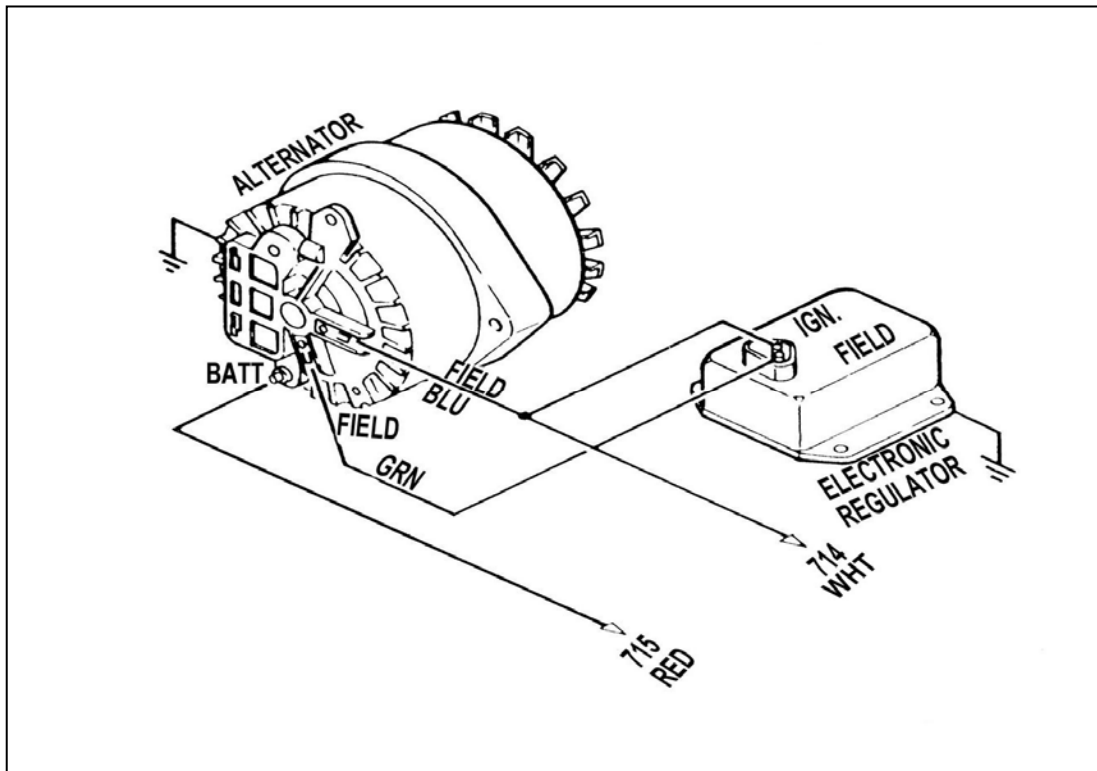

Figure 10.1 Ford Ignition (Start/Run) System

## 11.0 CHARGING AND IGNITION SYSTEMS – JEEPS WITH MOPAR ENGINES INSTALLED

11.1 Mopar Alternator. See Figure 11.1.

*Note: Your Alternator may not appear exactly as represented in Figure 11.1. The circuits are wired the same way, though.*



**Figure 11.1** Mopar Alternator

- 11.1.1** Mopar uses one of two kinds of voltage regulators: An electronic regulator and a mechanical one. The electronic voltage regulator is represented in **Figure 11.1**. It does not matter how the two terminals are connected, so long as they are BOTH connected. The mechanical regulator has terminals marked "F" (Field) and "I" (Ignition). In contrast to the electronic regulator, it DOES make a difference how these are connected.
- 11.1.2** Connect ENGINE SECTION A wire #714 (wht) to the Alternator Field (F) terminal as shown in **Figure 11.1**. Connect ENGINE SECTION A wire #715 (red) to the Alternator Output lug (Bat).
- 11.1.3** Connect a 14-gauge wire from the Alternator terminal where wire #714 is connected to either of the ELECTRONIC Voltage Regulator terminals OR terminal L of the MECHANICAL Voltage Regulator. On existing Mopar harnesses, this would be a blue wire.
- 11.1.4** Connect a 14-gauge wire from the other Alternator Field terminal (as shown in **Figure 11-1**) to the second terminal of the ELECTRONIC Voltage Regulator OR terminal F of the MECHANICAL Voltage Regulator. On existing Mopar harnesses, this would be a green wire. Also connect a 14-gauge wire from this terminal to chassis ground.
- 11.1.5** Finally, be sure BOTH the alternator and the voltage regulator are grounded.

**11.2 Mopar Ignition (Start/Run) System. See Figure 11.2.**

**Note:** If you are going to install an ammeter, see Section 7.3 first.

- 11.2.1 Connect ENGINE SECTION (single 10-gauge red wire #716) (with or without ammeter) to the Starter Relay Battery terminal. Retain excess wire.
- 11.2.2 With crimping tool, attach the Maxi-Fuse (Figure 8.3) onto remaining length of red 10-gauge wire. **DO NOT OMIT IT!** Connect this wire from the Starter Relay Battery terminal to the Starter Motor Battery terminal, as shown in Figure 11.2. **USE ONLY 10-GAUGE WIRE.**
- 11.2.3 Connect ENGINE SECTION A wire #719 (pur) to the Starter Relay Ignition (I) terminal.
- 11.2.4 Connect a 14-gauge wire from the Starter Relay Ground (G) terminal to the center terminal of the transmission mounted Neutral Safety Switch. Older Mopar neutral safety switches have only one terminal. On newer switches, the two outside terminals are for backup lights. Use existing wiring to connect these two terminals as shown in Figure 11.2.
  - A. Mopar style 3 terminal switch; red #758 is ignition power, blk #783 is relay ground and wht/blk #756 is backup lights output.
  - B. All other style switches; red #758 and wht/blk #756 wires attach to the backup light switch. The blk #783 wire will not be used.

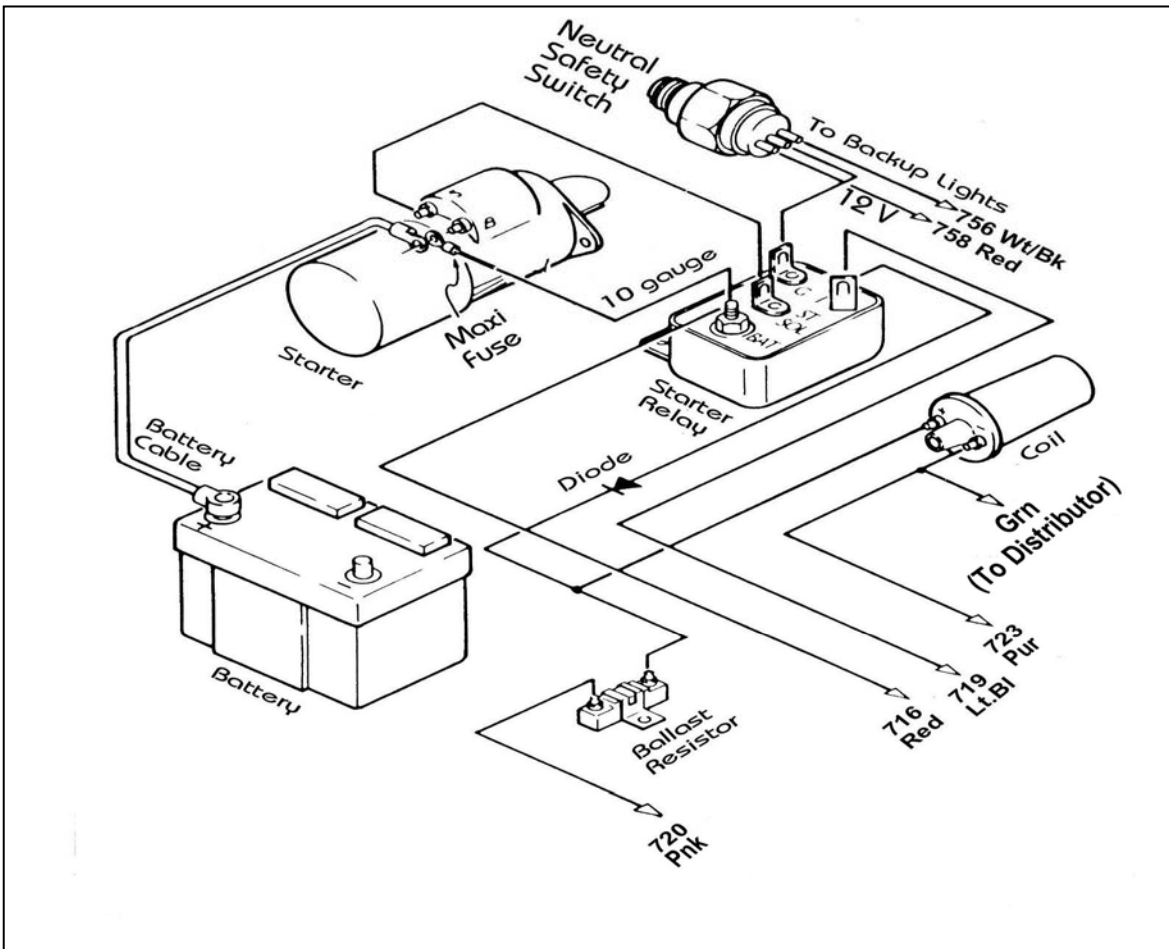

Figure 11.2 Mopar Ignition (Start/Run) System



- 11.2.5 If the Neutral Safety Switch is mounted in the floor shifter, connect the Starter Relay Ground (G) terminal to chassis ground.
  
- 11.2.6 If you are using a Ballast Resistor, mount it away from other wiring and hoses. The Ballast Resistor gets very hot during operation. Connect ENGINE SECTION A wire #720 (pnk) to one end of the Ballast Resistor. Connect the other end of the Ballast Resistor to the Ignition Coil POSITIVE (+) terminal with 14-gauge wire (you may have enough pink wire left over to accomplish this). If you are not using a Ballast Resistor, connect wire #720 directly to the Ignition Coil POSITIVE (+) terminal.
  
- 11.2.7 Connect a 14-gauge wire from the Starter Relay Ignition (I) terminal to the ignition coil side of the Ballast Resistor. This wire serves as a Ballast Resistor BYPASS during engine starting. You must add a diode (8-amp min., 100 PIV) to this wire as shown in **Figure 11.2**. If you are not using a Ballast Resistor, do not connect this wire.
  
- 11.2.8 The Ignition Coil NEGATIVE (-) terminal is connected to the Distributor. Also connect ENGINE SECTION A wire #723 (pur/wht) to the Ignition Coil NEGATIVE (-) terminal. This is the tachometer source. If you are not using a tachometer, insulate and stow wire #723.
  
- 11.2.9 Be sure the large red battery cable is connected from the Battery to the Starter Motor Battery terminal (the same place the Maxi-Fuse is connected).

## 12.0 WIRE CONNECTION INDEX AND FUSE REQUIREMENTS

### 12.1 Wire Connection Index

In each section, connect the wire, as identified by its wire color, to the appropriate item in the CONNECT TO column. Pay close attention to the **Notes** in this section, as identified by a small, raised number such as the one at the end of this sentence. The term "B+" means "Battery Positive" or Battery Power.

**Table 12.1** is divided into sections that correspond to the sections of your wire harness, (ACCESSORY SECTION B+, DIMMER SWITCH SECTION, etc.). The index is divided vertically into six columns: COLOR, GA., NO., CONNECT TO, ORIGIN, and SECTION OF ORIGIN.

The columns labeled ORIGIN and SECTION OF ORIGIN are for your reference ONLY. The items in these columns tell you where each wire originates (ORIGIN) and from which section (SECTION OF ORIGIN) of the harness.

The column labeled NO. contains a 700 series number that is used to identify various wires in the wiring diagrams that are a part of these instructions. These numbers are physically marked on the wires themselves.

Many (but not all) of the wire numbers occur TWICE in this index. That is because you will be connecting BOTH ENDS of many of the particular wire segments. However, some wire segments are pre-connected at one end. For instance, all wires originating from the fuse panel and certain other wires such as those originating from the horn relay, the dimmer switch, and the instrument panel section. These pre-constructed wires are identified by an asterisk (\*) in the ORIGIN column.

Color	Ga	No.	Connect to	Origin	Section of Origin
			<b>ACCESSORY SECTION SWITCHES</b>		
Gry/Wht	18	701	Cooling Fan Switch	Fan Relay	Headlight Section A
Blk/Wht	14	702	A/C – Heat Switch	A/C Compressor	Engine Section A
			<b>ACCESSORY SECTION B+</b>		
Tan(1)	14	703	Cigarette Lighter B+	Fuse Panel*	Fuse Panel
Blk/Wht	14	704	A/C – Heat Switch B+	Fuse Panel*	Fuse Panel
Blu	16	705	Wiper Switch B+	Fuse Panel*	Fuse Panel
Gry/Wht	18	706	Cooling Fan Switch B+	Fuse Panel*	Fuse Panel
Wht/Red	18	759	Clock	Fuse Panel*	Fuse Panel
Orn/Blk	18	770	4 Wheel Drive Switch	Fuse Panel*	Fuse Panel
Org/Wht	16	799	Acc. #1 Power (Ign. B+)	Fuse Panel*	Fuse Panel
Org	16	798	Acc. #2 Power (Ign. B+)	Fuse Panel*	Fuse Panel
Red/Ylw	16	795	Acc. #3 Power (B+)	Fuse Panel*	Fuse Panel
Red/Wht	16	796	Acc. #4 Power (B+)	Fuse Panel*	Fuse Panel
Red/Blu	16	797	Acc. #5 Power (B+)	Fuse Panel*	Fuse Panel
			<b>DIMMER SWITCH SECTION</b>		
Blu/Ylw(2)	14	707	Dimmer Switch	Headlight Switch	Headlight Section B
Lt.Grn	14	708	Dimmer Switch	High Beam	Headlight Section A
Tan	14	709	Dimmer Switch	Low Beam	Headlight Section A
			<b>ENGINE SECTION</b>		
Wht	14	714	Alternator Exciter	Fuse Panel*	Fuse Panel
Red	12	715	Alternator B+	Fuse Panel*	Fuse Panel
Tan	18	760	Brake Pressure Switch (master cylinder)	Emergency Brake Indicator	Instrument Panel Section
Orn	18	763	Hood Light	Fuse Panel*	Fuse Panel
			<b>ENGINE SECTION (SINGLE WIRE)</b>		
Red(3)	10	716	Battery @ St.Solenoid B+	Fuse Panel*	Fuse Panel
			<b>EMERGENCY BRAKE SECTION (SINGLE WIRE)</b>		
Tan	18	762	Emergency Brake Switch	Inst. Panel Section	
			<b>BRAKE SWITCH SECTION</b>		
Orn(4)	16	717	Brake Switch B+	Fuse Panel*	Fuse Panel
Wht	16	718	Brake Switch	Turn Signal Switch	Turn Signal Section
			<b>BACKUP SECTION</b>		
Lt.Grn(1)	18	758	Backup Switch	Fuse Panel*	Fuse Panel
Lt.Grn(1)	18	756	Backup Switch	Backup Lights	Tail Section

Table 12.1 Wire Connection Index, 1 of 3

Color	Ga	No.	Connect to	Origin	Section of Origin
			<b>ENGINE SECTION A</b>		
Pur	12	719	Start Solenoid (S Term.)	Ign. Switch Start	Ign. Switch Section
Pnk	14	720	Coil B+	Fuse Panel*	Fuse Panel
Lt.Grn	18	721	Temperature Sending Unit	Temp. Gauge	Inst. Panel Section
Lt.Blu/Blk	18	722	Oil Pressure Sending Unit	Oil Pressure Gauge	Inst. Panel Section
Pur/Wht	18	723	Tachometer Source	Tachometer	Inst. Panel Section
Blk/Wht	14	702	A/C Compressor	A/C Thermostat Sw.	Accy.Section Switches
Red	18	754	Electric Choke	Fuse Panel*	Fuse Panel
Blk	18	771	4 Wheel Drive Switch	4WD Indicator	Inst. Panel Section
			<b>HEADLIGHT SECTION A</b>		
Grn	14	724	Horn B+	Horn Relay*	Fuse Panel
Blu	18	725	Right Front Turn Signal	Turn Signal Switch	Turn Signal Section
Lt.Blu	18	726	Left Front Turn Signal	Turn Signal Switch	Turn Signal Section
Brn	18	727	Park Lights	Headlight Switch	Headlight Section B
Lt.Grn	14	708	High Beam	Dimmer Switch	Dimmer Sw. Section
Tan	14	709	Low Beam	Dimmer Switch	Dimmer Sw. Section
Gry/Wht	18	701	Cooling Fan Relay	Fan Switch	Accy. Section Switches
			<b>HEADLIGHT SECTION B</b>		
Red/Blk(7)	12	728	Headlight Switch B+	Fuse Panel*	Fuse Panel
Blu/Ylw	14	707	Headlight Switch	Dimmer Switch	Dimmer Sw. Section
Brn	14	729	Headlight Switch	Tail Lights	Tail Section
Brn	18	727	Headlight Switch	Park Lights	Headlight Section A
Brn(6)	18	730	Headlight Switch	Instr. Panel Lighting	Instr. Panel Section
			<b>IGNITION SWITCH SECTION</b>		
Orn	12	733	Ignition Switch Ignition	Fuse Panel*	Fuse Panel
Red	12	734	Ignition Switch B+	Fuse Panel*	Fuse Panel
Pur(5)	12	719	Ignition Switch Start	Starter Solenoid	Engine Section A
			<b>INSTRUMENT PANEL SECTION</b>		
Red/Wht	18	735	Voltmeter Source & Gauges B+	Fuse Panel*	Fuse Panel
Grn	18	736	High Beam Indicator	Dimmer Switch*	Dimmer Sw. Section
Lt.Blu	18	737	Left Turn Indicator	Lf.Front Turn Signal*	Turn Signal Section
Blu	18	738	Right Turn Indicator	Rt.Front Turn Signal*	Turn Signal Section
Brn	18	730	Instr. Panel Lighting	Headlight Switch	Headlight Section B
Pnk	18	739	Fuel Gauge	Fuel Sending Unit	Tail Section
Lt.Grn	18	721	Temperature Gauge	Temp. Sending Unit	Engine Section A
Lt.Blu/Blk	18	722	Oil Pressure Gauge	Oil Pres. Sending Unit	Engine Section A
Pur/Wht	18	723	Tachometer	Tachometer Source	Engine Section A
Tan	18	760	Emergency Brake Indicator	Emer. Brake Switch	Engine Section
Tan	18	761	Emer. Brake Indicator B+	Fuse Panel*	Fuse Panel
Blk	18	771	4WD Indicator	4WD Switch	Engine Section A

Table 12.1 Wire Connection Index, 2 of 3

Color	Ga.	No.	Connect to	Origin	Section of Origin
			<b>TURN SIGNAL SECTION</b>		
Brn	14	751	Emer. Flasher Switch B+	Emer. Flasher Relay*	Fuse Panel
Pur	14	752	Turn Signal Sw.Flasher B+	Turn Flasher Relay*	Fuse Panel
Blk	18	753	Horn Switch	Horn Relay*	Fuse Panel
Grn	14	748	Turn Signal Switch	Rt.Rear Turn Signal	Tail Section
Ylw	14	749	Turn Signal Switch	Lt.Rear Turn Signal	Tail Section
Blu	18	725	Turn Signal Switch	Rt.Front Turn Signal	Headlight Section A
Wht	16	718	Turn Signal Switch	Brake Switch	Engine Section A
Lt.Blu	18	726	Turn Signal Switch	Lt.Front Turn Signal	Headlight Section A
			<b>RADIO SECTION</b>		
Red/Blk	18	741	Radio B+ Switched	Fuse Panel*	Fuse Panel
Red	18	740	Radio B+	Fuse Panel*	Fuse Panel
			<b>TAIL SECTION</b>		
Wht	18	745	Dome Lights B+	Fuse Panel*	Fuse Panel
Grn	14	748	Rt.Rear Turn Signal	Turn Signal Switch	Turn Signal Section
Ylw	14	749	Lt.Rear Turn Signal	Turn Signal Switch	Turn Signal Section
Pnk	18	739	Fuel Sending Unit	Fuel Gauge	Instr. Panel Section
Brn	14	729	Tail Lights	Headlight Switch	Headlight Section B
Orn	18	750	Third Brake Light	Turn Signal Switch*	Turn Signal Section
Lt.Grn(1)	18	756	Backup Lights	Backup Switch	Cruise Control Section

**Table 12.1** Wire Connection Index, 3 of 3

**Notes:**

1. Depending upon the particular wire harness you purchased, you may not have some of these wires.
2. 2-color wires: 2<sup>nd</sup> color (stripe) may not be intense color. Observe 2-color wires closely.
3. This section consists of only one large (10-gauge) wire.
4. From fuse panel to brake switch.
5. This wire is cut and spade lugs have been installed so that your existing neutral safety switch circuit can be wired into your harness. The neutral safety switch is located at the base of Jeep steering columns and in Mopar transmissions. Do not attempt to defeat your automobile's neutral safety switch. If your Jeep does not have a neutral safety switch, please install one.
6. This is a short length of wire that is not connected on either end.
7. This wire is power for the portion of the headlight switch that goes out to the headlights and front parking lights.
8. This wire is power for the portion of the headlight switch that goes out to the instrument panel lights and the taillights. This wire will not be used if your headlight switch has only one power terminal.

## 12.2 Fuse Requirements

HORN □ 20 □ F11	F1	COIL □ 20 □
BRAKE □ 20 □ F12	F2	TURN □ 15 □
HAZARD □ 20 □ F13	F3	WIPERS □ 15 □
HEADLIGHT □ 30 □ F14	F4	A/C-HEAT □ 30 □
DOME □ 15 □ F15	F5	CHOKER/ACC □ 20 □
RADIO(B+) □ 10 □ F16	F6	GAUGES □ 15 □
CIG. LIGHTER □ 20 □ F17	F7	ELEC. FAN □ 5 □
ACC. #3 □ 15 □ F18	F8	4X4/ACC. □ 15 □
ACC. #4 □ 15 □ F19	F9	RADIO (S/U) □ 15 □
ACC. #5 □ 15 □ F20	F10	ACC. #2 □ 15 □

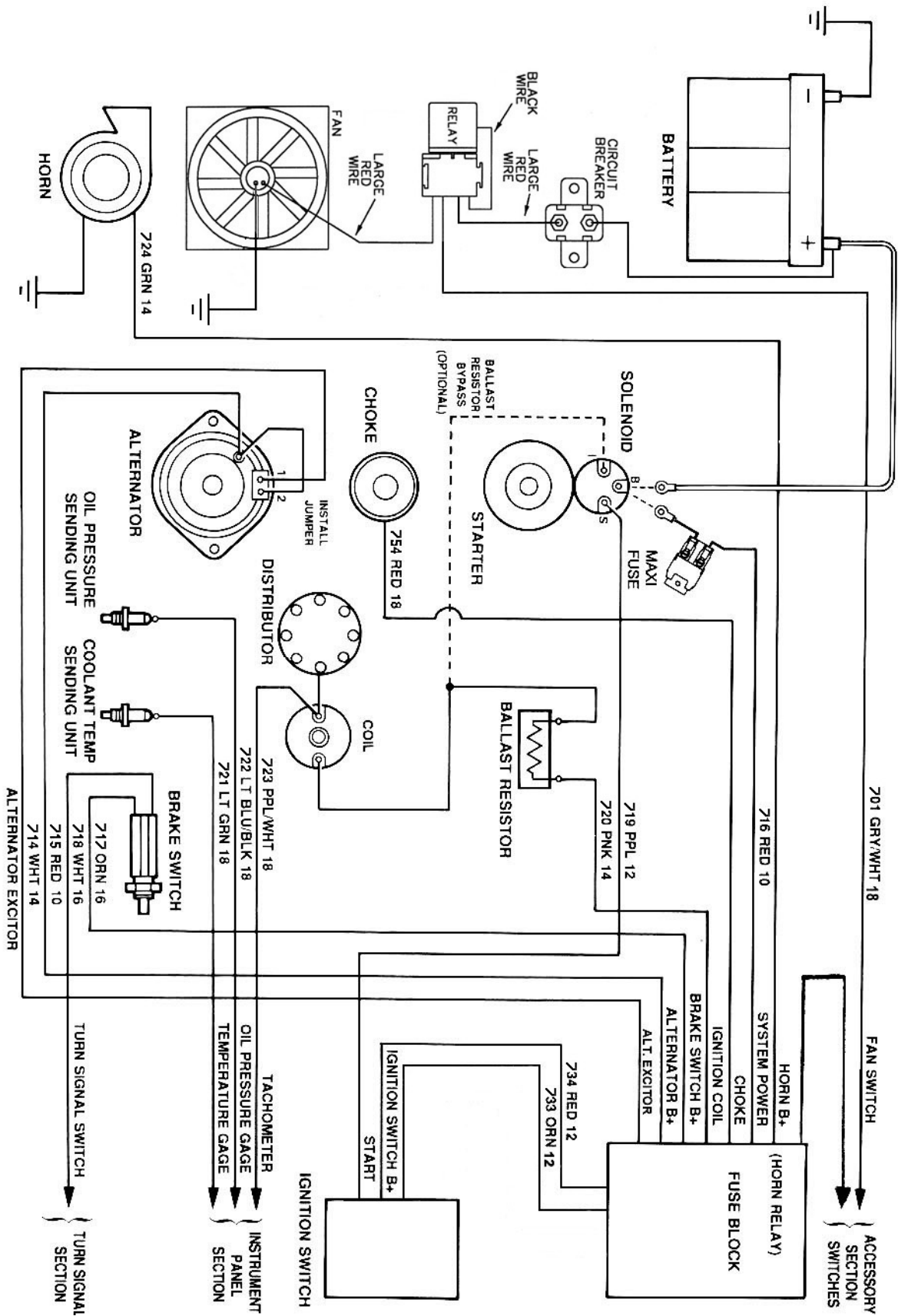

# ENGINE WIRING

Diagram 1 Engine Wiring Diagram

# INSTRUMENT PANEL SECTION WIRING

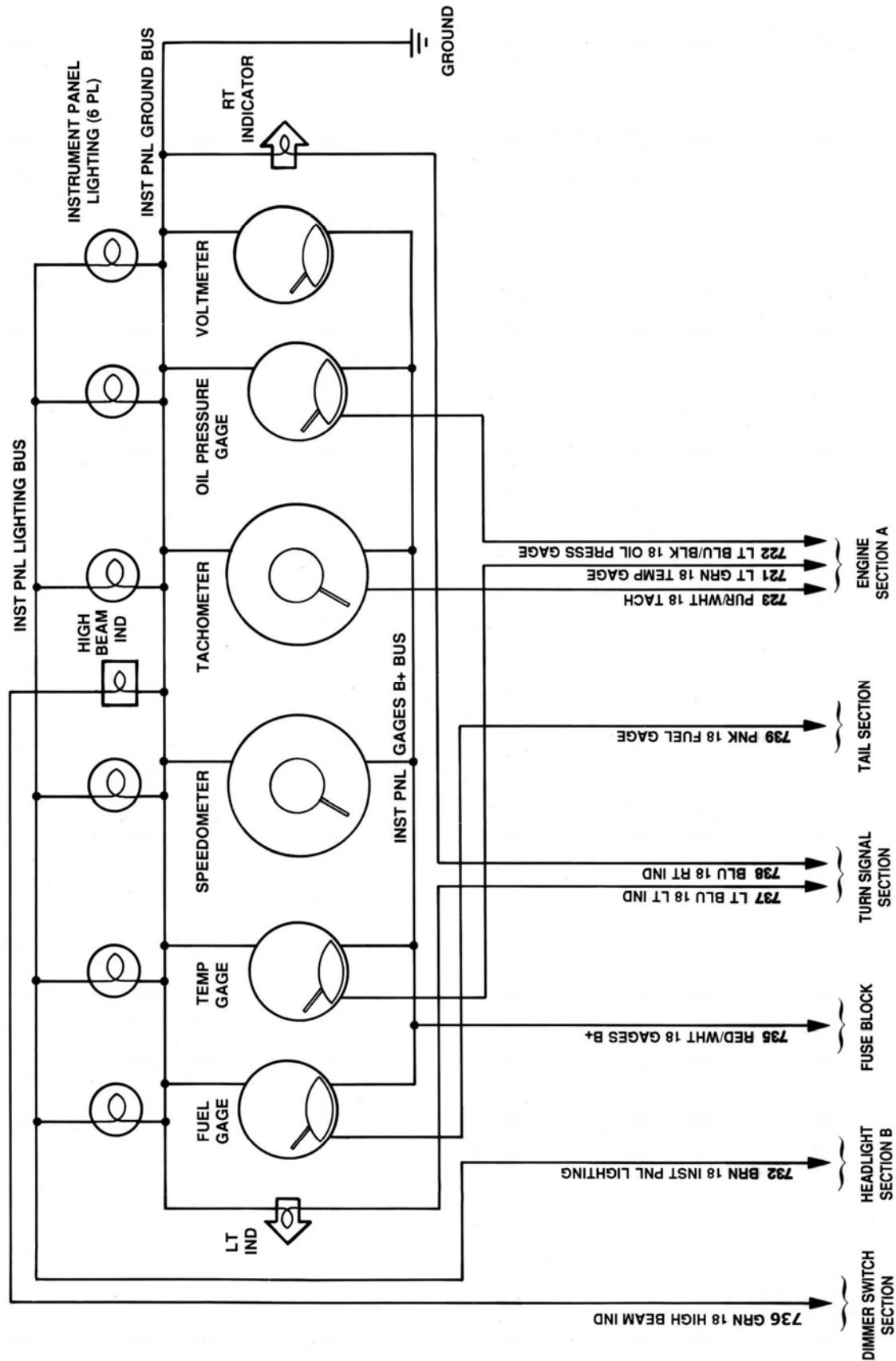
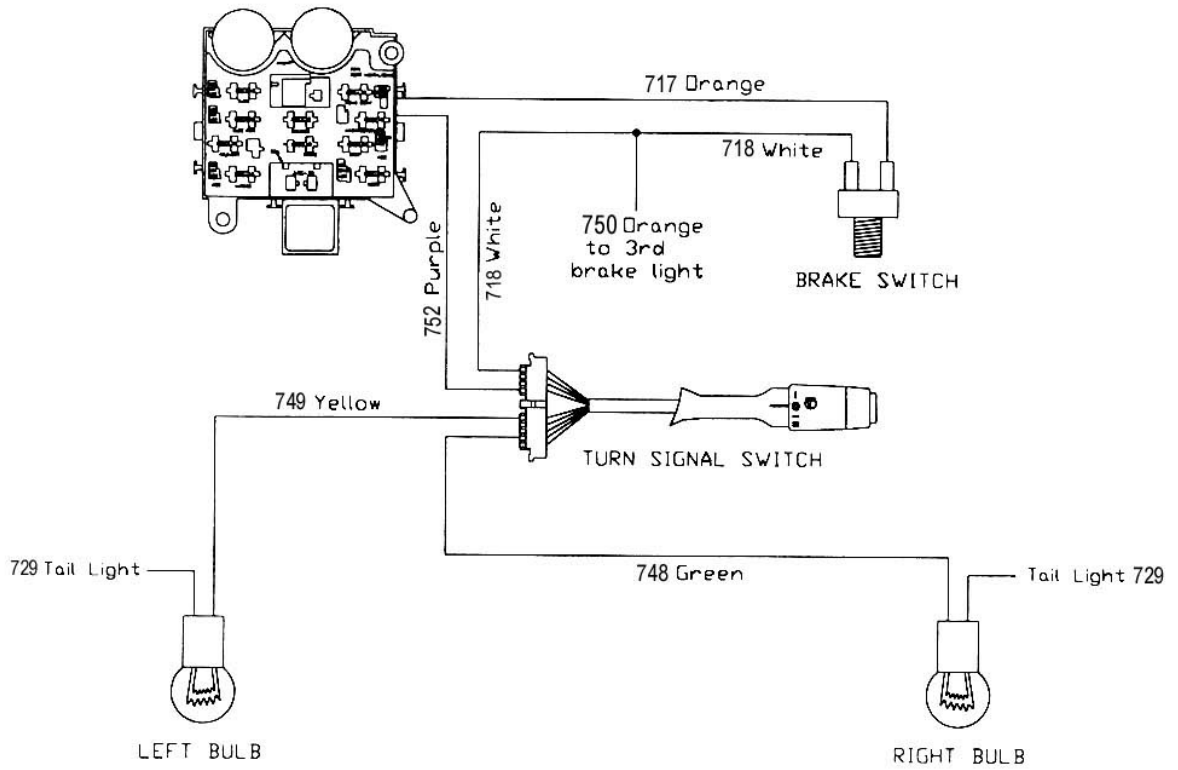

Diagram 2 Instrument Panel Section Wiring Diagram

# INTEGRATED BRAKE LIGHTS



# SEPARATE TURN/ BRAKE LIGHTS

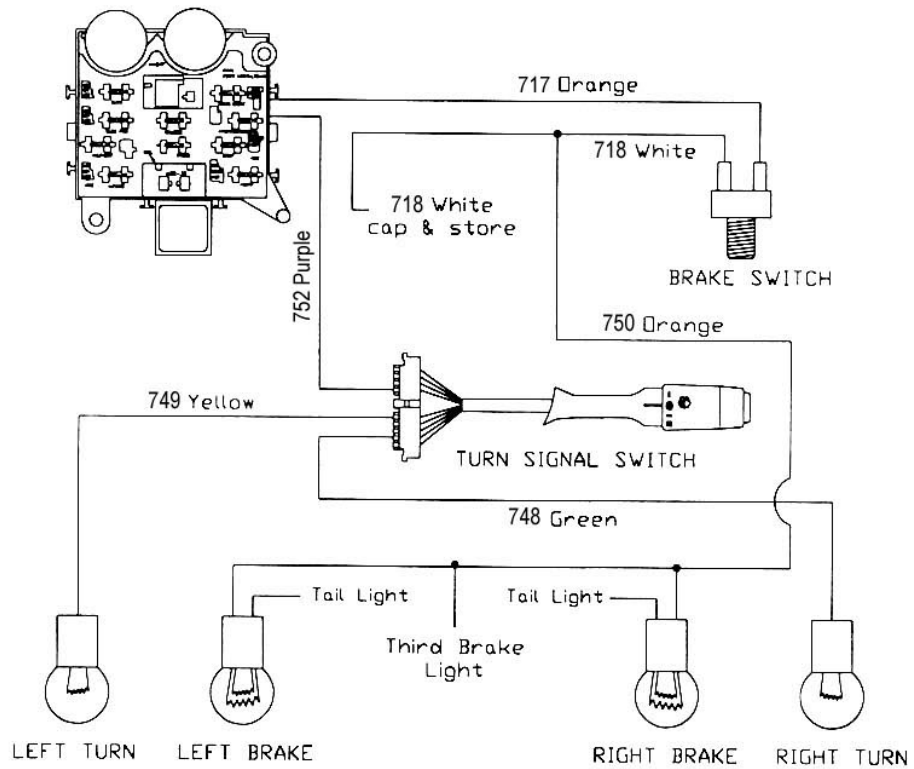

Diagram 3 Integrated Brake Lights & Separate Turn/Brake Lights



## **Painless Performance Limited Warranty and Return Policy**

Chassis harnesses and fuel injection harnesses are covered under a lifetime warranty. All other products manufactured and/or sold by Painless Performance are warranted to the original purchaser to be free from defects in material and workmanship under normal use. Painless Performance will repair or replace defective products without charge during the first 12 months from the purchase date. No products will be considered for warranty without a copy of the purchase receipt showing the sellers name, address and date of purchase. You must return the product to the dealer you purchased it from to initiate warranty procedures.