

# Quadratec® Aluminum Rear Bumper

Installation Manual for '18 - Current Wrangler JL Vehicles  
#12057.0262

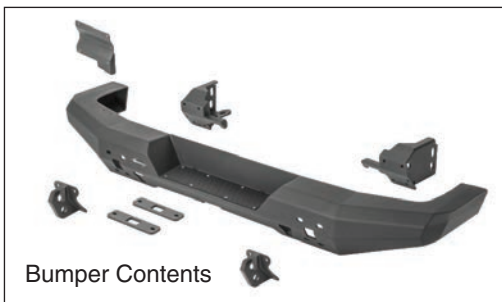

## **⚠ WARNING ⚠**

**TO REDUCE RISK OF SERIOUS INJURY OR PROPERTY DAMAGE: READ ALL SAFETY MESSAGES AND UNDERSTAND ALL INSTRUCTIONS AND PROCEDURE *NOTICES* BEFORE ATTEMPTING TO INSTALL OR USE THIS PRODUCT.**

## **⚠ CAUTION ⚠**

**RISK OF EYE INJURY! SAFETY GLASSES MUST BE WORN AT ALL TIMES WHILE INSTALLING OR MAINTAINING THIS PRODUCT. TORQUE AND RECHECK FASTENERS AFTER 250 MILES AND FREQUENTLY THEREAFTER. INSPECT BUMPER, WINCH AND MOUNT BEFORE USE. DO NOT USE IF DAMAGED.**

## **NOTICE**

**CHECK STATE AND LOCAL HIGHWAY SAFETY LAWS REGARDING PERMITTED BUMPER TYPES AND HEIGHTS.**

**A Few Words About Product Safety:**

Your Quadratec® Aluminum Rear Bumper is intended to enhance the utility and enjoyment of your off road capable vehicle. Before installation, please review the following safety information and installation recommendations.

Throughout these instructions important safety information is generally preceded by one of three signal words indicating the relative risk of injury, property damage or adverse consequence. **The signal words mean:**

**⚠ WARNING ⚠**

a hazardous situation which, if not avoided, could result in death or serious injury. You **CAN** be **KILLED** or **SERIOUSLY HURT** if you don't follow instructions.

**⚠ CAUTION ⚠**

a hazardous situation which, if not avoided, could result in minor or moderate injury. You **CAN** be moderately **HURT** and also may suffer property damage if you don't follow instructions.

**NOTICE**

Careful attention is required to this instruction or operation but does generally not relate to personal injury. Damage to your Quadratec® product or other property may result if you don't follow instructions.

**Before You Begin Installation:**

Congratulations on your purchase of Quadratec® Aluminum Rear Bumper for your Jeep® Wrangler. This custom fit front Bumper has been designed for long life and a great look. Though constructed of only the finest materials, this bumper must be maintained to keep its look while performing under the toughest conditions. Please see page 10

for important care & maintenance tips to keep your bumper looking like new. When unpacking, check to make sure all parts are included and not damaged due to shipping. If any part is missing or broken, please call Customer Service at 800-745-6037 as soon as possible. Thank you again for your purchase and let's start the installation process.

**NOTICE**

**AS YOU UNPACK YOUR BUMPER, BE CAREFUL NOT TO SCRATCH THE FINISH WITH A KNIFE OR RAZOR. WE SUGGEST PLACING THE UNPACKED BUMPER BACK INTO THE ORIGINAL BOX SO IT DOES NOT GET SCRATCHED BEFORE THE INSTALLATION BEGINS.**

**⚠ CAUTION ⚠**

**WELDED REAR BUMPERS ARE HEAVY AND WE STRONGLY SUGGEST THE ASSISTANCE OF AN ABLE-BODIED ASSISTANT DURING LIFTING AND INSTALLATION OF YOUR BUMPER.**

**⚠ CAUTION ⚠**

**READ ALL SAFETY MESSAGES AND ALWAYS WEAR SAFETY GLASSES WHEN WORKING WITH TOOLS.**

**Quadratec Aluminum Rear Bumper Parts & Hardware:**

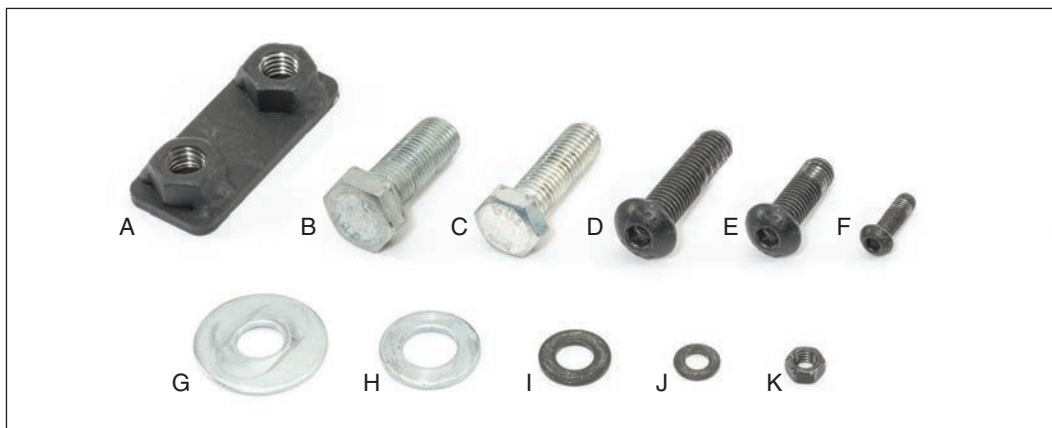
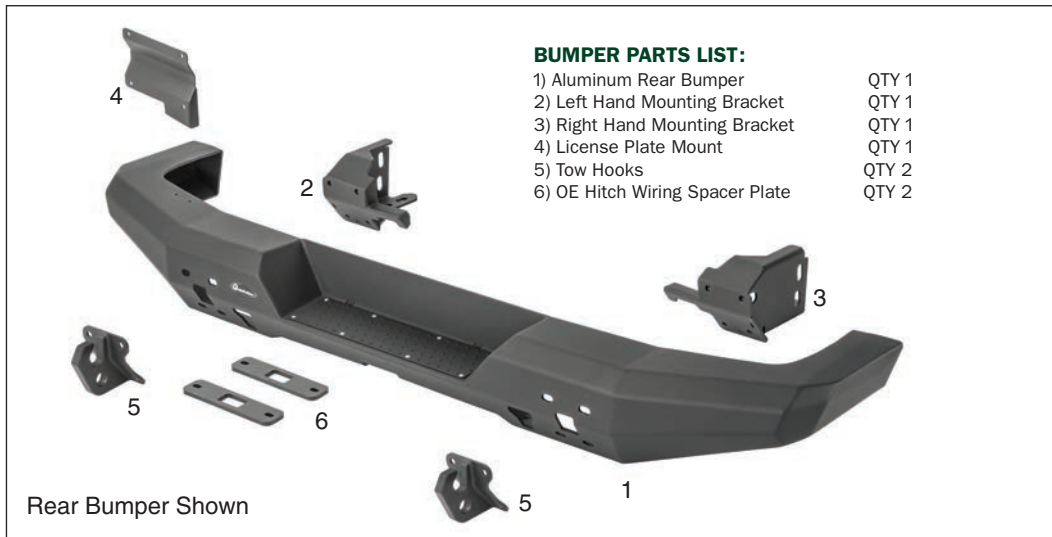

**HARDWARE LIST: Packet 12057.9262**

- |                                      |        |
|--------------------------------------|--------|
| A.) Nut Plate                        | QTY 1  |
| B.) M14 x 35 Hex Bolts               | QTY 6  |
| C.) M12 x 40 Hex Bolts               | QTY 2  |
| D.) M10 x 50 Button Head Allen Bolts | QTY 2  |
| E.) M10 x 30 Button Head Allen Bolts | QTY 8  |
| F.) M6 x 20 Button Head Allen Bolts  | QTY 6  |
| G.) 12mm Fender Washers              | QTY 2  |
| H.) 14mm Flat Washers                | QTY 6  |
| I.) 10mm Flat Washers                | QTY 8  |
| J.) 6mm Flat Washers                 | QTY 12 |
| K.) 6mm Nylock Nuts                  | QTY 6  |

**REQUIRED TOOLS:**

- Safety Glasses
- 16, 19, 21 & 22mm Sockets
- Extension & Ratchet
- 8mm Sockets & Ratchet
- 10mm Box End Wrench
- 4mm Allen Hex Key Wrench
- Flat Blade Screwdrivers
- Forked Clip/Trim Removal Tool
- Torque Wrench (ft lbs)

### Aluminum JL Rear Bumper Installation Prep:



Put on safety glasses. Start by removing the factory splash guard. Remove the 6 screws holding the inner shields on, 3 on either side, using a 8mm socket. (FIG 1)

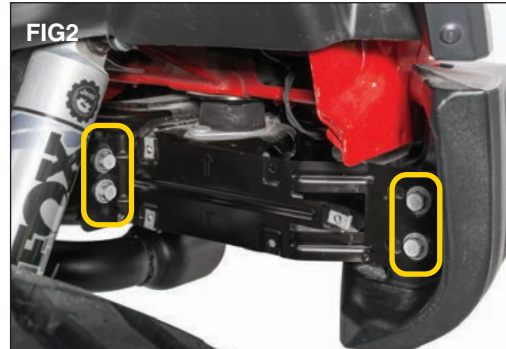

Remove the 8 bolts holding the support brackets on, 4 on either side, using a 16mm socket. (FIG 2)



Disconnect the rear bumper harness by sliding the gray locking tab backwards and depressing the black tab. (FIG 3)

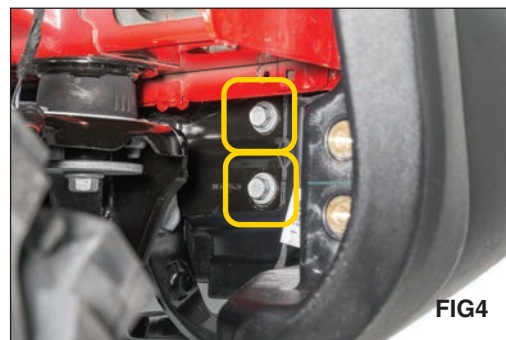

Remove the 4 bumper bolts, 2 on either side, using a 16mm socket. (FIG 4)  
Remove stock bumper and set aside.



Remove the original tow hook if equipped using a 21mm socket. (FIG 5)  
Remove bumper bracket as well.  
There are 4 bolts total.



Remove the passenger side bumper bracket using a 21mm socket. (FIG 6)

**Aluminum JL Rear Bumper Installation Prep:**

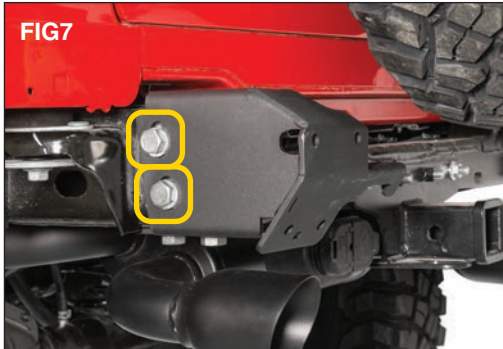

Using four M14 bolts and washers loosely install the driver's side bumper bracket using a 22mm socket. (FIG 7)

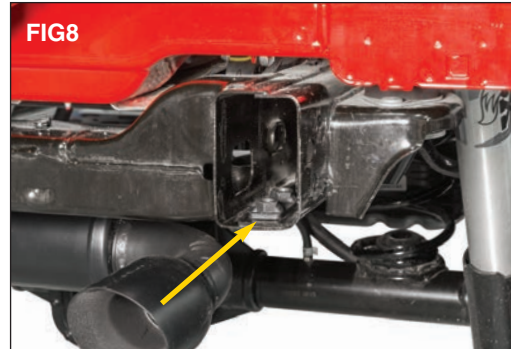

On the passenger side insert the nut plate into the frame rail. (FIG 8)

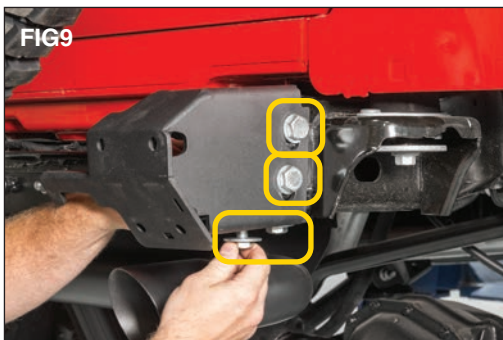

Using two M14 bolts and washers, two M12 bolts and washers loosely install the passenger side bumper bracket. (FIG 9) You can reach up into frame rail and hold the nut plate for easier installation.

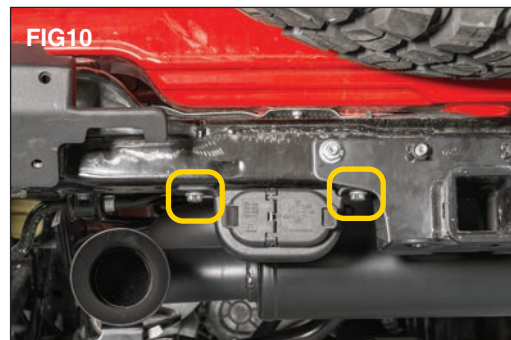

Using a 16mm socket remove the original hitch wiring plug from the frame. (FIG 10) Save these bolts for re-use.

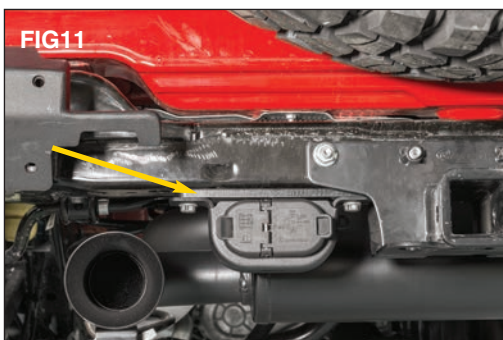

Re-install the hitch plug with the supplied spacer and original hardware. (FIG 11) Or, if you need more clearance for your hitch plug, use both provided spacers and the supplied M10 x 50 bolts.

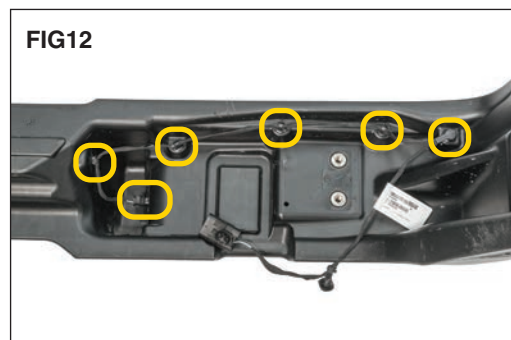

Remove the bumpers harness by gently prying on all tie wrap fasteners and disconnecting the license plate light. (FIG 12)

**Aluminum JL Rear Bumper Installation:**



Bumper harness **without** backup sensors shown. (FIG 13) This bumper is **not** designed to work with backup sensors. Retain harness for use with optional license plate light (#12066 1100)

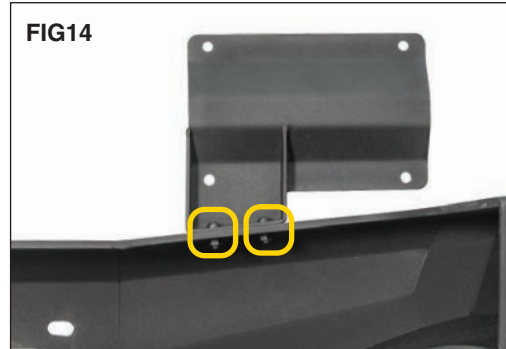

Install the license plate mount to the bumper using two M6 screws, four washers and two nuts. (FIG 14) The license plate will be installed with the remaining M6 hardware.



Loosely install the tow hooks through the bumper and into the bumper brackets with the supplied M10 allen head bolts and washers using a 6mm hex key. (FIG 15)



Once the bumper is aligned to your liking you may now tighten the M14 hardware to 105 ft/lbs and the M12 hardware to 65 ft/lbs.



Finally, you may now tighten the M10 allen head hardware through the tow hooks to 55 ft/lbs.

**Installation is now complete.**

### Aluminum JL Rear Bumper Installation:



Rear Bumper Shown installed with the Quadrtec D-Rings, and License Plate Light (sold separately)

### Bumper Care:

*Your Bumper has been designed and manufactured to provide years of use. However, like any product, general maintenance is required to keep it looking new.*

*Since the bumper is located on the front of the vehicle, it is subject to potential rock chips and other debris potentially causing portions of the paint to chip off. We recommend using a textured or gloss black spray paint sprayed on a piece of cardboard and Q-Tip to gently fill in*

*these chips. This will prevent any corrosion from forming. On all bumpers there is a chance of some surface corrosion showing over time due to metal particles being embedded in the paint. This surface corrosion is easily removed by a non-abrasive cleaner/polish and a soft bristle brush (not a metal brush!).*

*For bumpers with a textured finish, wash only with soapy water and avoid other waxes and polishes.*

# Quadratec® Exclusive Three Year Limited Warranty

Your Quadratec® branded accessories are covered by the following **Limited Warranty** provided exclusively by Quadratec, Inc., 1028 Saunders Lane, West Chester PA 19380.

This **Limited Warranty** is the only warranty made in connection with your purchase. Quadratec neither assumes nor authorizes any vendor, retailer or other person or entity to assume for it any other obligation or liability in connection with this product or **Limited Warranty**. This **Limited Warranty** does not apply and is not cumulative to any accessory or part distributed by Quadratec for which the Manufacturer provides a separate written warranty.

**What is Covered:** Subject to the terms, exclusions and limitations herein and with respect only to Quadratec branded accessories first sold in the United States, Quadratec warrants to the initial retail purchaser only that your Quadratec accessory shall be free of defects in material and workmanship: **for a period of three (3) years from date of retail purchase.**

This **Limited Warranty** is not assignable and shall terminate upon sale of the vehicle upon which the Quadratec accessory is installed or other transfer third persons.

All other warranties are hereby disclaimed, except to the extent prohibited by applicable law in which case any implied warranty of merchantability or fitness for a particular purpose on this product is limited to 3 year from date of initial retail sale. Quadratec reserves the rights to: (a.) require invoice or other proof your accessory is within the terms of this **Limited Warranty** as a condition of warranty service and, (b.) make future revisions to this product and **Limited Warranty** without prior notice or obligation to upgrade your product.

**What is Not Covered:**  
Your Quadratec **Limited Warranty** does not cover products or parts Quadratec determines to have been damaged by or subjected to:

(a.) installation damage, alteration, modification, combination with other parts, failure to maintain or improper repair or service, (b.) normal wear & tear, cosmetic damage or damage from moisture or water immersion, (c.) Acts of God, accidents, misuse, negligence, inadequate mounting or impact with vehicle(s), obstacles or other aspects of the environment, (d.) theft, vandalism or other intentional damage.

**Remedy Limited to Repair/Replacement:**  
**The exclusive remedy provided hereunder shall, upon Quadratec inspection and at Quadratec's option, be either repair or replacement of product or parts (new or refurbished) covered under this Limited Warranty.** Customers requesting warranty consideration should first contact Quadratec to obtain a RGA number (610-701-3336). All labor, removal, shipping and installation costs are customer's responsibility.

**Other Limitations - Exclusion of Damages - Your Rights Under State Law:**

In consideration of the purchase price paid, neither Quadratec nor any independent Quadratec distributor/licensee are responsible for any time loss, rental costs, or for any incidental, consequential, punitive or other damages you may have or incur in connection with any part or product purchased. Your exclusive remedy hereunder for covered parts is repair/replacement as described above.

This **Limited Warranty** gives you specific rights. You may also have other rights that vary from state to state. For example, some states do not allow limitations of how long an implied warranty lasts and /or do not allow the exclusion or limitation of incidental or consequential damages, so the limitations and exclusions herein may not apply to you.

©Quadratec, Inc. 2020. All Rights Reserved.  
A4 Version 2.17.20

Instructions Part #12999.3154

**Quadratec®**  
The Jeep® Experts