

Quadratec® Brute Strength Side Steps

Installation Manual for 4 Door '18-Current Wrangler JL Vehicles
#12057.0271



⚠ WARNING ⚠

TO REDUCE RISK OF SERIOUS INJURY OR PROPERTY DAMAGE: READ ALL SAFETY MESSAGES AND UNDERSTAND ALL INSTRUCTIONS AND PROCEDURE *NOTICES* BEFORE ATTEMPTING TO INSTALL OR USE THIS PRODUCT. FOLLOW ALL INSTRUCTIONS AND WARNINGS WITH PRODUCT & VEHICLE OWNERS MANUAL.

⚠ CAUTION ⚠

THIS PRODUCT IS INTENDED TO REDUCE RISK OF OFF-ROAD BODY PANEL DAMAGE AND ASSIST IN ENTRY/EXIT FROM VEHICLE. YOUR SIDE STEP IS NOT INTENDED TO INCREASE OCCUPANT PROTECTION OR REDUCE VEHICLE DAMAGE IN EVENT OF ACCIDENT.

⚠ CAUTION ⚠

PROPERLY TORQUE AND RECHECK FASTENERS AND SECURITY OF STEP TREAD AFTER 250 MILES AND FREQUENTLY THEREAFTER. INSPECT AND DO NOT USE AS A STEP IF DAMAGED.

⚠ CAUTION ⚠

DO NOT USE SIDE STEPS AS A WINCH/Self-RECOVERY ATTACHMENT POINT.

CHECK STATE AND LOCAL HIGHWAY SAFETY LAWS REGARDING PERMITTED ON-ROAD EQUIPMENT.

A Few Words About Product Safety:

Your Brute Strength Side Steps are designed to enhance the utility and enjoyment of your off road capable vehicle. Before installation, please take a moment to review the following

safety information and installation instructions. Important safety information is generally preceded by one of three signal words indicating the relative risk of injury. The signal words mean:

⚠ WARNING ⚠

A hazardous situation which, if not avoided, could result in death or serious injury. You CAN be KILLED or SERIOUSLY HURT if you don't follow instructions.

⚠ CAUTION ⚠

A hazardous situation which, if not avoided, could result in minor or moderate injury. You CAN be moderately HURT and also may suffer property damage if you don't follow instructions.

NOTICE

Careful attention is required to this instruction or operation but does generally not relate to personal injury. Damage to your Quadratec® product or other property may result if you don't follow instructions.

Before You Begin Installation:

Congratulations on your purchase of the Quadratec Brute Strength Side Steps for your Jeep® Wrangler.

Due to the length and bulk of these heavy duty side steps, we strongly suggest you get the help of a friend for steps that involve lifting, locating or holding the side steps during installation.

When unpacking, check to make sure all parts are included and not damaged due to shipping. If any part is missing or broken, please call Customer Service at 800-745-6037 as soon as possible.

Thank you again for your purchase and let's start the installation process.

NOTICE

AS YOU UNPACK YOUR SIDE STEPS, BE CAREFUL NOT TO SCRATCH THE FINISH WITH A KNIFE OR RAZOR. WE SUGGEST PLACING THE UNPACKED PIECES BACK INTO THE ORIGINAL BOX SO IT DOES NOT GET SCRATCHED BEFORE THE INSTALLATION BEGINS. IT IS HIGHLY RECOMMENDED THAT A SECOND PERSON ASSIST WITH THE INSTALLATION OF THESE SIDE STEPS.

Product Care and Maintenance:

These custom fit Side Steps have been designed for long life and great looks. With proper care, they are designed to provide years of use.

Please see page 5 in this instruction booklet for all suggested care for your product.

Quadratec®
The Jeep® Experts

Installation Hardware:

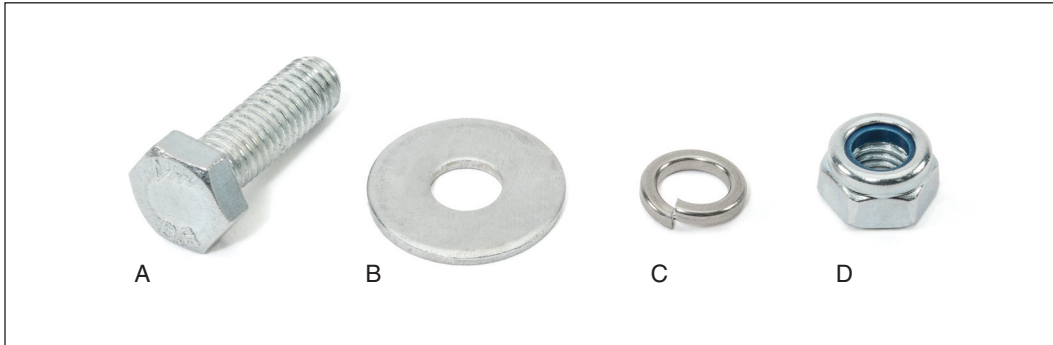

PARTS LIST:

Driver (Left) Side Step	QTY 1
Passenger (Right) Side Step	QTY 1
A) M8 x 25 mm Hex Bolts	QTY 18
B) 8mm Flat Washers	QTY 30
C) 8mm Lock Washers	QTY 6
D) 8mm nylock nut	QTY 12

Required Tools:

Safety Glasses
13mm Socket with Ratchet Driver
13mm Wrench

NOTICE

YOU MUST REMOVE ANY FACTORY INSTALLED "ROCK RAILS", SIDE STEPS OR RUNNING BOARDS BEFORE INSTALLATION OF YOUR NEW SIDE STEPS.

Brute Strength Side Steps Installation:

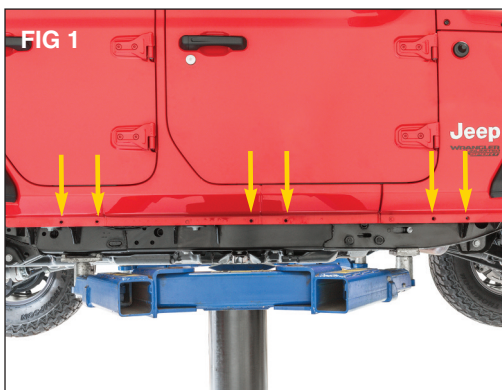

Put on safety glasses. Starting with the passenger side, locate the 6 holes along the factory pinch weld of your vehicle as shown. (FIG 1)



Starting at the front of the vehicle, position the mounting tabs of the side steps and align the holes with the factory pinch weld holes as shown. (FIG 2)

Quadratec
The Jeep® Experts

Brute Strength Side Steps Installation:



Install the 8mm hex head bolts through the pinch weld and the mounting brackets with washers on both sides and secure with a 8mm nylock nut using a 13mm hex wrench and a 13mm socket. (FIG 3)

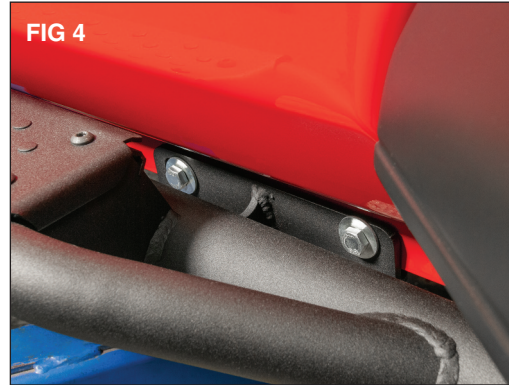

Do not fully tighten at this time. Repeat on the other side bracket holes. (FIG 4)

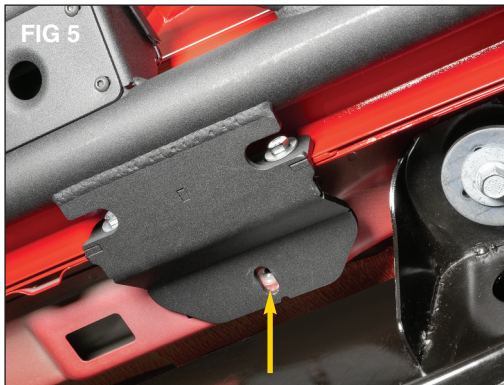

Locate the (3) vertical threaded holes behind the pinch weld. Align the holes in the brackets with these holes. (FIG 5) Install the 8mm hex bolts, lock washers, and washers using a 13mm socket. Repeat on other verticle holes. (FIG 6) Do not fully tighten at this time.



Then, holding the side step up on center with the pin weld holes fully tighten the 8mm pinch weld hardware. Once snug, you may now tighten the vertical 8mm bolts underneath. Repeat all steps on the opposite side. **Installation is complete.**

NOTICE

TORQUE FOR 8MM HEX HEAD BOLTS = 22 FT-LBS

Quadratec
The Jeep® Experts

Product Care and Maintenance:

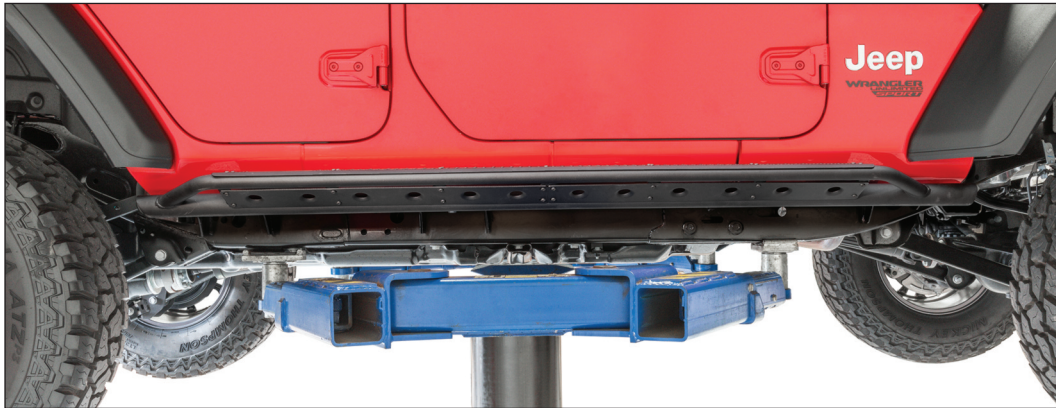

Your Side Steps have been designed and manufactured to provide years of use. However, like any product, general maintenance is required to keep them looking new.

For any required touch ups, we recommend using a textured black spray paint sprayed on a piece of cardboard and cotton swab to gently fill in these chips. This will prevent any rust from forming.

Because these are located on the underside of the vehicle, they are subject to potential rock chips and other debris potentially causing portions of the paint to chip off.

Quadratec® Exclusive Three Year Limited Warranty

Your Quadratec® branded accessories are covered by the following **Limited Warranty** provided exclusively by Quadratec, Inc., 1028 Saunders Lane, West Chester PA 19380.

This **Limited Warranty** is the only warranty made in connection with your purchase. Quadratec neither assumes nor authorizes any vendor, retailer or other person or entity to assume for it any other obligation or liability in connection with this product or **Limited Warranty**. This **Limited Warranty** does not apply and is not cumulative to any accessory or part distributed by Quadratec for which the Manufacturer provides a separate written warranty.

What is Covered: Subject to the terms, exclusions and limitations herein and with respect only to Quadratec branded accessories first sold in the United States, Quadratec warrants to the initial retail purchaser only that your Quadratec accessory shall be free of defects in material and workmanship: **for a period of three (3) years from date of retail purchase.**

This **Limited Warranty** is not assignable and shall terminate upon sale of the vehicle upon which the Quadratec accessory is installed or other transfer third persons.

All other warranties are hereby disclaimed, except to the extent prohibited by applicable law in which case any implied warranty of merchantability or fitness for a particular purpose on this product is limited to 3 year from date of initial retail sale. Quadratec reserves the rights to: (a.) require invoice or other proof your accessory is within the terms of this **Limited Warranty** as a condition of warranty service and, (b.) make future revisions to this product and **Limited Warranty** without prior notice or obligation to upgrade your product.

What is Not Covered:
Your Quadratec **Limited Warranty** does not cover products or parts Quadratec determines to have been damaged by or subjected to:

(a.) installation damage, alteration, modification, combination with other parts, failure to maintain or improper repair or service, (b.) normal wear & tear, cosmetic damage or damage from moisture or water immersion, (c.) Acts of God, accidents, misuse, negligence, inadequate mounting or impact with vehicle(s), obstacles or other aspects of the environment, (d.) theft, vandalism or other intentional damage.

Remedy Limited to Repair/Replacement:
The exclusive remedy provided hereunder shall, upon Quadratec inspection and at Quadratec's option, be either repair or replacement of product or parts (new or refurbished) covered under this **Limited Warranty**. Customers requesting warranty consideration should first contact Quadratec to obtain a RGA number (610-701-3336). All labor, removal, shipping and installation costs are customer's responsibility.

Other Limitations - Exclusion of Damages - Your Rights Under State Law:

In consideration of the purchase price paid, neither Quadratec nor any independent Quadratec distributor/licensee are responsible for any time loss, rental costs, or for any incidental, consequential, punitive or other damages you may have or incur in connection with any part or product purchased. Your exclusive remedy hereunder for covered parts is repair/replacement as described above.

This **Limited Warranty** gives you specific rights. You may also have other rights that vary from state to state. For example, some states do not allow limitations of how long an implied warranty lasts and /or do not allow the exclusion or limitation of incidental or consequential damages, so the limitations and exclusions herein may not apply to you.

©Quadratec, Inc. 2020. All Rights Reserved.
2.26.20 A4 Version

Part #12999.3138

Quadratec
The Jeep® Experts