

Quadratec® Large Cargo Receiver Rack

Assembly & Installation Manual: for 2" Receiver Hitches

#12033.1001



PARTS LIST:

Cargo Rack Halves - QTY 2

2" Receiver Tube Assembly - QTY 1

Connecting Plates - QTY 2

M12 x 75 Bolts - QTY 3

M12 Flat Washers - QTY 6

M12 Nylock Nuts - QTY 3

Plastic End Cap - QTY 1

Hitch Pin & Cotter Pin - One Each

M10 x 20 Carriage Bolts - QTY 8

M10 Flat Washers - QTY 8

M10 Nylock Nuts - QTY 8

REQUIRED TOOLS:

Safety Glasses

19mm Wrench & Socket

17mm Wrench or Socket

⚠ WARNING ⚠

TO REDUCE RISK OF SERIOUS INJURY OR PROPERTY DAMAGE: READ ALL SAFETY MESSAGES AND UNDERSTAND ALL INSTRUCTIONS AND PROCEDURE NOTICES BEFORE ATTEMPTING TO INSTALL OR USE THIS PRODUCT. FOLLOW ALL INSTRUCTIONS AND WARNINGS WITH PRODUCT & VEHICLE OWNERS MANUAL.

⚠ WARNING ⚠

REGARDING RECEIVERS: SEE PAGE 2 FOR URGENT RECEIVER CAPACITY WARNINGS. DO NOT ALLOW RECEIVER MOUNTED ACCESSORIES (RACKS, ETC.) TO BLOCK VEHICLE MIRRORS OR LIGHTS. READ AND UNDERSTAND ALL CAPACITY WARNINGS.

⚠ CAUTION ⚠

RISK OF EYE INJURY! SAFETY GLASSES MUST BE WORN AT ALL TIMES WHILE INSTALLING OR MAINTAINING THIS PRODUCT. TORQUE AND RECHECK FASTENERS AFTER 250 MILES AND FREQUENTLY THEREAFTER. INSPECT BUMPER AND MOUNT BEFORE USE. DO NOT USE IF DAMAGED.

NOTICE

CHECK STATE AND LOCAL HIGHWAY SAFETY LAWS REGARDING PERMITTED HITCH MOUNTED ACCESSORIES



The Trusted Source

A Few Words About Product Safety:

Your Receiver Mounted Cargo Rack is intended to enhance the utility and enjoyment of your off road capable vehicle. Before installation, please take a moment to review the following safety information, assembly and installation

instructions. Important safety information is generally preceded by one of three signal words indicating the relative risk of injury.

The signal words mean:

⚠ WARNING ⚠	a hazardous situation which, if not avoided, could result in death or serious injury. You CAN be KILLED or SERIOUSLY HURT if you don't follow instructions.
⚠ CAUTION ⚠	a hazardous situation which, if not avoided, could result in minor or moderate injury. You CAN be moderately HURT and also may suffer property damage if you don't follow instructions.
NOTICE	Careful attention is required to this instruction or operation but does generally not relate to personal injury. Damage to your Quadratec® product or other property may result if you don't follow instructions.

Before You Begin Installation:

Congratulations on your purchase of a Quadratec Cargo Receiver Rack. This version is specifically designed for use with a 2" receiver style hitch.

As cargo racks tend to be bulky, we suggest you get help for steps involving lifting, locating or holding the rack assembly during installation.

When unpacking, check to make sure all parts are included and not damaged due to shipping. If any part is missing or broken, please call Customer Service at 800-745-6037 as soon as possible.

Thank you again for your purchase and let's start the installation process.

⚠ WARNING ⚠	THIS IS DESIGNED FOR A CLASS II RECEIVER THE RACK IS RATED FOR A MAXIMUM OF 500 LBS CONSULT & NEVER EXCEED LESSER OF VEHICLE, RECEIVER OR TRAILER MAXIMUM TOW OR WEIGHT RATINGS.
⚠ WARNING ⚠	DO NOT BLOCK TAILLIGHTS OR LICENSE PLATE WITH CARGO LOAD.
⚠ WARNING ⚠	CONSULT AND FOLLOW ALL LIMITATIONS & WARNINGS IN YOUR VEHICLE OWNERS MANUAL AND SAFE TOWING SUPPLEMENT.
⚠ WARNING ⚠	SECURELY FASTEN LOAD TO CARGO CARRIER. ATTACH STRAPS AND/OR TIE DOWN HOOKS TO THE TUBULAR FRAME OF CARGO RACK. DO NOT CARRY ANY LOADS WIDER THAN YOUR VEHICLE.
⚠ WARNING ⚠	TO REDUCE RISK OF SERIOUS INJURY OR PROPERTY DAMAGE: INSTALL ACCORDING TO INSTRUCTIONS. TORQUE AND RECHECK FASTENERS AFTER 250 MILES AND FREQUENTLY THEREAFTER. INSPECT AND DO NOT USE RECEIVER/BUMPER IF DAMAGED.



The Trusted Source

Cargo Rack Kits Contents:

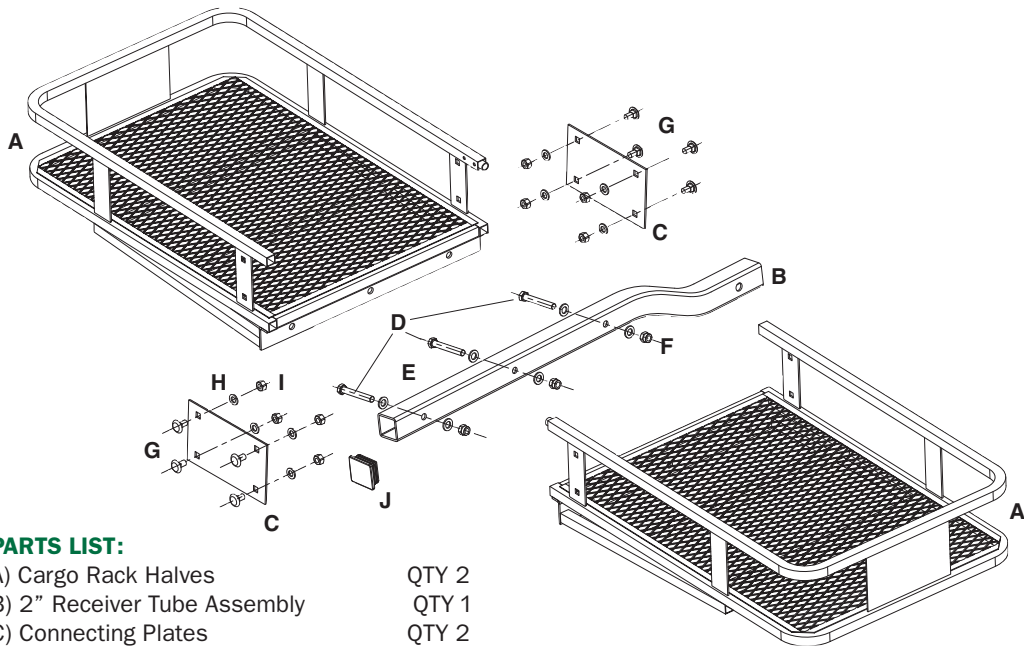

PARTS LIST:

A) Cargo Rack Halves	QTY 2
B) 2" Receiver Tube Assembly	QTY 1
C) Connecting Plates	QTY 2
D) M12 x 75 Bolts	QTY 3
E) M12 Flat Washer	QTY 6
F) M12 Nylock Nuts	QTY 3
G) M10 x 20 Carriage Bolts	QTY 8
H) M10 Flat Washers	QTY 8
I) M10 Nylock Nuts	QTY 8
J) Plastic End Cap	QTY 1
Hitch Pin & Cotter Pin - One Each	

REQUIRED TOOLS:

- Safety Glasses
- 19mm Wrench & Socket
- 17mm Wrench or Socket

Assembly Instructions:

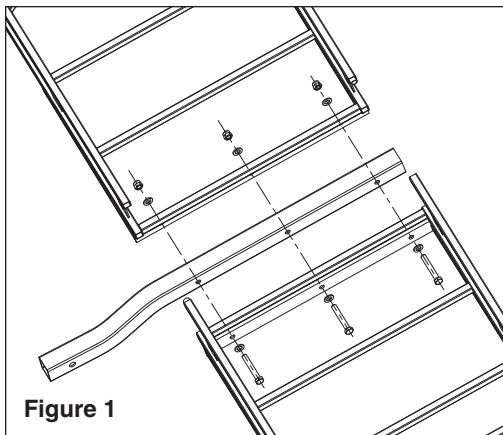

Figure 1

Put on safety glasses.

Position the 2" tube assembly between the two rack halves. Install the (3) M12 bolts through both Cargo Rack halves and the 2" tube along with (6) M12 washers and the (3) M12 nylock nuts.

Snug the fasteners using (2) 19mm wrenches or a wrench and a 19mm socket. Do not fully tighten at this time.



The Trusted Source

Cargo Rack Assembly & Installation:

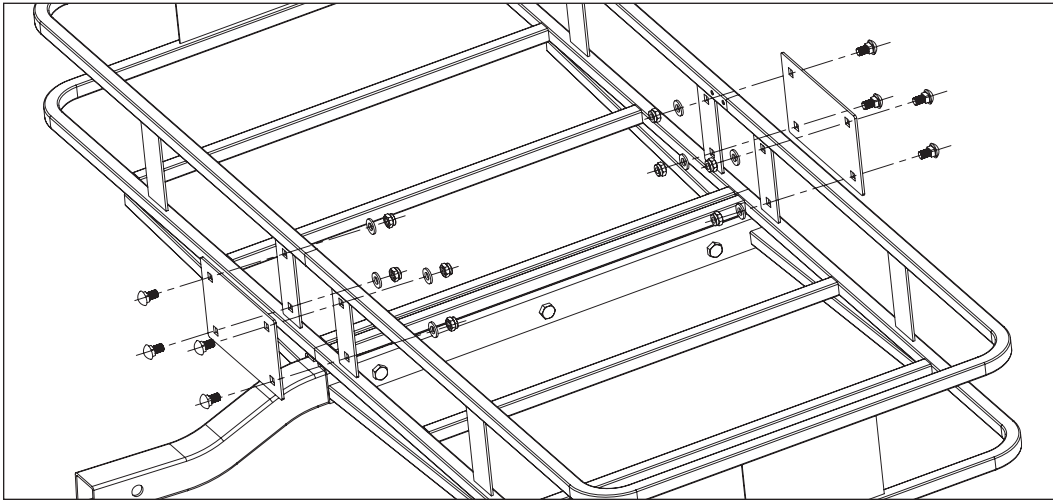

Place the 2 connecting plates on either side of the rack. Secure the plates in

place with 4 M10 carriage bolts along with the M10 washers and nylock nuts.

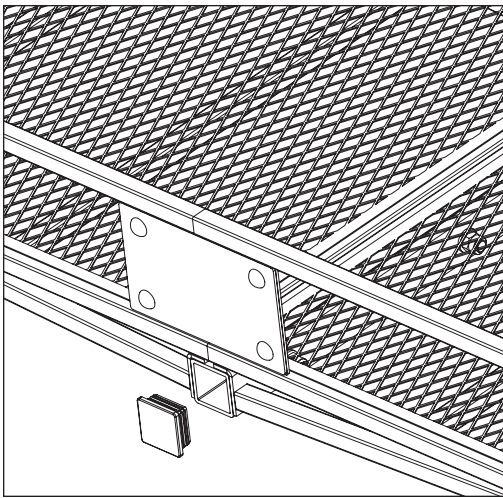

Insert the plastic plug into the end of the tube. At this time, tighten all M10 and M12 fasteners.



Install the rack into your 2" receiver hitch and secure with the supplied 5/8" receiver pin and cotter pin.

Instructions Part #12999.3019



The Trusted Source