

Installation Instructions

Jeep Wrangler JL & JL Unlimited
Jeep Gladiator

IS-99512 Rev.A



Trail Guard Front Bumper

For proper installation and best possible fit, please read all instructions BEFORE you begin.
For technical assistance or to obtain missing parts, please call Customer Relations at 1-800-328-2409.

Important Safety Information



- CAUTION - Before driving, ensure that the bumper is properly secured to vehicle.
- Periodically check all components for tightness.

Contents

NOTE: Actual product may vary from illustration.

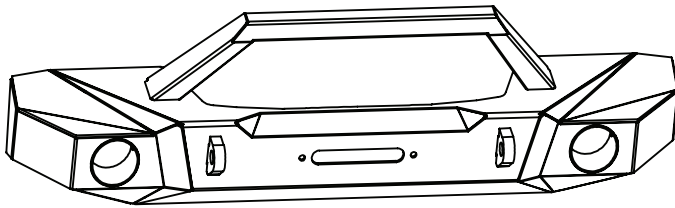

Trail Guard Bumper



D-Ring Shackles (2)



4mm x 15mm Bolt (14)



4mm Flat Washer (24)

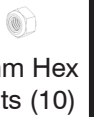

4mm Hex Nuts (10)

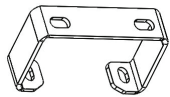

Fog Light Bracket



10mm x 35mm Bolt (4)



10mm Lock Washer (8)



10mm Flat Washer (8)



10mm Nut (4)

Tools Required

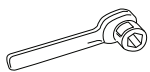

Socket Wrench



Socket Set

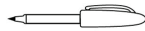

Marker

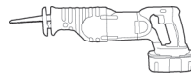

Cutting Tool
(If installing large body Winch)



Safety glasses

Before Installation

Remove factory front bumper, skid plate and fog lights per OEM standards.

Fog Lights

The JL Wrangler has multiple fog light mounting variations from the factory. The Rampage Bumper you have purchased is compatible with the 4-bolt and 3-bolt versions. **See Figure 1**

A third factory fog light, a 2-bolt version is not compatible. The 2-bolt fog light comes on the factory steel winch ready bumper. If your vehicle has this bumper, you will need to purchase Rampage fog lights to complete your installation.

Figure 1

4-Bolt Factory Fog Light

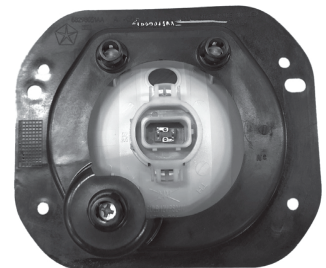

3-Bolt Factory Fog Light

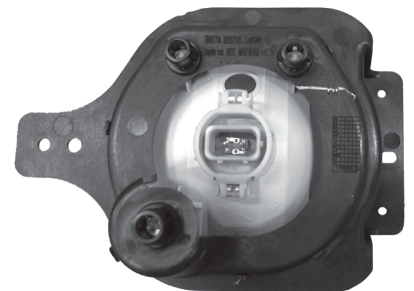

1

Install fog lights.

4-Bolt fog lights: See Figure 2. Using the provided 4mm hardware, bolt the provided bracket to the bumper at the points shown at **A**. Then bolt the fog light using the points shown at **B**.

3-Bolt fog lights: See Figure 3. Using the provided 4mm hardware, bolt the fog light using the points shown at **C**.

Rampage fog lights: See Figure 4. Using the hardware provided with the fog lights, bolt the fog light using the points shown at **D**.

Figure 2

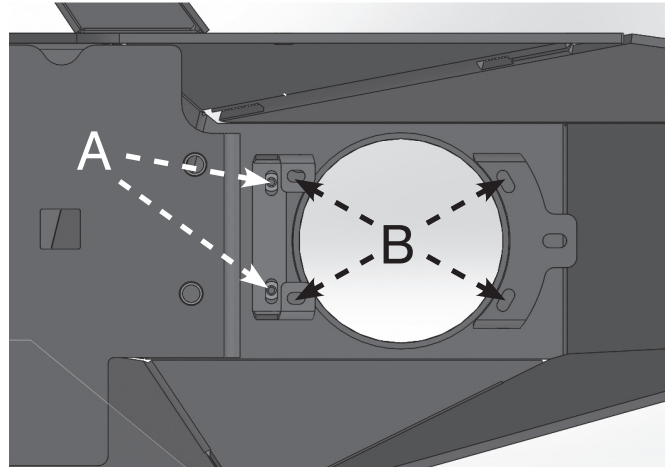

Figure 3

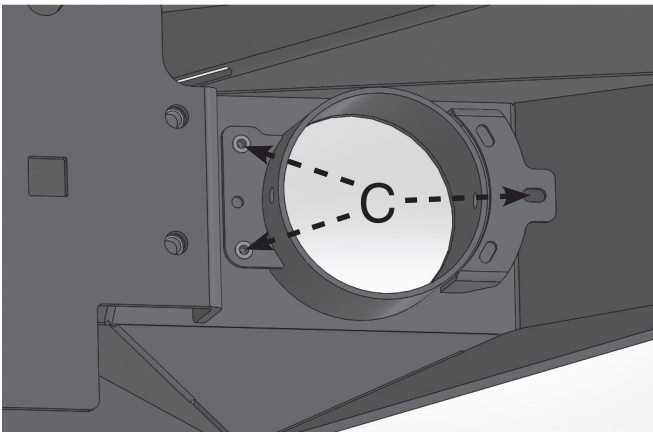
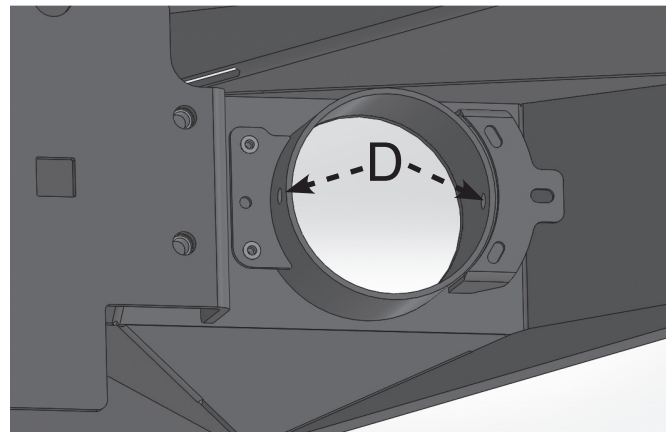
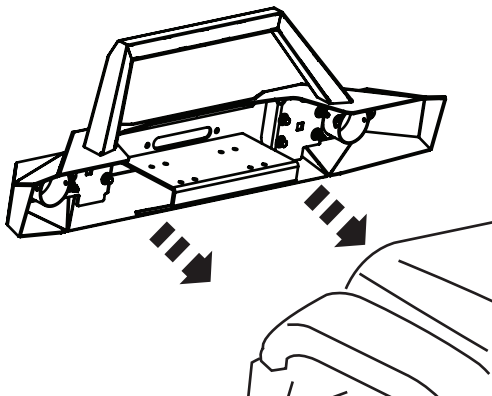

Figure 4



2

Place front bumper on the frame lining up holes.
Caution: 2 person lift.



3

Install (2) nuts and (2) bolts with (2) washers and (2) lock washers on each frame rail. Check bumper adjustment before tightening hardware.

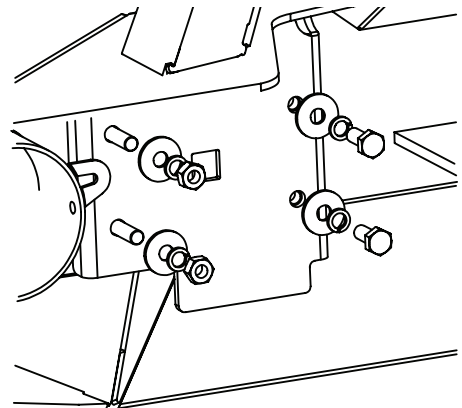

3

Reconnect the fog lights and route the wiring harness so that it does not hang below the bumper.

4

Test fit winch on built in winch plate. **See Figure 5.** Follow winch manufacturer's installation guidelines.

Some winches (such as the Warn Zeon series) will require trimming the frame horn for clearance.

Measure 3/8" (10mm) from the inside top edge shown in **Figure 6.** Carefully trim the frame on both the left and right frame horns.

Figure 5

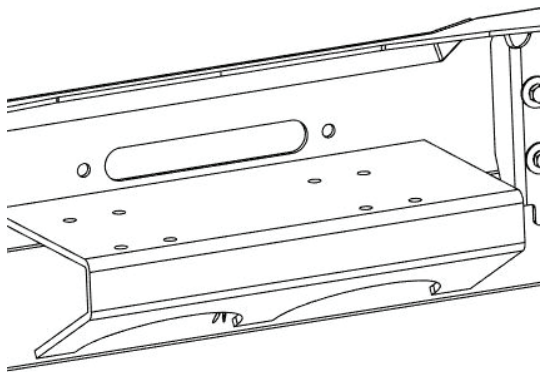
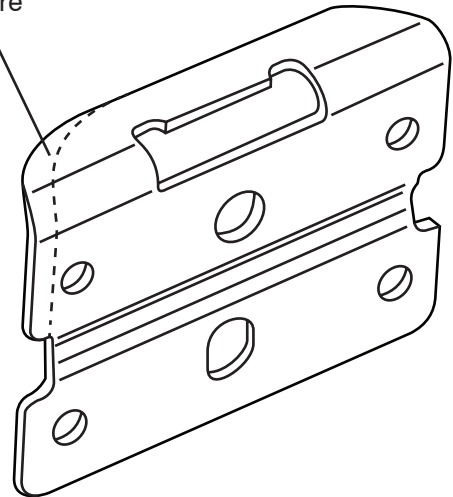

Figure 6

Left Front Frame Horn Shown

Trim Here



Care and Cleaning

- Rampage Bumpers are built to last; any detergent you use to wash your vehicle is sufficient to clean the bumper. Do not use any harsh abrasive detergents. Periodically check and retighten hardware.

Congratulations!

You have purchased one of the many quality Rampage branded products offered by Lund International. We take the utmost pride in our products and want you to enjoy years of satisfaction from your investment. We have made every effort to ensure that your product is top quality in terms of fit, durability, finish and ease of installation.



The material that your product is made from can be recycled. Please also consider recycling the packaging that your product came in.



800-328-2409 • Visit us at Rampageproducts.com
© 2018 Lund Motion Products, Inc. All rights reserved.
Rampage Products™ is a trademark of Lund Motion Products, Inc.



Instructions d'installation

Jeep Wrangler JL & JL Unlimited
Jeep Gladiator



IS-99512 Rev.A

Trail Guard Front Bumper

Pour une installation correcte et un ajustement optimal, veuillez lire toutes les instructions AVANT de commencer.
Pour obtenir une assistance technique ou pour obtenir des pièces manquantes, veuillez appeler le service à la clientèle au 1-800-328-2409.

Informations de sécurité importantes



- ATTENTION - Avant de conduire, assurez-vous que le pare-chocs est correctement fixé au véhicule.
- Vérifiez régulièrement que tous les composants sont bien serrés.

Contenu

REMARQUE: Le produit réel peut différer de l'illustration.

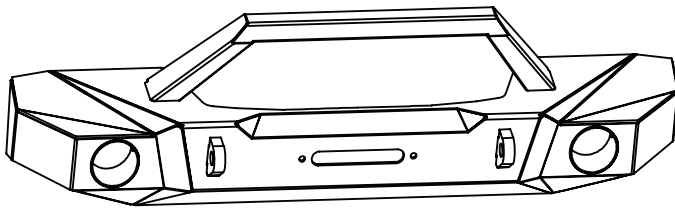

Trail Guard Bumper



Anneaux D-Ring (2)



4mm x 15mm Boulon (14)



Rondelle plate 4mm (24)

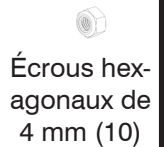

Écrous hexagonaux de 4 mm (10)

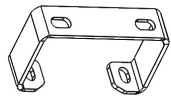

Support antibrouillard

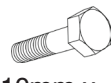

10mm x 35mm Boulon (4)



10mm Rondelle De Verrouillage (8)



Rondelle plate de 10mm (8)



Écrou 10mm (4)

Outils nécessaires



Clé à douille



Jeu de douilles

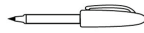

Marqueur

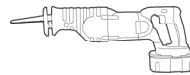

Outil de coupe (Si vous installez un grand treuil)



Lunettes de protection

Avant l'installation

Retirez le pare-chocs avant, la plaque de protection et les phares antibrouillard selon les normes OEM.

Feux de brouillard

Le JL Wrangler a de multiples variantes de montage des phares antibrouillard. Le rampage Le pare-chocs que vous avez acheté est compatible avec les versions à 4 et 3 boulons. Voir la figure 1

Un troisième phare antibrouillard, une version à 2 boulons n'est pas compatible. Le feu antibrouillard à 2 boulons est fourni sur le pare-chocs prêt à l'emploi. Si votre véhicule est équipé de ce pare-chocs, vous devrez acheter des phares antibrouillard Rampage pour compléter votre installation.

Figure 1

Projecteur antibrouillard à 4 boulons

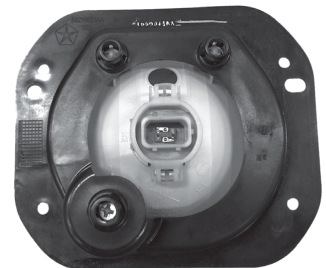

Feu antibrouillard à 3 boulons

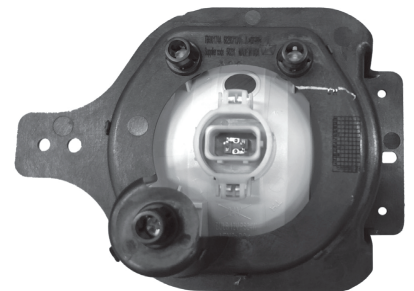

1

Installez des phares antibrouillard.

Phares antibrouillard à 4 boulons: voir la figure 2. À l'aide de la quincaillerie de 4 mm fournie, boulonnez le support fourni au pare-chocs aux points indiqués en A. Vissez ensuite le phare antibrouillard en utilisant les points indiqués en B.

Phares antibrouillard à 3 boulons: voir la figure 3. À l'aide du matériel de 4 mm fourni, boulonnez le phare antibrouillard en utilisant les points indiqués en C.

Phares antibrouillard: Voir la figure 4. À l'aide du matériel fourni avec les phares antibrouillard, vissez le feu antibrouillard en utilisant les points indiqués en D.

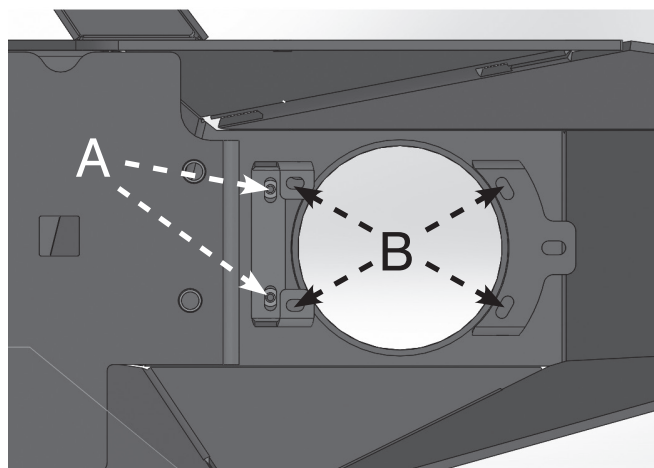
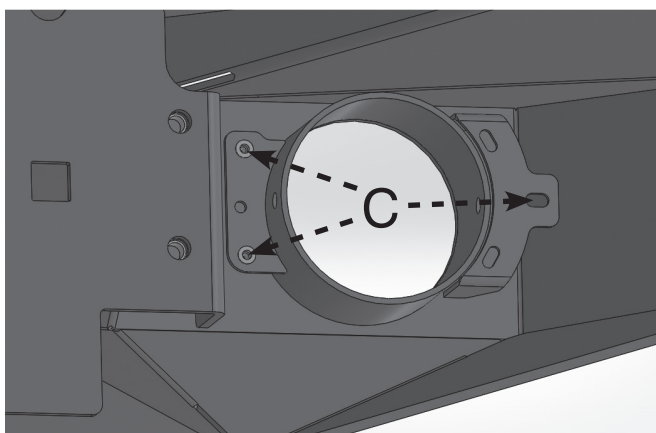
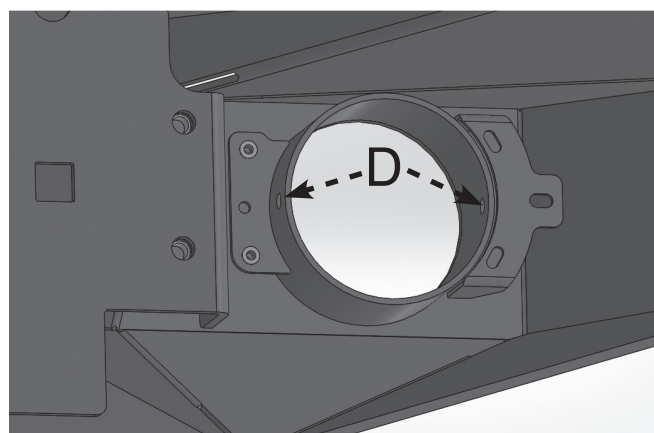
Figure 2**Figure 3****Figure 4****2**

Placez le pare-chocs avant sur les trous alignés du cadre.

Attention: ascenseur pour 2 personnes.

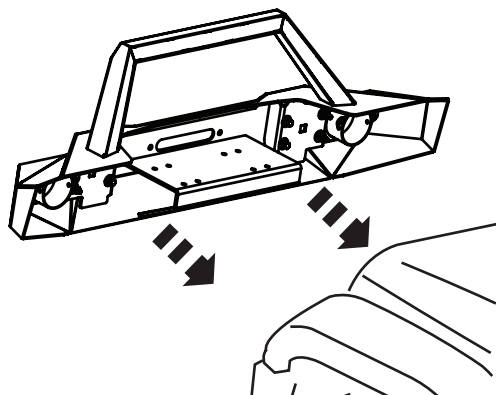
**3**

Installez deux (2) écrous et (2) boulons avec (2) rondelles et (2) rondelles de blocage sur chaque longeron. Vérifiez le réglage du pare-chocs avant de serrer le matériel.

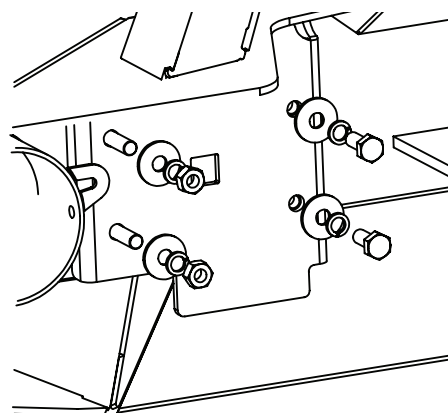

3

Rebranchez les phares antibrouillard et acheminez le faisceau de câbles de manière à ce qu'il ne repose pas sous le pare-chocs.

4

Tester le treuil sur la plaque de treuil intégrée. Voir la figure 5. Suivez les directives d'installation du fabricant du treuil.

Certains treuils (tels que la série Warn Zeon) nécessiteront un réglage du cornet du cadre pour le dégagement.

Mesurez à 3/8 po (10 mm) du bord supérieur intérieur illustré à la Figure 6. Coupez délicatement le cadre sur les cornes du cadre gauche et droit.

Figure 5

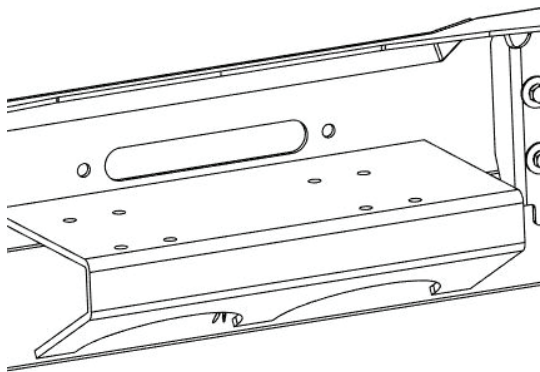
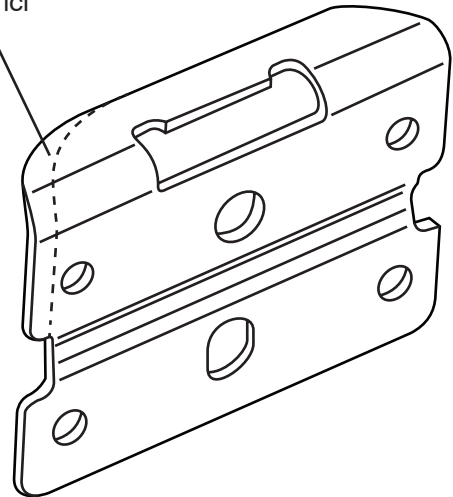

Figure 6

Avant gauche cadre corne montré

Couper ici



Soins et nettoyage

- Les pare-chocs Rampage sont conçus pour durer; tout détergent que vous utilisez pour laver votre véhicule est suffisant pour nettoyer le pare-chocs. N'utilisez pas de détergents abrasifs durs. Vérifiez régulièrement et resserrez le matériel.

Félicitations!

Vous avez acheté l'un des nombreux produits de qualité Rampage proposés par Lund International. Nous tirons une grande fierté de nos produits et souhaitons que vous profitiez de nombreuses années de votre investissement. Nous nous sommes efforcés de garantir la qualité supérieure de votre produit en termes d'ajustement, de durabilité, de finition et de facilité d'installation.



Le matériau à partir duquel votre produit est fabriqué peut être recyclé. Veuillez également envisager de recycler l'emballage dans lequel votre produit est entré.



800-328-2409 • Rendez-vous sur Rampageproducts.com

© 2018 Lund Motion Products, Inc. Tous droits réservés.

Rampage Products™ est une marque commerciale de Lund Motion Products, Inc.



Instrucciones de instalación

Jeep Wrangler JL & JL Unlimited
Jeep Gladiator



IS-99512 Rev.A

Trail Guard Front Bumper

Para una instalación adecuada y el mejor ajuste posible, lea todas las instrucciones ANTES de comenzar.
Para asistencia técnica o para obtener piezas faltantes, llame a Atención al Cliente al 1-800-328-2409.

Información de Seguridad Importante



- **PRECAUCION:** antes de conducir, asegúrese de que el parachoques esté correctamente asegurado al vehículo.
- Verifique periódicamente que todos los componentes estén apretados.

Contents

NOTA: El producto real puede variar de la ilustración.

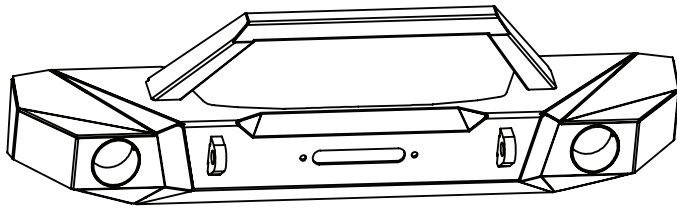

Trail Guard Bumper



Anillos en D (2)



Perno de 4 mm x 15 mm (14)



Arandela plana de 4 mm (24)



Tuercas hexagonales de 4 mm (10)

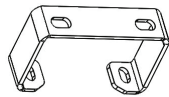

Soporte de luz antiniebla

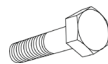

Perno de 10 mm x 35 mm (4)



Arandela de seguridad de 10 mm (8)



Arandela plana de 10 mm (8)



Tuerca de 10 mm (4)

Herramientas necesarias



Llave de tubo



Juego de zócalos



Marcador

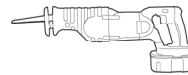

Herramienta para cortar (Si instala Winch de cuerpo grande)



Lentes de seguridad

Antes de la instalación

Retire el paragolpes delantero de fábrica, la placa de deslizamiento y las luces antiniebla de acuerdo con las normas OEM.

Faros antiniebla

El JL Wrangler tiene múltiples variaciones de montaje de la luz antiniebla de fábrica. El alboroto El parachoques que ha comprado es compatible con las versiones de 4 pernos y 3 pernos. Ver la Figura 1

Una tercera luz de niebla de fábrica, una versión de 2 pernos no es compatible. La luz antiniebla de 2 pernos viene en el parachoques listo para fábrica de acero del cabrestante. Si su vehículo tiene este parachoques, deberá comprar luces antiniebla Rampage para completar su instalación.

Figura 1

Luz antiniebla de fábrica de 4 pernos

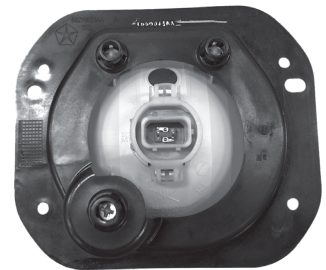

3-Bolt Factory Luz de niebla

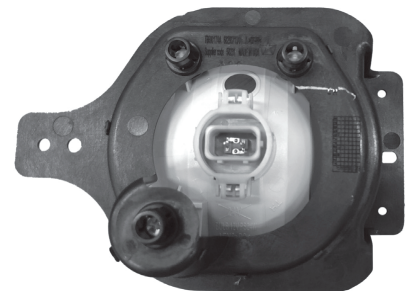

1

Instale luces antiniebla.

Faros antiniebla de 4 pernos: Ver Figura 2.
Usando el hardware provisto de 4 mm, atornille el soporte provisto al parachoques en los puntos mostrados en A. Luego atornille el faro antiniebla usando los puntos mostrados en B.

Faros antiniebla de 3 pernos: consulte la figura 3. Con el hardware provisto de 4 mm, atornille el faro antiniebla con los puntos que se muestran en C.

Luces antiniebla de Rampage: Vea la Figura 4. Usando el hardware proporcionado con los faros antiniebla, atornille la luz antiniebla usando los puntos que se muestran en D.

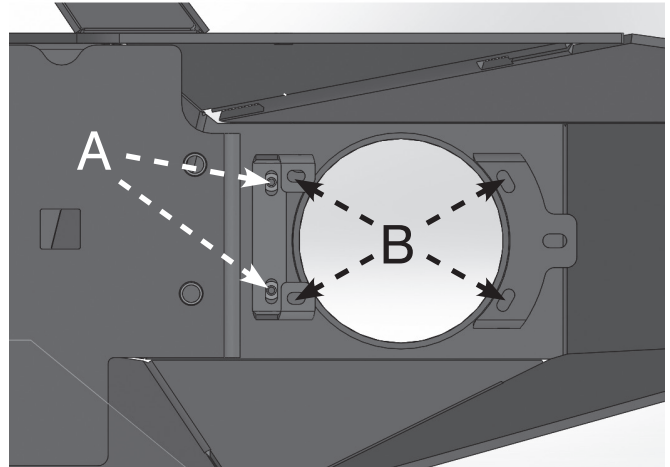
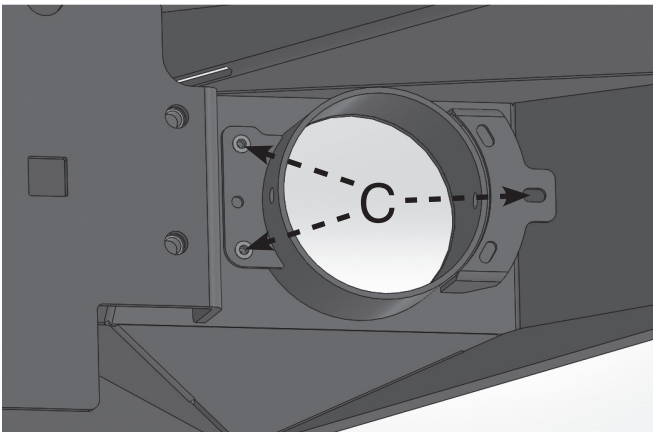
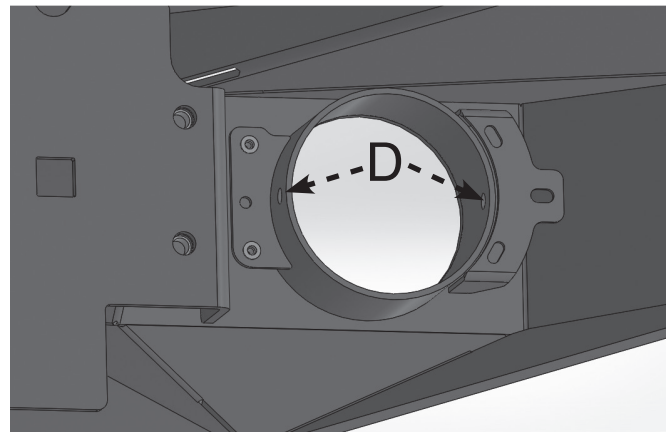
Figura 2**Figura 3****Figura 4****2**

Coloque el parachoques delantero en el marco alineando los agujeros.
Precaución: elevación de 2 personas.

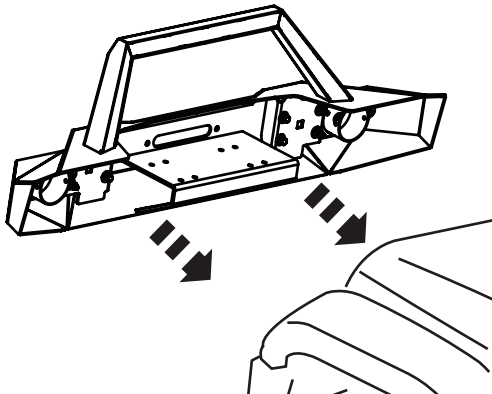
**3**

Instale (2) tuercas y (2) pernos con (2) arandelas y (2) arandelas de seguridad en cada riel del marco. Verifique el ajuste del parachoques antes de apretar el hardware.

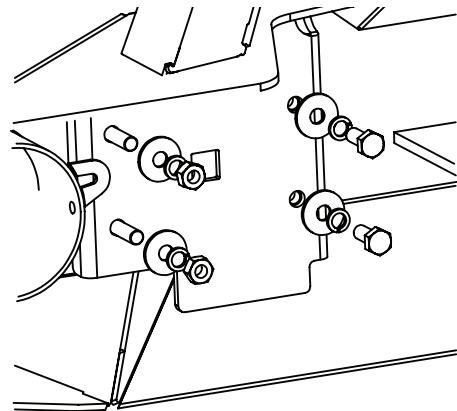

3

Vuelva a conectar los faros antiniebla y pase el mazo de cables para que no quede colgando debajo del parachoques.

4

Pruebe el cabrestante en la placa de cabrestante incorporada. Vea la Figura 5. Siga las instrucciones de instalación del fabricante del cabrestante.

Algunos winches (como la serie Warn Zeon) requerirán recortar la bocina del bastidor para su despeje.

Mida 3/8 " (10 mm) desde el borde superior interior que se muestra en la Figura 6. Corte con cuidado el marco tanto en los cuernos del marco izquierdo como derecho.

Figura 5



Figura 6

Se muestra el chasis delantero izquierdo del cuerno

Recortar aquí

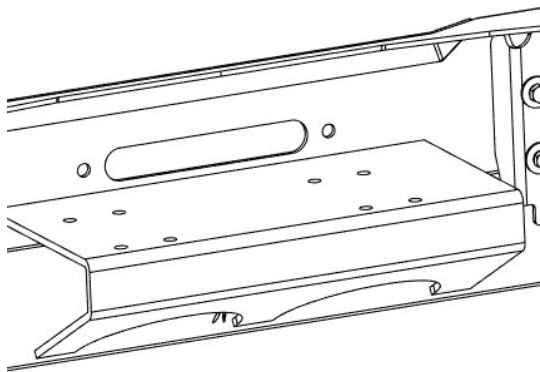
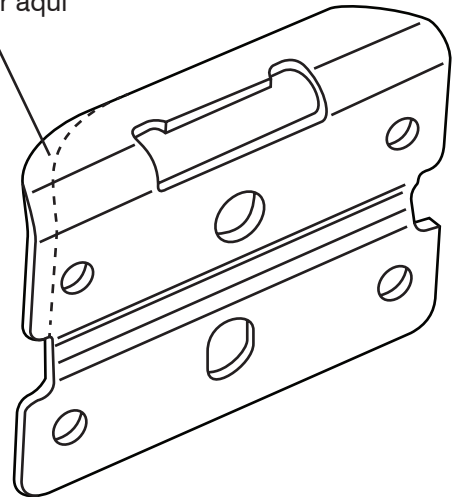

Cuidado y Limpieza

- Los parachoques Rampage están diseñados para durar; cualquier detergente que use para lavar su vehículo es suficiente para limpiar el parachoques. No use detergentes abrasivos fuertes. Periódicamente revise y vuelva a apretar el hardware.

¡Felicidades!

Usted ha comprado uno de los muchos productos de calidad Rampage ofrecidos por Lund International. Nos enorgullecemos de nuestros productos y queremos que disfrute años de satisfacción de su inversión. Hemos hecho todos los esfuerzos posibles para garantizar que su producto sea de alta calidad en términos de ajuste, durabilidad, acabado y facilidad de instalación.



El material del que está hecho su producto puede reciclarse. Considere también reciclar el embalaje en el que entró su producto.



800-328-2409 • Visítanos en Rampageproducts.com
© 2018 Lund Motion Products, Inc. Todos los derechos reservados.
Rampage Products™ es una marca registrada de Lund Motion Products, Inc.

