



## Rancho Suspension System — RS66115B

4" Long Arm System — Black

Fits 2017-2007 Jeep Wrangler JK

**Requires Additional Components to be Purchased Separately,**

**See Page 4 for Additional Components and Requirements for Installation.**

This suspension system was developed using 35x12.5xR17 tires. Before installing any other size tire, consult your local tire and wheel specialist.



### **⚠ WARNING**

Carefully read, understand and follow the instructions provided in this manual, and keep it in a safe place for future reference. If you have any doubt whatsoever regarding the installation or maintenance of your Rancho suspension system, please see your retailer for assistance or advice. Failure to follow the warnings and instructions provided herein can result in the failure of the suspension system, or can cause you to lose control of your vehicle, resulting in an accident, severe personal injury or death.

These instructions should remain in the vehicle glove box for future reference.

**⚠ WARNING: READ ALL INSTRUCTIONS THOROUGHLY FROM START TO FINISH BEFORE BEGINNING INSTALLATION. Failure to follow the warnings and instructions provided herein can result in an accident, severe personal injury or death.**

## **PRELIMINARY**

This manual presumes that all persons installing this suspension system have a high level of mechanical training and experience, and have available to them all necessary tools and safety equipment. This manual is not and should not be construed as an exhaustive list of all required safety measures. Personnel should rely primarily on their training and experience, as well as on their own common sense.

This Manual is to be read as a supplement to, and must not be construed as a substitute for, the owner's manual and/or shop manual that originally accompanied the vehicle. Refer to such use, operation, maintenance and safety manuals as necessary, and especially after installation is complete, to insure proper vehicle operation.

The following terminology has been used in this Manual:

**ACCIDENT:** Any event which could cause personal injury or death to anyone installing or using the suspension system, as well as to passengers and bystanders, or otherwise may result in property damage.

## **PRE-INSTALLATION WARNINGS and INSTRUCTIONS**

**⚠ WARNING: Only the following wheel / tire size may be used with this suspension system: 35 x 12.50 R17 tires, 17" x 9" wheel with 4.5" of backspacing.**

**Use of any other rim/tire combination increases the risk of a roll-over and/or accident, resulting in severe personal injury or death.**

**⚠ WARNING: This suspension system will enhance the off-road performance of your vehicle. It will handle differently; both on and off-road, from a factory equipped passenger car or truck. Failure to drive this vehicle safely may result in serious injury or death to the driver and passengers. ALWAYS WEAR your seat belts, REDUCE your speed, and AVOID sharp turns and other abrupt maneuvers.**

- 1) Service and repair tasks require specialized knowledge, training, tools, and experience. General mechanical aptitude may not be sufficient to properly install this suspension system. If you have any doubt whatsoever regarding your ability to properly install the suspension system, please consult a qualified mechanic.
- 2) Your brake lines and fuel lines should remain undisturbed during and after installation. If you think you need to modify these components in any way, you are mistaken. You are installing the lift improperly and will be creating a significant risk of an accident. In case of any doubt, consult a qualified mechanic.
- 3) If any component does not fit properly, something is wrong. You are installing the lift kit improperly and will be creating a significant risk of an accident. Never modify any component of the vehicle or suspension system, except as instructed herein. Do not continue with installation until you have identified the problem.
- 4) Several of the procedures described herein require at least two (2) persons to safely complete the task. If you have any doubt about your ability to complete any operation by yourself, always ask for help from a qualified assistant.
- 5) Before starting any operation, confirm that all personal safety devices and safety equipment are in proper condition and position.
- 6) Give your work undivided attention. Looking around, carrying on a conversation and "horse-play" are careless acts that can result in an error in installation and/or serious injury.

7) Install only tires approved by the United States Department of Transportation ("DOT approved"). Make sure the rim and tire size are properly matched.

8) If any components of the vehicle or suspension system are damaged in any way during installation, immediately replace the component.

9) During installation, carefully inspect all parts of the vehicle and replace anything that is worn or damaged.

10) Nip points present the risk of the catching, lacerating, crushing and/or amputating fingers, hands, limbs and other body parts during operations. Always keep clear. Wear protective gloves.

11) Oil and hydraulic fluids are poisonous, dangerous to health and are known to the State of California to cause cancer, birth defects or other reproductive harm. Do not inhale vapors or swallow. Do not allow contact with the eyes or skin. Should any oil or fluids be swallowed or inhaled or come into contact with the eyes, immediately follow the safety precautions on the label or call a poison control center immediately. Should any of the oil or fluids contact your skin, immediately wash thoroughly.

12) Never install the suspension system if you are under the effects of alcohol, medications and/or drugs. If you are taking prescription or over the counter medication, you must consult a medical professional regarding any side effects of the medication that could hinder your ability to work safely.

## **AFTER INSTALLATION WARNINGS AND INSTRUCTIONS**

13) After installation is complete, drive the vehicle slowly in an area free from heavy traffic for at least three (3) miles. Likewise, before traveling on any highways or at a high rate of speed, drive the vehicle for ten (10) miles on side roads at moderate speed. If you hear any strange noise or feel unusual vibration, if a component of the suspension system is not operating properly, or if any warning lights illuminate or buzzers sound, stop the vehicle immediately. Identify the cause and take any necessary remedial action.

14) Confirm that all components of the vehicle, including all lights (headlights, turn signals, brake lights, etc.), linkages (accelerator, etc.), electrical switches and controls (windshield wipers and defoggers, etc.), and other warning devices (low tire pressure monitoring systems) are fully operational.

15) Your headlights will need to be readjusted before the vehicle is used on the roads. Consult the vehicle owners' manual.

16) The speedometer and odometer will need to be recalibrated after installation. See your dealer.

17) Confirm proper rear view and side view while seated in the driver seat. Install supplemental mirrors as necessary.

18) Your original low tire pressure monitoring system may be re-installed in your new wheels. However, if you choose to purchase a new system, see your dealer to have them properly calibrated. Proper tire pressure is critical to safe operation of the vehicle.

## **OPERATION**

19) Because it has been modified, the vehicle will not handle, turn, accelerate or stop in the same manner as an unmodified vehicle. In addition, the crash protection systems designed in the vehicle may operate differently from an unmodified vehicle. For example, turning and evasive maneuvers must be executed at a slower rate of speed. Further, there is a greater risk that the vehicle could roll over. These differences could result in an increased possibility of an accident, personal injury or death. Learn the vehicle's operations and handling characterizes and drive accordantly.

## **IMPORTANT NOTES**

- A. Before installing this system, have the vehicle's alignment and frame checked by a certified technician. The alignment must be within factory specifications and the frame of the vehicle must be sound (no cracks, damage or corrosion). Have all suspension, steering and driveline components inspected and replaced if worn or damaged
- B. The components of Rancho's suspension system are designed as a single integrated system. To avoid compromises in terms of safety, performance, durability or function, do not install a body lift kit with Rancho's suspension system or interchange parts from this system with components from another manufacturer. Use of other components will result in the forfeiture of any type of warranty on the vehicle/suspension system.
- C. Some components required for the installation of this kit may need to be purchased separately. See "SPECIFICATIONS & REQUIREMENTS" on next page of this manual.
- D. Compare the contents of this system with the parts list in these instructions. If any parts are missing, contact the Rancho Technical Department at 1-734-384-7804.
- E. Do not powder-coat or plate any of the components in this system. To change the appearance of components, automotive paint can be applied over the original coating.
- F. Each hardware kit in this system contains fasteners of high strength and specific size. Do not mix hardware kits or substitute a fastener of lesser strength. See bolt identification table at end of instruction.
- G. Install all nuts and bolts with a flat washer. When both SAE (small OD) and USS (large OD) washers are used in a fastener assembly, place the USS washer against the slotted hole and the SAE washer against the round hole.
- H. Apply a drop of thread locking compound to all bolts during installation. ⚠ CAUTION: Thread locking compound may irritate sensitive skin. Read warning label on container before use.
- I. Unless otherwise specified, tighten all nuts and bolts to the standard torque specifications shown in the table at end of instruction. USE A TORQUE WRENCH for accurate measurements.
- J. Do not weld anything to these components, and do not weld any of these components to the vehicle unless specifically stated in the instructions. Welding on a vehicle creates an electrical charge throughout the body and frame. Disconnect the vehicle's battery prior to any welding. Place welding ground clamps as near as possible to the weld. Never use a vehicle suspension component as a welding ground point.
- K. It is extremely important to replace coil springs, axle flanges, and drive shaft/pinion relationships as original. Be sure to mark left/right, front/rear, and indexing of mating parts before disassembly. A paint marker or light colored nail polish is handy for this.
- L. Suspension components that use rubber or urethane bushings should be tightened with the vehicle at normal ride height unless otherwise specified. This will prevent premature failure of the bushing and maintain ride comfort.
- M. Some of the service procedures require the use of special tools designed for specific procedures. If you do not know how to safely use any of these tools, or do not have them, stop the project and consult a qualified mechanic. See "Tools and Supplies" on next page of this manual
- N. The required installation time for this system is approximately 4 to 5 hours for two people. Check off the box (☐) at the beginning of each step when you finish it. Then when you stop during the installation, it will be easier to find where you need to continue from.
- O. Important information for the end user is contained in the consumer/installer information pack. If you are installing this system for someone else, place the information pack on the driver's seat. Please include the installation instructions when you finish.
- P. The lifespan of Rancho products depends on many factors. Improper use, abuse or harsh use in general may compromise the integrity of the suspension system and significantly reduce its lifespan. The suspension system is also subject to wear over time. Have the suspension system regularly inspected and maintained by qualified mechanics. If the inspection reveals any damage or excessive wear, no matter how slight, immediately replace or repair the component. The suspension system must be regularly maintained in order to optimize its safe and efficient use. The more severe the conditions under which the suspension system is operated, the more often it must be inspected and maintained.
- Q. If any component breaks or bends, contact your local Rancho dealer or Rancho for replacement parts or, contact the Rancho Technical Department at 1-734-384-7804.

Thank you for purchasing the best suspension system available. For the best installed system, follow these instructions. If you do not have the tools or are unsure of your abilities, have this system installed by a certified technician. **RANCHO IS NOT RESPONSIBLE FOR DAMAGE OR FAILURE RESULTING FROM AN IMPROPER INSTALLATION**

**The driver of this suspension system recognizes and agrees that there are risks inherent in driving a vehicle with a lifted suspension system, including but not limited to the risk that you could be involved in an accident that would not occur in an unmodified vehicle. By his/her purchase and use of this suspension system, the user expressly, voluntarily and knowingly accepts and assumes these risks, and agrees to hold Tenneco, Inc. and its related companies harmless to the fullest extent permitted by law against any resulting damages.**

## SPECIFICATIONS & REQUIREMENTS

### Required Components and Modifications (MUST BE PURCHASED SEPARATELY)

#### Transmission Cross Member:

The correct Rancho transmission cross member must be purchased and installed with this kit

Model Year	Kit Number
2016 - 2012	RS886102
2011 - 2007	RS886101

#### Shock Absorbers:

New Rancho shock absorbers must be used with this kit, and must be purchased separately

Do not reuse OE shock absorbers

**⚠️ WARNING** Use of the wrong shock absorbers can cause damage to vehicle without the damage being visible to you, resulting in loss of vehicle control and an accident

#### Required Rancho Shock Absorbers

Front	Rear
RS999331	RS999332
RS7331	RS7330
RS55331	RS55332
RS5331	RS5332

#### Exhaust Clearance Issue:

##### 2012 - Newer models equipped with 3.6l V6 engine:

Because of clearance issues between the exhaust and front drive shaft, one of the following modification must be installed:

- **Preferred Method** -Replacement front drive shaft (see below for recommended replacement)
- Rancho Exhaust Modification Kit RS720003

### Wheels and Tires

This suspension system was developed using the following tire & wheel combination:

Tire: BF Goodrich® Mud-Terrain™ T/A® KM-35 x 12.50 R17

Wheel: 17" x 9" wheel with 4.5" of backspacing.

Total backspacing 5.9"

Maximum total backspacing is 6.8". Before installing any other combination, consult your local tire and wheel specialist.

Compatible With OE Wheels	Development Tire Size (Actual)	Optional Tire Size <sup>2</sup> (Actual)	Wheel Size (Backspacing)
Yes <sup>1</sup>	35x12.5xR17 (34.8"x12.5")	37x12.5xR17 (36.3"x12.8")	17x9 (4.5")

<sup>1</sup> OE wheels compatible with stock size tires only.

<sup>2</sup> Fitment of the optional tire size may require trimming to provide proper clearance.

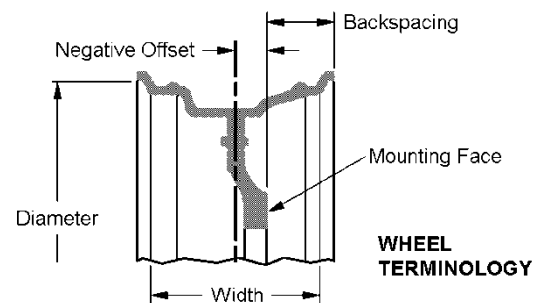

**WHEEL TERMINOLOGY**

### Recommended Components and Modifications (MUST BE PURCHASED SEPARATELY)

#### Drive Shafts:

During high articulation events, the front drive shaft may contact exhaust or transmission oil pan. A smaller diameter drive shaft is suggested for optimal performance.

Rancho recommends Powertrain Industries drives shafts:

Powertrain Industries, Garden Grove, CA.

1-800-798-4585.

<b>2016 — 2012 Models</b>	Part Number
Front drive shaft 2dr / 4dr:	3194-2125
Rear drive shaft 2dr:	3194-0475
Rear drive shaft 4dr	3194-2550
<b>2011 — 2007 Models</b>	Part Number
Front drive shaft 2dr / 4dr	3194-1925
Rear drive shaft 2dr	3194-2750
Rear drive shaft 2dr	3194-0725

#### Front Coil Spacer RS70082

If you have a winch mounted to the front bumper, use 3/4" spring spacer RS70082 to compensate for the additional weight.

#### Front Quick Disconnect Sway Bar Links RS6756B

Optional for non-Rubicon models for maximum articulation off road

### Tools and Supplies (BECAUSE OF VEHICLE VARIATIONS, THIS MAY NOT BE A COMPLETE LIST)

Jeep Service Manual	Die Grinder	Penetrating Lube (to aid removal of corroded and frozen hardware)
Torque Wrench (250 FT-LB capacity)	Right Angle Drill Motor	File
Hammer	Drill Bits – 3/8, 13/32, 31/64, 1/2, 45/64, 1	Hydraulic Floor Jack
1/2" Drive Ratchet and Sockets	Wire Brush (to clean mounting surfaces)	Heavy Duty Jack stands
Combination Wrenches	Red Loctite	Wheel Chocks (Wooden Blocks)
3/8-16 Tap	Grease or Anti-Seize	<b>Safety Glasses-</b>
Reciprocating Saw	Silicon Lubricant	Wear safety glasses at all times

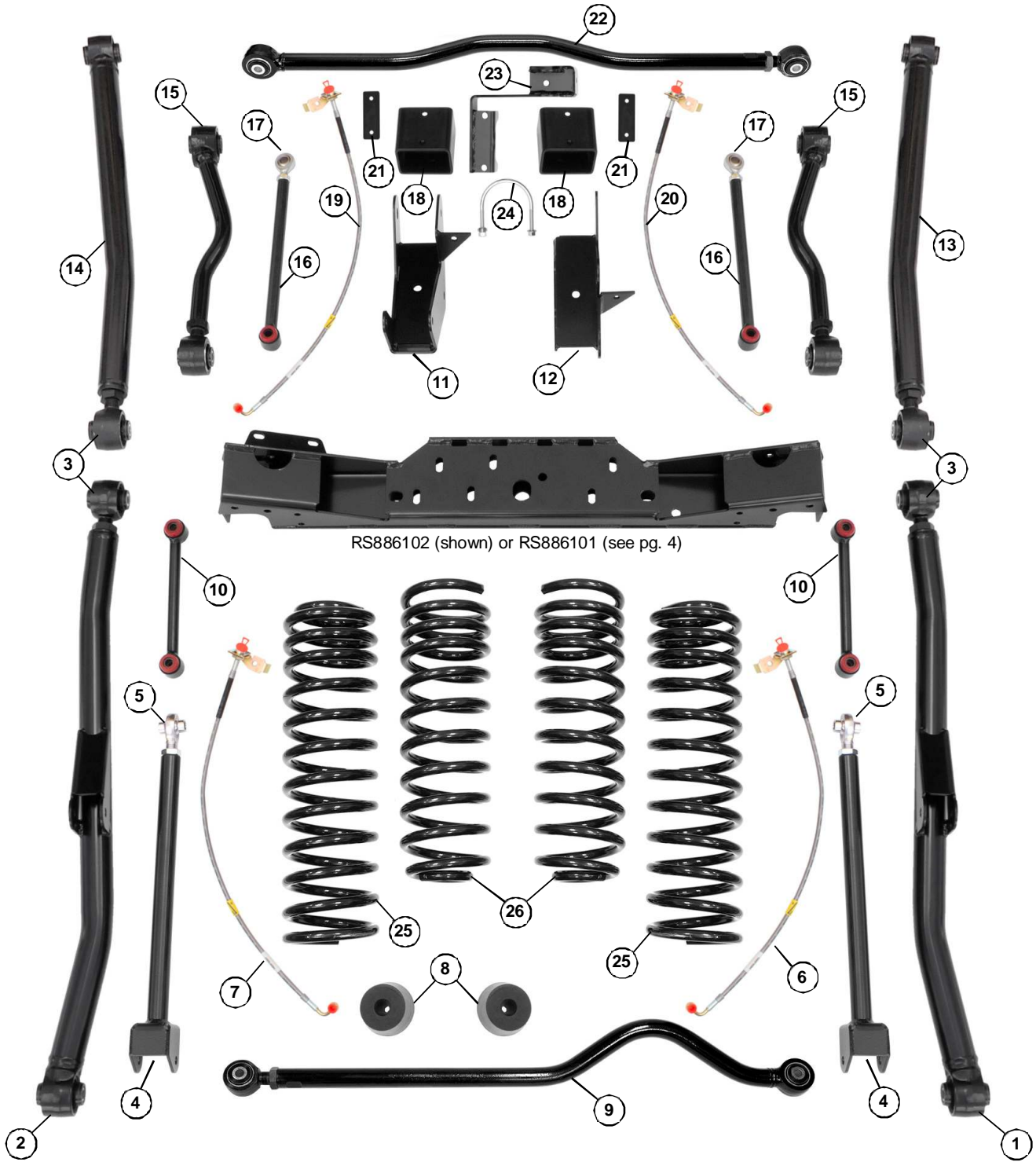

## Parts List

ITEM	PART #	DESCRIPTION	QTY
	<b>RS66115B-1</b>	<b>Box 1</b>	<b>1</b>
1	RS881021B	Lower Control Arm - Front Left	1
2	RS881022B	Lower Control Arm - Front Right	1
3	RS881014	Rod End – Lower Control Arms	2
	RS860588	Sub Assy, Control Arm	1
	RS42702	Thread Lock	1
	RS770043	HHCS, M14-X2.00X100	2
	RS7877	Nut, M14-2.00 Top Lock	2
	RS770109	Washer, M14	4
4	RS176448B	Caster Link	2
	RS860589	Sub Assy, Caster Link	1
5	RS602618	Rod End 3/4"	2
	RS770109	Washer, M14	4
	RS770129	HHCS, M14-2.00X80	2
	RS770070	Jam Nut, 3/4-16	2
	RS7877	Nut, M14-2.00 Top Lock	2
	RS860829	Sub Assy, Fuel Tank Skid	1
	RS770009	HHCS, M10-1.25X25	2
	RS770141	Nut, M10-1.25 Top Lock	2
	RS770064	Washer, M10	4
6	RS170110	Brake Line, Front Left	1
7	RS170113	Brake Line, Front Right	1
8	RS176443	Front Bumpstop Spacer	2
	RS860710	Sub Assy. Front Bumpstop Spacer	1
	RS7713	HHTS, 3/8-16 X 1.5	2
9	RS881001B	Front Track Bar	1
10	RS176779	Sway Bar End Link- Front	2
	RS860412	Sub Assy, Sway Bar End Link- Front	1
	RS448	Sleeve - 3/4 X 1/2 X 1.450	4
	RS545	Bushing, Hour Glass	4
	RS77035	HHCS, M12-1.75X70	2
	RS7807	Nut, M12-1.75 Nylock	2
	RS7723	Washer, 1/2 SAE	2
	RS7719	Washer, 1/2 USS	4
	RS89115	Instructions	1
	RS94180	Information Pack	1
	RS94177	Rollover Warning	1
	RS94119	Consumer/Warranty Information	1
	RS780281	Rancho Decal	1
	R-RM0082-1112	Warranty Tag	1
	<b>RS66115B-2</b>	<b>Box 2</b>	<b>1</b>
11	RS176466B	LCR Bracket - Driver Side	1
12	RS176467B	LCR Bracket - Passenger Side	1
	RS860591	Sub Assy, Drvr LCR Bracket	1
	RS770009	HHCS, M10-1.25X25	1
	RS770141	Nut, M10-1.25 Top Lock	1
	RS770064	Washer, M10	2
	RS770021	HHCS, M12-1.75X100	2
	RS7911	Nut, M12-1.75 Top Lock	2
	RS7915	Washer, M12	2
	RS7719	Washer, 1/2 USS	2
	RS420069	Crush Sleeve, 2.65"	1
	RS420071	Crush Sleeve, 2.9"	1

ITEM	PART #	DESCRIPTION	QTY
	RS860590	Sub Assy, Pass LCR Bracket	1
	RS176474	Nut Bracket, 1/2-13, 5.5"	1
	RS176137	Nut Bracket, 1/2-13, 4.0"	1
	RS7884	HHCS, 1/2-13 X 1.25	3
	RS7723	Washer, 1/2 SAE	4
	RS770009	HHCS, M10-1.25X25	1
	RS770141	Nut, M10-1.25 Top Lock	1
	RS770064	Washer, M10	2
	RS78361	Nut, 1/2-13 Top Lock	1
13	RS881023BL	Lower Control Arm - Left Rear	1
14	RS881023BR	Lower Control Arm - Right Rear	1
3	RS881014	Rod End – Lower Control Arms	2
	RS860588	Sub Assy, Control Arm	1
	RS42702	Thread Lock	1
	RS770043	HHCS, M14-X2.00X100	2
	RS7877	Nut, M14-2.00 Top Lock	2
	RS770109	Washer, M14	4
15	RS881004B	Upper Control Arm - Rear	2
16	RS176449B	Rear Swaybar End Link	2
	RS860592	Sub Assy, Rear Swaybar End Link	1
	RS7915	Washer, M12	4
	RS770160	BHCS, M12-1.75X45	2
	RS7719	Washer, 1/2 USS	2
17	RS602611	Spherical Rod End	2
	RS603111	Jam Nut, 5/8-18	2
	RS545	Bushing, Hour Glass	2
	RS448	Sleeve 3/4 X 1/2 X 1.45	2
	RS1755	Sleeve 5/8 X .527 X .68	2
	RS7911	Nut, M12-1.75 Top Lock	2
18	RS176478B	Rear Bump Stop Spacer 3"	2
	RS860830	Sub Assy, Rear Bump Stop	1
	RS770127	HHCS, M8-1.25X20	4
	RS770128	Washer, M8	8
	RS603112	Nut, M8-1.25 Nylock	4
19	RS170110	Brake Line, Rear Right (& Front Left)	1
20	RS170113	Brake Line, Rear Left (& Front Right)	1
	RS860711	Sub Assy, Rear Brake Line Bracket	1
21	RS176442	Rear Brake Line Bracket	2
	RS603615	HHCS, 1/4-20 X .75	2
	RS7907	Nut, 1/4-20 Top Lock	2
	RS77841	Washer 1/4 SAE	4
22	RS881006B	Rear Track Bar	1
23	RS176655B	Rear Track Bar Axle Bracket	1
	RS860713	Rear Track Bar Hardware Kit	1
24	RS7421	U-Bolt 3/8-16 X 3.5 X 4.20	1
	RS7604	Nut, 3/8-16 Nylock	2
	RS603508	Washer, 3/8 SAE	2
	RS770009	HHCS, M10-1.25X25	2
	RS770141	Nut, M10-1.25 Top Lock	2
	RS770064	Washer, M10	4
	RS770250	HHCS, M14-1.50X80	1
	RS770251	Nut, M14-1.50 Nylock	2
	RS770109	Washer, M14	3
	RS481	Sleeve 1.00 X .565 X 1.55	1
	<b>RS66115B-3</b>	<b>Box 3</b>	<b>1</b>
25	RS826B	Front Dual Rate Coil	2
26	RS827B	Rear Dual Rate Coil	2

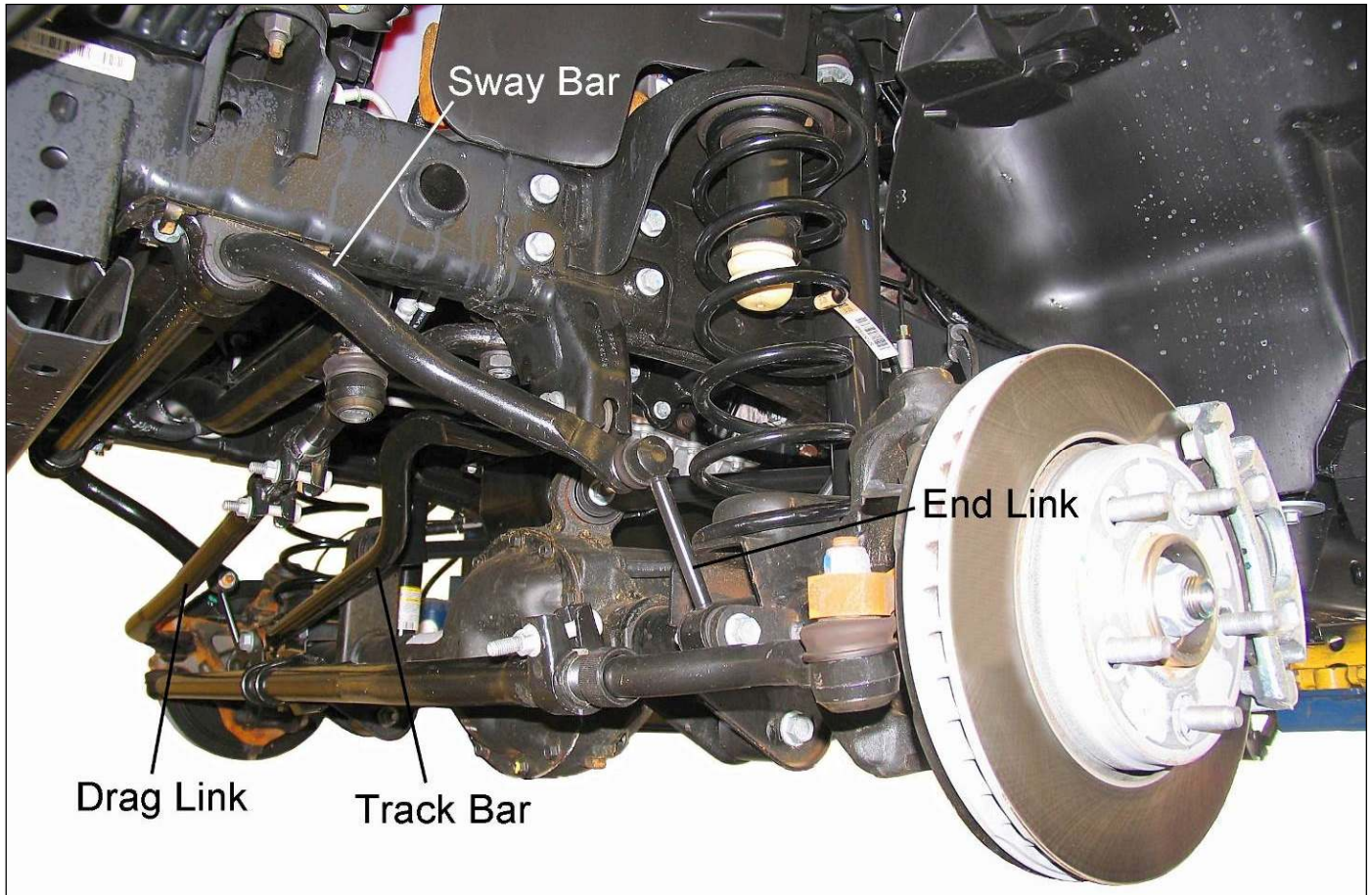

Illustration 1

## FRONT SUSPENSION

### SHOCK ABSORBER & COIL SPRING REMOVAL

- 1)  Park vehicle on a level surface. Set the parking brake and chock rear wheels. Disconnect the negative ground cable from the battery.
- 2)  Measure and record the distance from the center of each wheel to the top of the fender opening. Record in Illustration 2.
- 3)  Remove the track bar to frame bracket nut and bolt. See Illustration 1.

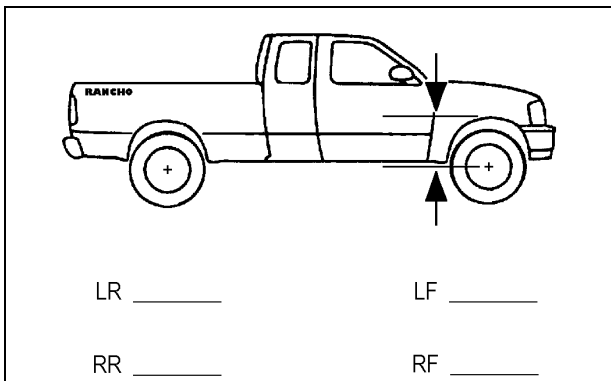

Illustration 2

### TRANSMISSION CROSS MEMBER REPLACEMENT

- 1)  Support the transmission with a jack.
- 2)  On earlier models, remove the transmission skid plate and skid plate cross brace (if equipped). See Illustration 3.

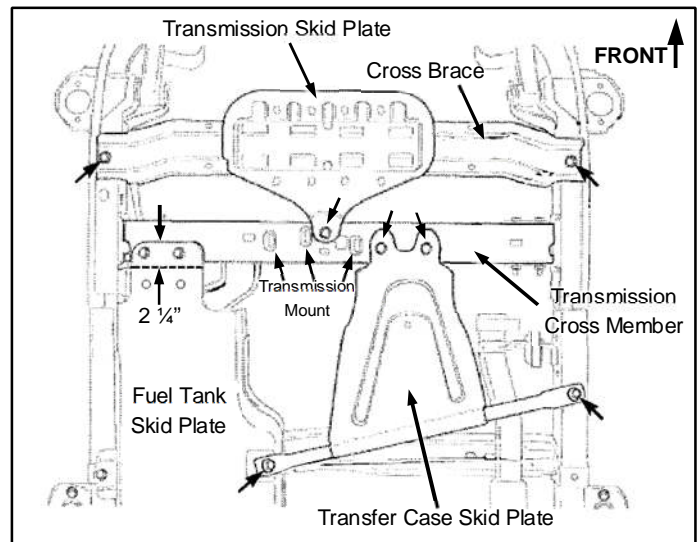

Illustration 3

- 4)  On later models remove the cross brace from the transmission cross member and frame.
- 5)  Cut 2 1/4 inches off the front of the fuel tank skid plate. See Illustration 3.
- 6)  Remove nuts holding transmission mount to cross member.
- 7)  Remove the cross member to frame bolts. Remove the cross member.
- 8)  Insert new cross member RS176460B (earlier models) or RS176648B (later models) into frame brackets. Attach cross member to frame with the original hardware. Center and torque to 90 ft-lbs. See Illustration 4.

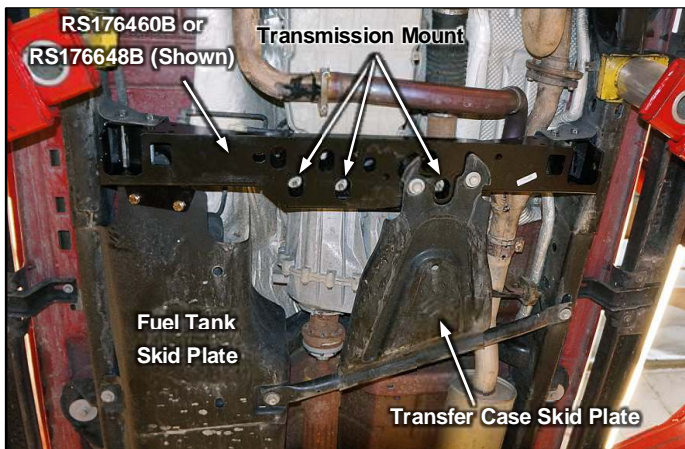

Illustration 4

- 9)  Attach transmission mount to cross member with the original nuts. Torque to 30 ft-lbs
- 10)  Loosely attach fuel tank skid plate to cross member with the 10mm hardware from kit RS860829.
- 11)  Loosely attach transfer case skid plate with the original hardware.
- 12)  Do not reinstall transmission skid plate or cross brace.

#### SHOCK ABSORBER AND COIL SPRING REMOVAL

- 1)  Support front axle with jack.
- 2)  Remove the track bar to axle bracket bolt and flag nut and remove track bar.
- 3)  Remove the end links from sway bar and axle.
- 4)  Reference mark the drive shaft to the front pinion flange (at axle). Disconnect the drive shaft from the pinion flange. Support drive shaft with a tie wrap or wire.
- 5)  Remove the shock absorber upper nut, retainer, and bushing.

- 6)  Remove the shock absorber lower nut and bolt. Remove the front shock absorber.

- 7)  Repeat steps 5 and 6 for the other side.

DO NOT REUSE ORIGINAL SHOCK ABSORBERS.

- 8)  Remove bolts and separate the brake hoses from the frame rails. If necessary, disconnect any vent hoses and electrical wiring from the axle.

- 9)  Carefully lower the front axle and remove the coil springs. Push down on axle if necessary.

**CAUTION:** Do not allow the front axle to hang by any hoses or cables.

#### CONTROL ARM PREPARATION

- 1)  Thread jam nuts completely onto rod ends RS881014 and apply grease or anti-seize to rod end threads.

- 2)  Thread rod ends into lower control arms RS881021B. and RS88102B. Adjust rod ends until the mounting holes are 38.0 inches apart (center to center).

TIP: Measure from edge to edge of sleeve See Illustration 5.

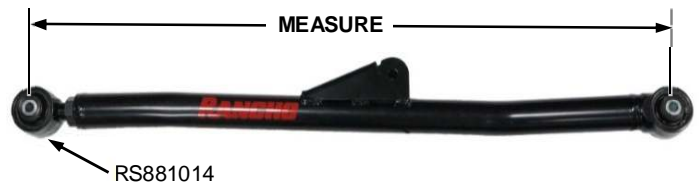

Illustration 5

- 3)  Thread jam nuts from hardware kit RS860589 completely onto rod ends RS602618 and apply grease or anti-seize to rod end threads.

- 4)  Thread rod ends into caster links RS176448B. Adjust rod end until the mounting holes are 20.4 (20-13/32) inches apart (center to center).

TIP: Control arms can be adjusted to achieve desired caster, driveline angles, axle center and clearance.

WARNING: Maximum exposed threads on control arms cannot exceed 1.188 (1-3/16) inches.

#### CONTROL ARM REPLACEMENT

- 1)  Remove the driver side upper control arm from the frame and axle brackets. See Illustration 6.

- 2)  Remove the driver side lower control arm from the frame and axle brackets.



4) □ Using a reciprocating saw and die grinder, cut off the lower suspension arm frame bracket even with the frame. See Illustration 7 and Illustration 8.

5) □ File or grind sharp edges and paint exposed metal. See Illustration 9 and Illustration 10.

NOTE: Do not tighten control arm hardware until the end of the installation procedure. The upper front axle mount must be tightened with vehicle on the ground at ride height.

6) □ Attach the non-adjustable side of the lower control arm R881021B to the driver side axle bracket with the original hardware. The bend of the arm goes to the inside to provide clearance for tire. See Illustration 11.

7) □ Attach the adjustable side of the lower control arm R881021B to the transmission cross member with the hardware from kit RS860588.

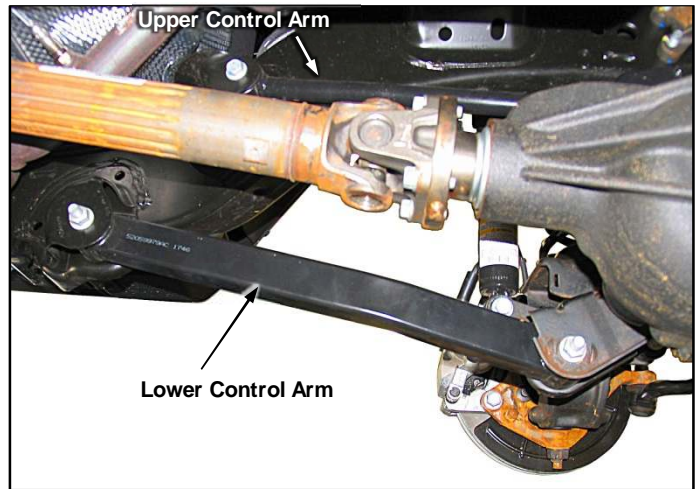

Illustration 6

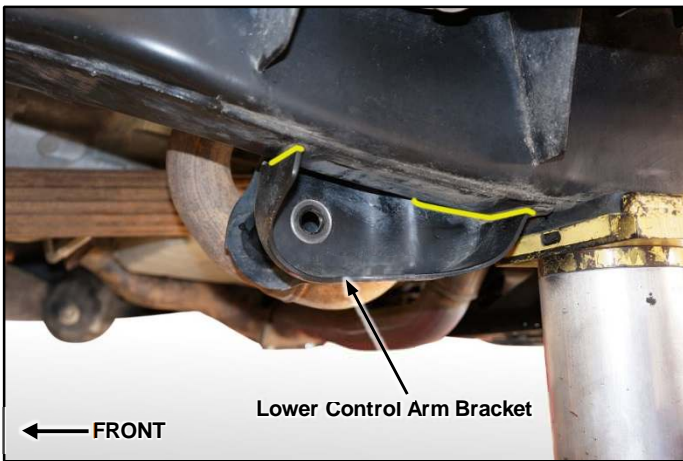

Illustration 7

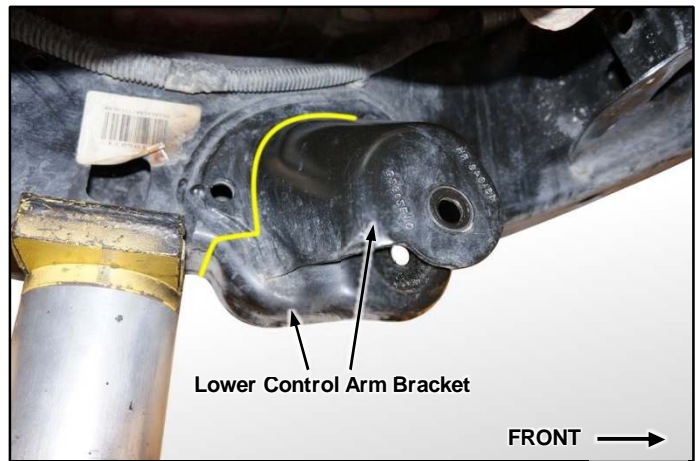

Illustration 8



Illustration 9

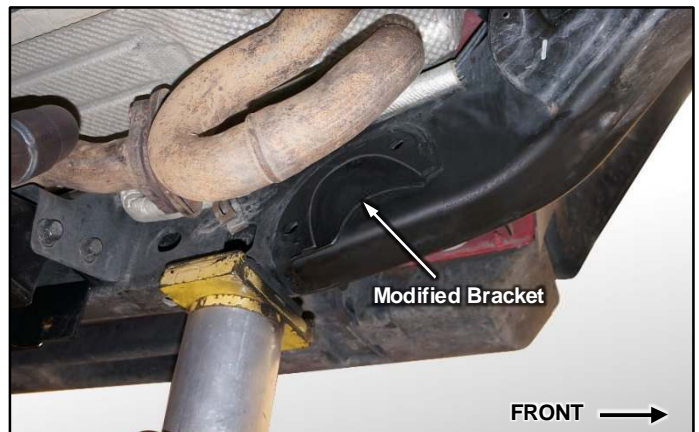

Illustration 10

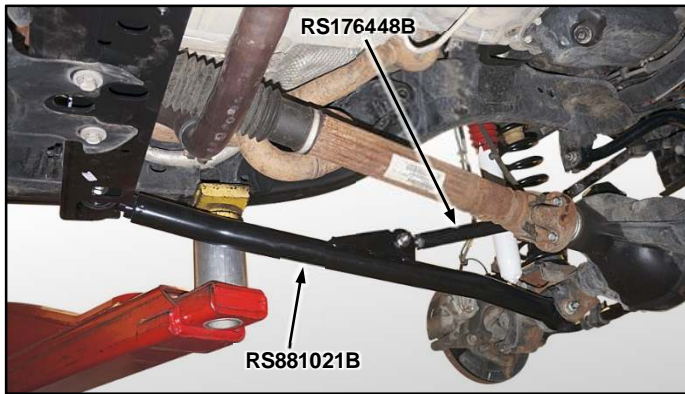

Illustration 11

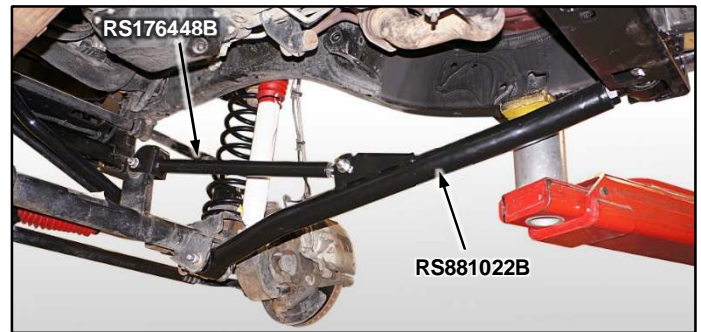

Illustration 12

8)  Remove the passenger side upper control arm from the frame and axle brackets.

**NOTE 2007 – 2011 models:** To disconnect the upper control arm from the passenger side frame bracket, the mounting bolt must be cutoff or the exhaust removed.

9)  Attach caster link assembly to the axle with the original hardware and to the lower control arm with the 14mm hardware from kit RS860589. See Illustration 11.

10)  Repeat steps 1-6 and step 8 for the passenger side. See Illustration 12.

11)  Torque lower control arm hardware at axle, cross member and caster link to 125 ft-lbs.

Do not tighten caster link to axle until vehicle is on ground at ride height.

12)  Torque jam nuts on lower control arms to 200 ft-lbs.

13)  Center caster link rod end in mounting bracket and torque jam nut to 150 ft-lbs. A 15mm wrench can be used to keep rod end from spinning.

**BUMP STOP SPACER, COIL SPRING & SHOCK ABSORBER INSTALLATION**

1)  Drill a 5/16" hole through the center of the coil spring axle pad to mount bump stop spacer RS176779. For ease of installation, tap the hole to 3/8-16. See Illustration 13.

2)  Install original rubber isolator on top of coil spring 826B. Place bump stop spacer RS176443 inside the coil spring.

3)  Lower axle if required and insert the spring assembly into the upper pocket and onto the axle pad. Align pig tail with groove in axle pad. See Illustration 13.

**CAUTION:** Do not allow the front axle to hang by any hoses or cables.

4)  Attach the bump stop spacer to the axle pad with the self-tapping screw from kit RS860710 and red Loctite. Torque to 20 lb-ft.

5)  Repeat steps 1 through 4 for the other side.

6)  Install retaining washer and bushing on NEW shock absorber, insert shock into upper mounting hole. Install bushing, washer and nut. Tighten nut until bushing swells larger than retaining wash (about 17 lb-ft). Repeat for other side.

7)  Raise front axle and attach shock lower mounts to axle brackets with the original hardware. Torque to 56 lb-ft.

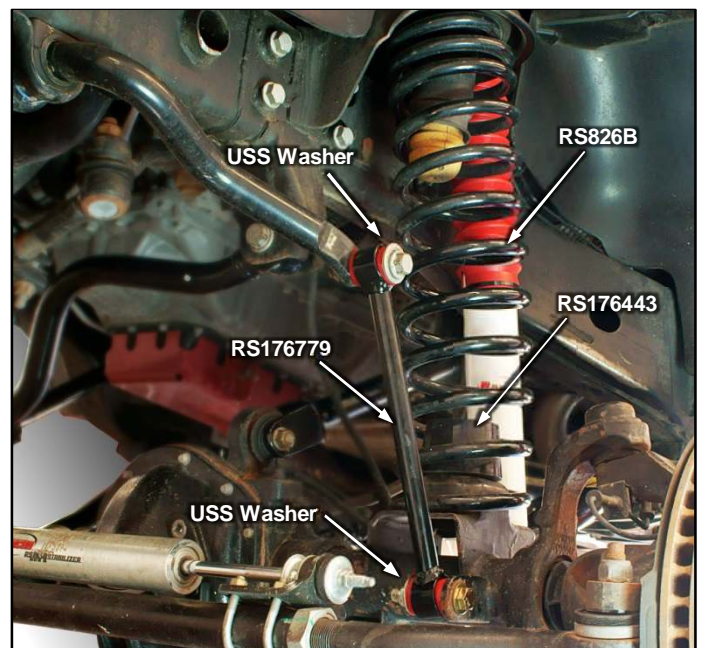

Illustration 13

8)  Attach the bump stop spacer to the axle pad with the self-tapping screw from kit RS860710 and red Loctite. Torque to 20 lb-ft.

9)  Repeat steps 1 through 4 for the other side.

11)  Install retaining washer and bushing on NEW shock absorber, insert shock into upper mounting hole. Install bushing, washer and nut. Tighten nut until bushing swells larger than retaining wash (about 17 lb-ft). Repeat for other side.

12)  Raise front axle and attach shock lower mounts to axle brackets with the original hardware. Torque to 56 lb-ft.

13)  Reattach drive shaft to pinion flange using OE hardware and blue Loctite. Torque to 81 lb-ft.

14)  Reattach vent hose and electrical wiring if necessary.

#### **SWAY BAR END LINK INSTALLATION.**

1)  Using a silicone spray, insert the bushings and sleeves from hardware kit RS860412 into new end links RS176779.

NOTE: Use a vise, arbor press, or C-clamp to install sleeves

2)  Attach end links to sway bar with the original bolts and large USS washers from hardware kit RS860412. See Illustration 13.

3)  Attach end links to axle brackets with the hardware from kit RS860412. Torque to 75 lb-ft.

#### **TRACK BAR INSTALLATION**

1)  Adjust length of new Rancho track bar RS881001B to 33.06" (33-1/16").

2)  Attach track bar to axle bracket using OE hardware and torque to 125 ft-lbs.

NOTE: Frame end of track bar will be attached after lowering vehicle to ground.

#### **BRAKE HOSE REPLACEMENT**

NOTE: To keep the brake bleeding process to just the front brakes, do not allow the brake fluid to drain completely from the master cylinder reservoir.

1)  Loosen then lightly re-tighten both ends of brake line before removing to ensure connections will move.

2)  Separate the driver side ABS line from the brake hose.

3)  Separate the driver side brake hose from the brake tube and frame rail. Plug tube to prevent brake fluid leakage.

4)  Remove the brake hose from the caliper. Discard copper washers.

5)  Attach left brake hose RS170110 to the caliper with the supplied banjo bolt and new copper washers Torque to 23 lb-ft.

6)  Attach left brake hose to the frame rail with the original bolt. Attach brake tube to hose. Torque brake tube fitting to 18 lb-ft. See Illustration 14.



Illustration 14

7)  Slide grommets on ABS wire to provide slack for full suspension/turning movement. Reattach ABS wires to brake lines.

8)  Check brake fluid level and repeat steps 1 through 7 to install right brake hose RS170113 on the passenger side.

9)  Bleed front brakes.

#### **LOWER VEHICLE**

1)  Install front wheels and lower vehicle to the ground. Tighten lug nuts to 80-110 lb-ft.

2)  Torque caster link at axle mount to 75 lb-ft.

3)  Attach track bar to frame mount using OE hardware

4)  Torque track bar bolts to 125 lb-ft. Torque jam nut to 150 lb-ft.

Note: If track bar does not align with bracket, have an assistant slowly turn steering wheel to align holes.

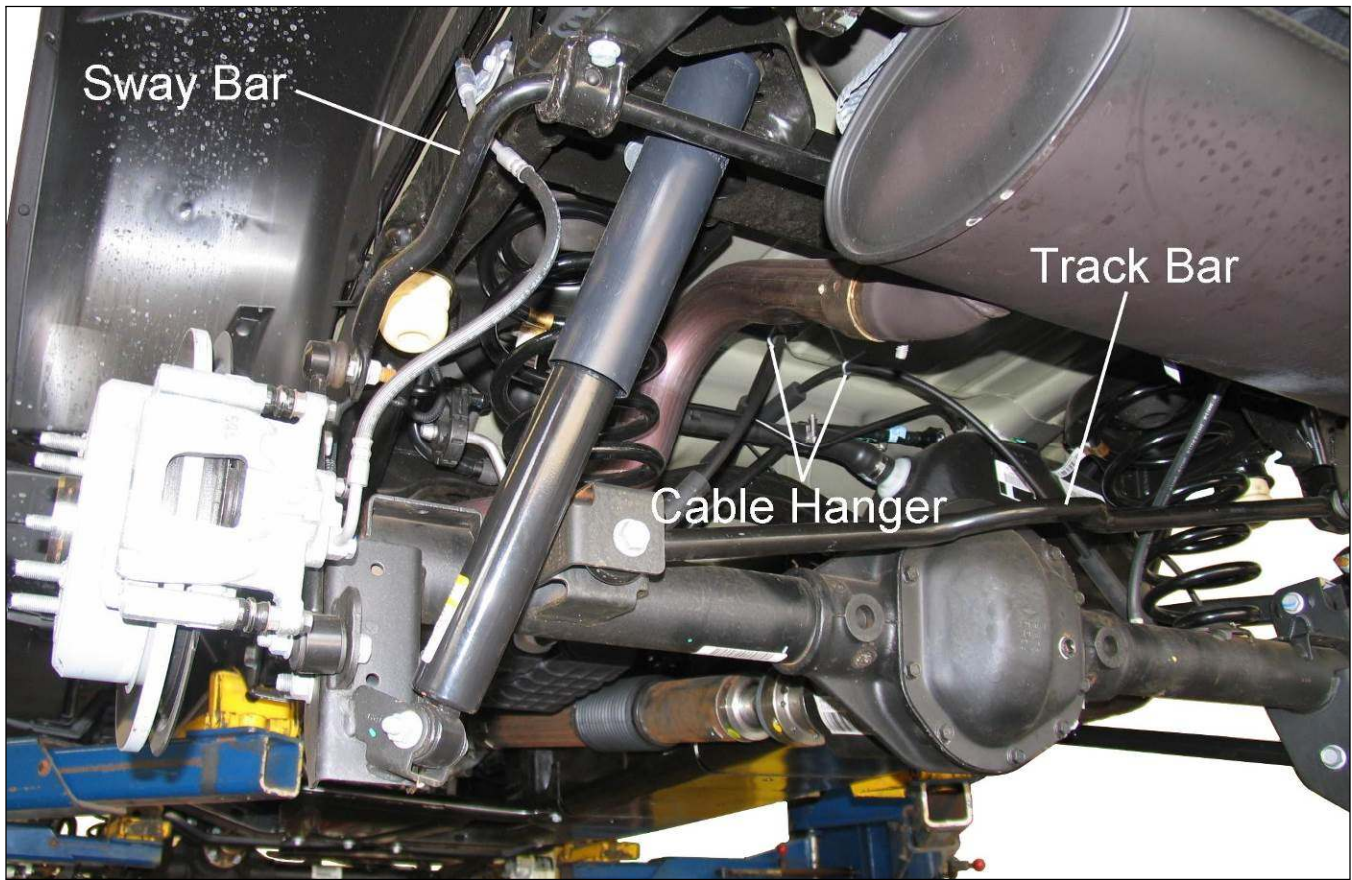

Illustration 15

## REAR SUSPENSION

### SHOCK ABSORBER & COIL SPRING REMOVAL

- 1)  Disconnect the track bar from the frame bracket. See Illustration 15.
- 2)  Chock front wheels. Raise the rear of the vehicle and support the frame with jack stands. Place stands 8 – 8 ½” forward of body mount bracket to allow clearance to install new control arm bracket. See Illustration 16.
- 3)  Remove the rear wheels.
- 4)  Support the rear axle with a floor jack.

NOTE: The axle may rotate or twist later in installation. Position jack so you can brace or support the pinion flange to keep it from rotating down, or strap axle to jack to prevent axle from rolling off jack.

- 5)  Remove the nuts or bolts from the brake parking cable hanger above the rear axle. Remove the hanger from the cables. See Illustration 15.
- 6)  Remove bolts and separate the brake hoses from the frame rails. Remove clips holding ABS wire to frame. If necessary, disconnect any vent hoses and electrical wiring from the axle. See Illustration 17.

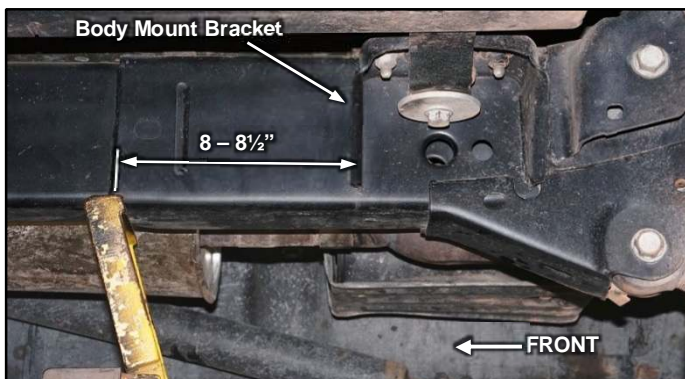

Illustration 16

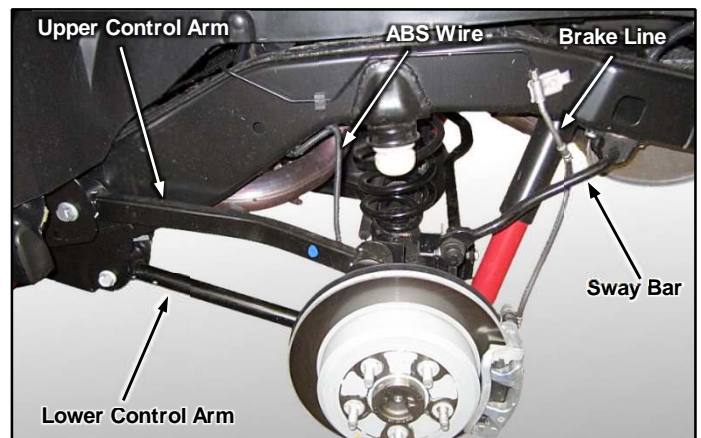

Illustration 17

7)  Remove the shock absorber upper mounting bolts. Remove the lower nut and bolt from the axle bracket. Remove the shock absorber. Repeat for other side.

8)  Remove the sway bar end links from the axle and sway bar.

9)  Carefully lower the rear axle until the coil springs are free from the upper mount seat. Remove the coil springs.

**CAUTION:** Do not allow the axle to hang by any hoses or cables.

#### **CONTROL ARM ASSEMBLY**

1)  Thread jam nuts completely onto rod ends RS881014 and apply grease or anti-seize to rod end threads.

2)  Thread rod ends into lower control arms RS881023BL and RS881023BR. Adjust rod end until the mounting holes are 30.4 (30-13/32) inches apart (center to center).

3)  Adjust upper control arms control arms 881004B, and until the mounting holes are 18.1 (18-3/32) inches apart (center to center).

TIP: Control arms can be adjusted to achieve desired driveline angels, axle center and clearance.

**WARNING:** Maximum exposed threads on control arms cannot exceed 1.188 (1-3/16) inches.

#### **CONTROL ARM BRACKET INSTALLATION**

1)  Remove both passenger and driver side bolt from body mount just forward of control arms. See Illustration 18.

2)  Remove the driver side lower control arm nut and bolt from the axle bracket. Remove the bolt and flag nut at the frame rail bracket. Remove the lower control arm. See Illustration 17.

3)  Remove the driver side upper control arm flag nut and bolt from the axle and frame rail brackets. Remove the upper control arm.

TIP: Axle mount uses a shorter bolt. Insert bolt in axle mount to keep separate.

4)  Cut off the entire driver side lower frame bracket even with the bottom of the frame rail. See Illustration 18 and Illustration 19.

5)  Use a small cutoff wheel and die grinder to slice into weld and remove forward portion of the bracket that is welded to the inside and outside of the frame under the body mount.

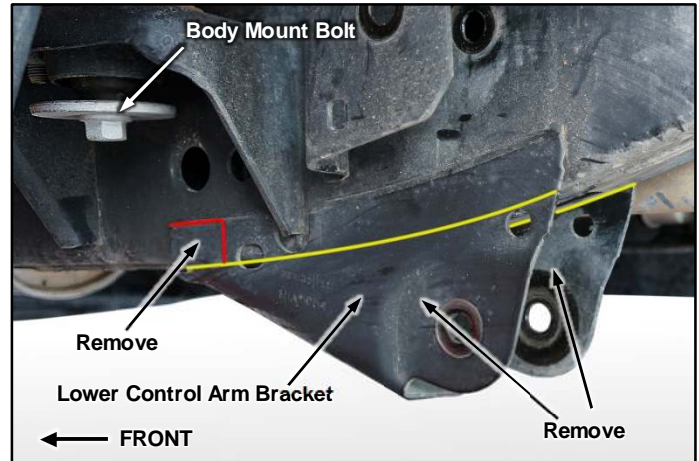

Illustration 18

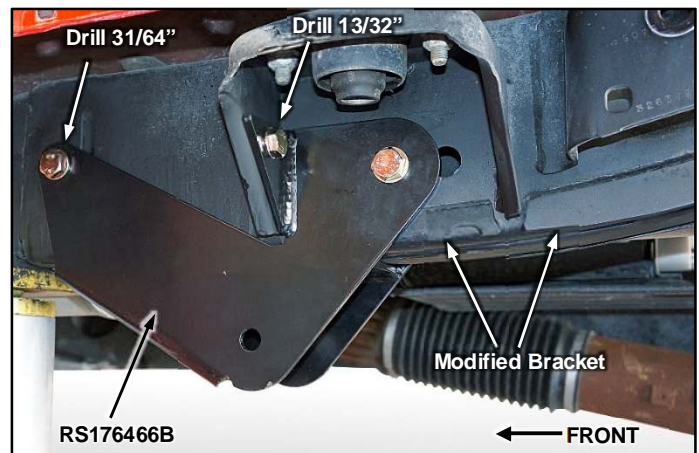

Illustration 19

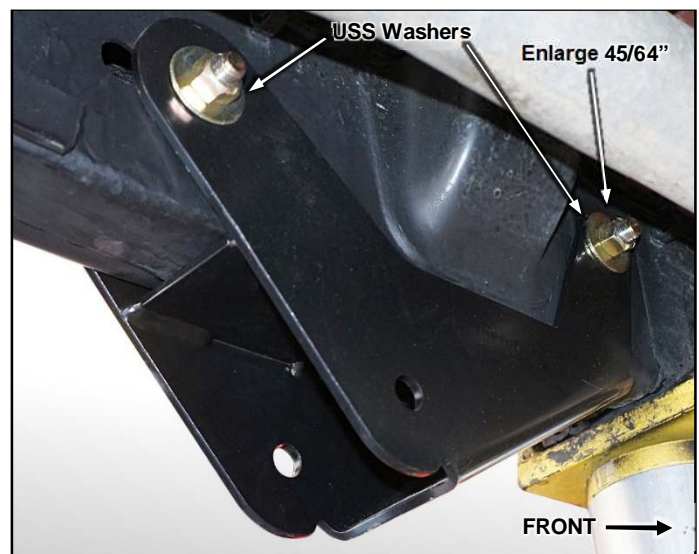

Illustration 20

- 6)  File or grind sharp edges and paint exposed metal
- 7)  Place left suspension arm bracket RS176466B on the driver side frame rail. Push bracket against frame and body mount. See Illustration 19.

NOTE: Bracket must sit flush against body mount, sides and bottom of frame. Some additional grinding may be required.

- 8)  Using the bracket as a template, mark the mounting hole locations on the frame (front hole only) and body mount. Remove the bracket.
- 9)  Drill a 13/32 hole through the body mount and a 31/64 hole through the inside and outside of the frame rail. Enlarge the inside hole to 45/64. See Illustration 19 and Illustration 20.
- 10)  Loosely attach left control arm bracket RS176466B to the driver side body mount bracket using the 10mm hardware from kit RS86059.,
- 11)  Attach the front of the bracket to the frame rail using the 12mm hardware and shorter sleeve from kit RS860591. Install the larger USS washer against the larger inside facing hole of the bracket.
- 12)  Attach the rear of the bracket to the frame rail using the 12mm hardware and longer sleeve from kit RS860591. Install the larger USS washers against the larger inside facing hole of the bracket.
- 13) Torque 12mm hardware to 75 ft-lbs, and the 10mm hardware to 45 ft-lbs.
- 14)  Attach adjustable end of lower suspension arm RS881023BL to driver side bracket RS176466B, using the 14mm hardware from kit RS860588. See Illustration 21.

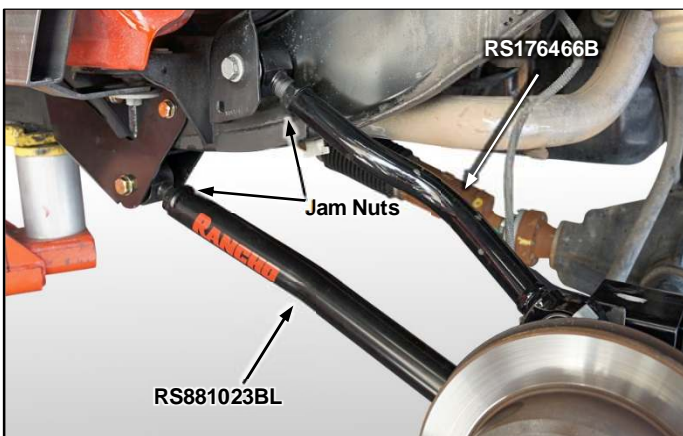

Illustration 21

- 15) Attach the non-adjustable end of lower suspension arm RS176466B to the axle bracket using OE hardware.

- 16)  Attach the adjustable end of the upper control arm RS881004B to the frame bracket with the original bolt and flag nut. The bend of the arm goes to the inside to provide clearance for tire. See Illustration 21.

NOTE: Make sure other end of upper control arm is above the axle to allow installation in axle bracket.

WARNING: The axle may rotate or twist in the next step. Brace the axle under the pinion flange or strap to jack to prevent axle from rolling off jack.

- 17)  Remove bolt and flag nut holding OE PASSENGER SIDE upper control arm to frame bracket.
- 18)  Attach NEW DRIVER SIDE upper control arm to axle bracket using OE bolt and flag nut.
- 19)  Remove the OE PASSENGER SIDE upper control arm flag nut and bolt from the axle bracket. Remove the upper control arm.
- 20)  Remove the OE PASSENGER SIDE lower control arm nut and bolt from the axle bracket. Remove the bolt and flag nut at the frame rail bracket. Remove the lower control arm.
- 21)  Using a die grinder and reciprocating saw, cut off the passenger side frame bracket as shown in Illustration 22 and Illustration 24.

CAUTION: The fuel tank is located next to the passenger side frame rail. Protect the tank by inserting a metal plate while cutting. Do not use a torch or plasma cutter.

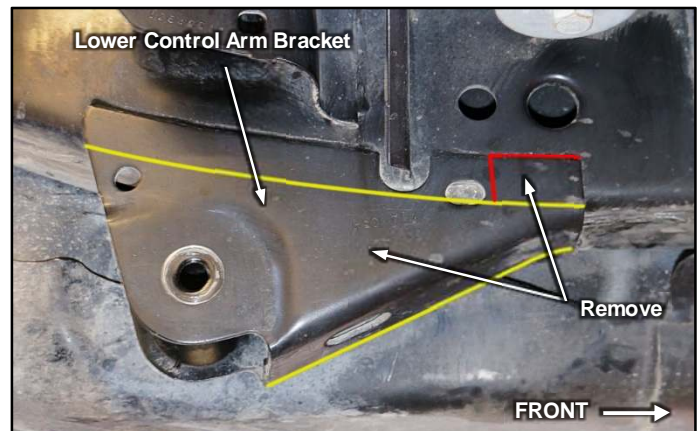

Illustration 22

- 22)  Use a small cutoff wheel and die grinder to slice into weld and remove the forward portion of the bracket that is welded to the outside of the frame under the body mount.
- 23)  Loosen all fuel tank skid plate bolts. Push skid plate inward. Remove the bolt from the skid plate bracket just forward of the body mount.

25) □ Place right suspension arm bracket RS176467B on the driver side frame rail. Push bracket against frame and body mount. Bracket will slide between frame and skid plate bracket.

NOTE: Bracket must sit flush against body mount, sides and bottom of frame. Some additional grinding may be required.

26) On some vehicles it will be necessary to cut out some of the fuel tank skid plate bracket. Use a cutoff wheel to make two cuts and bend off tab with pliers or vice grips, or adjustable crescent wrench. Alternatively, both edges of the bracket can be cut off. See Illustration 23.

**DO NOT CUT OR DAMAGE FUEL TANK**

27) □ File or grind sharp edges and paint exposed metal.

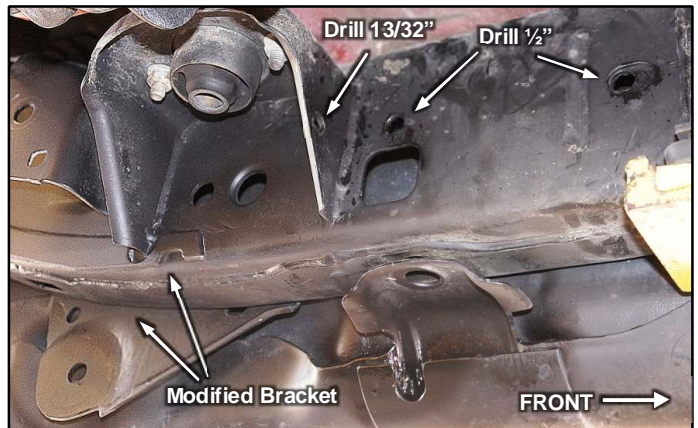

Illustration 24



Illustration 23

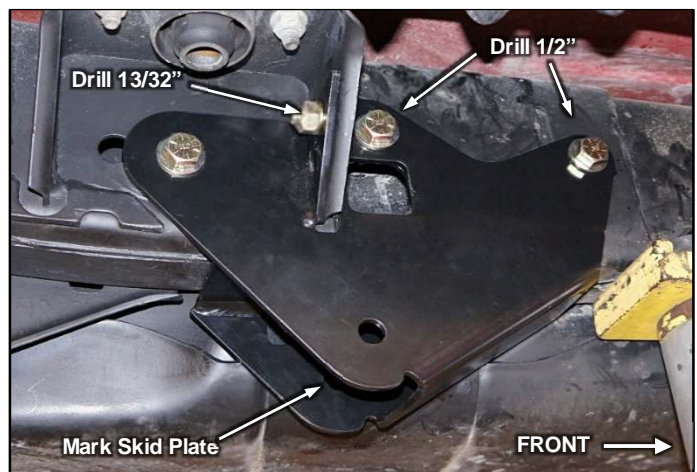

Illustration 25

28) □ Using bracket RS176476B as a template, mark the mounting hole locations on the frame and body mount. Mark the relief hole location on the skid plate for the suspension arm nut and bolt. Remove bracket. See Illustration 24, Illustration 25 and Illustration 26.

29) □ Drill two 1/2" holes into the frame, and one 13/32" hole through the body mount. Drill only through the outside of the frame. See Illustration 24.

30) □ Drill a 1" hole into the fuel tank skid plate at the marked locations. The skid plate bracket comes behind the skid plate and forms a small channel or void. See Illustration 26.

**DRILL THROUGH THE OUTER SKID PLATE ONLY, DO NOT DRILL THROUGH THE BRACKET!**

31) □ Use a cutoff wheel to trim from the hole to the top edge of the skid plate. Use a file, rotary file, or sanding roll to smooth and deburr cut. Paint exposed metal. See Illustration 26.

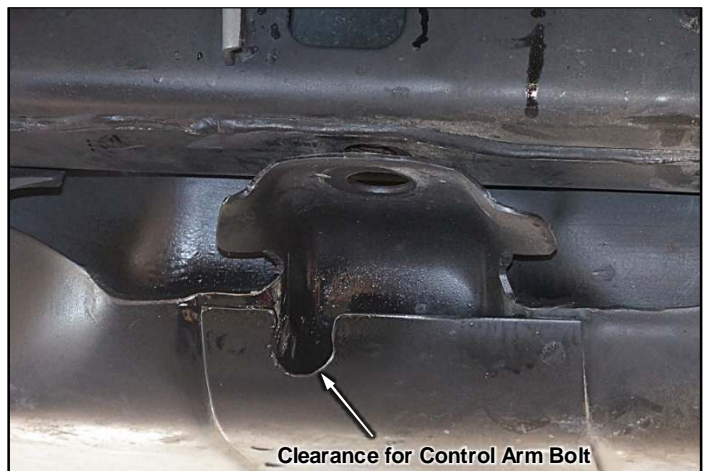

Illustration 26

32)  Use a hammer to bend the area of the cutout in slightly. File or grind sharp edges and paint exposed metal.

33)  Loosely attach right control arm bracket RS176467B to the passenger side body mount bracket using the 10mm hardware from kit RS860590. See Illustration 25.

34)  Loosely attach right control arm bracket the frame rail with ½" hardware and nut brackets from kit RS860590. Use the longer nut bracket for the front hole and the shorter nut bracket for the rear hole. Use thread lock on nut brackets.

35)  Reattach fuel tank skid plate mount with OE bolt. Torque ½" hardware to 65 ft-lbs, and the 10mm hardware to 45 ft-lbs.

36)  Reinstall bolts for body mounts (passenger and driver side) and torque to 80 ft-lbs.

37)  Torque all OE fuel tank and transmission skid plate bolts to 73 ft-lbs. Torque 10mm hardware holding fuel tank skid plate to transmission cross member to 45 ft-lbs.

38)  Attach adjustable end of lower suspension arm RS881023BR to passenger side bracket RS176467B, using the 14mm hardware from kit RS860588. Refer back to Illustration 21.

39)  Attach the non-adjustable end of lower suspension arm RS881023BR to the axle bracket using OE hardware.

40)  Torque all 8 control arm bolts to 125 ft-lbs. Torque jam nuts to 200 ft-lbs.

#### REAR TRACK BAR AXLE BRACKET INSTALLATION.

1)  Remove track bar from axle bracket. See Illustration 15.

2)  Place track bar bracket RS176655B over the original rear axle bracket.

3)  Insert the sleeve RS481 from kit RS860713 and loosely attach track bar bracket RS176655B to the rear axle bracket with supplied M14-1.50 X 80mm hardware through bottom OE hole. See Illustration 27 and Illustration 28.

4)  Attach bracket RS176655B to the rear axle tube using the U-Bolt and 3/8 washer and nylock nuts from hardware kit RS860713. At this time just snug down attached hardware. Do not torque down.

5)  Use a clamp to hold bracket RS176655B snug to axle bracket. Using RS176655B as template, center punch and drill 3/8" holes on top and side of frame bracket.

6)  Install M10-1.25 X 25mm bolts from hardware kit RS860713 in drilled holes. Torque M10 hardware to 40 lb-ft., 3/8" U-bolt to 30 lb-ft., then M14 hardware to 125 lb-ft.

7)  Adjusts length of new Rancho track bar RS881006B to 40.13" (40-1/8"). Attach track bar to bracket RS176655B using OE bolt and M14 washer and nylock nut. Torque bolt to 125 ft-lbs.

NOTE: Frame end of track bar will be attached after lowering vehicle to ground.

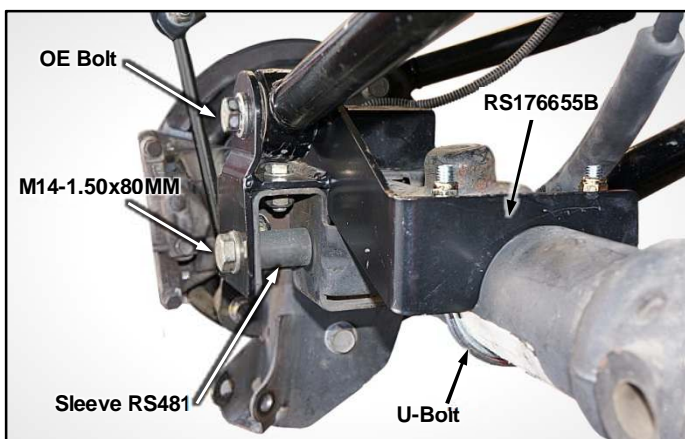

Illustration 27

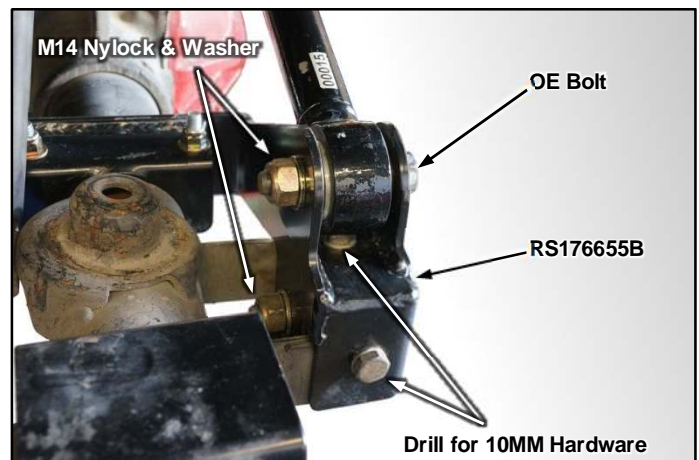

Illustration 28



### COIL SPRING & SHOCK ABSORBER INSTALLATION

- 1)  Place OE isolators on top of new coil springs RS827B.
- 2)  Set coil onto the axle pad. Raise the axle until the coil springs and isolators seat on the upper mounts. Move coils back and forth to seat on upper mounts when raising axle. Align the last wrap of the coil so it hooks around the front of the upper mount. See Illustration 29.

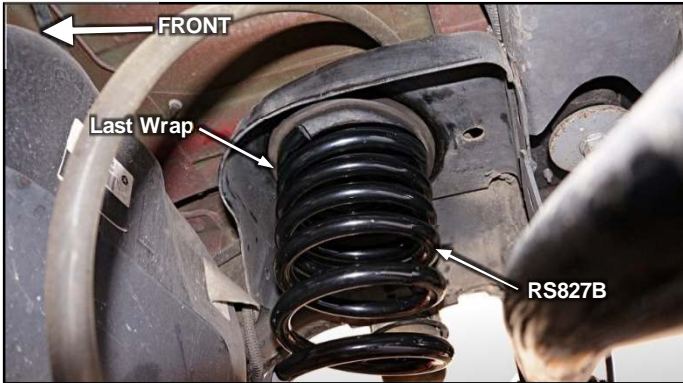

Illustration 29

**NOTE:** When installing coil springs, make sure that the rubber isolator is positioned in the upper mount and the small egg-shaped pig tail end is at the bottom.

- 3)  Attach new Rancho rear shocks to the upper mounting brackets with the original bolts. Tighten bolts to 23 lb-ft.
- 4)  Attach shocks to the axle brackets with the original hardware. Torque the shock absorber lower mounting bolts to 56 lb-ft.

### BUMP STOP BRACKET INSTALLATION

- 1)  Using the original holes on the axle pad, attach bump stop bracket RS176478B to the axle with the 8mm hardware from kit RS860830. Tighten nuts and bolts to 23 ft. lbs. See Illustration 30.
- 2)  Repeat for other side.

### SWAY BAR END LINK INSTALLATION

- 1)  Install jam nut from kit RS860592 on rod end RS602611. Apply grease or ant-size to threads and insert rod end into end link RS176449B.
- 2)  Press short sleeve RS1755 into rod end.
- 3)  Lubricate a bushing and long sleeve from kit RS860592 with silicone spray. Press bushing then sleeve into end link assembly.

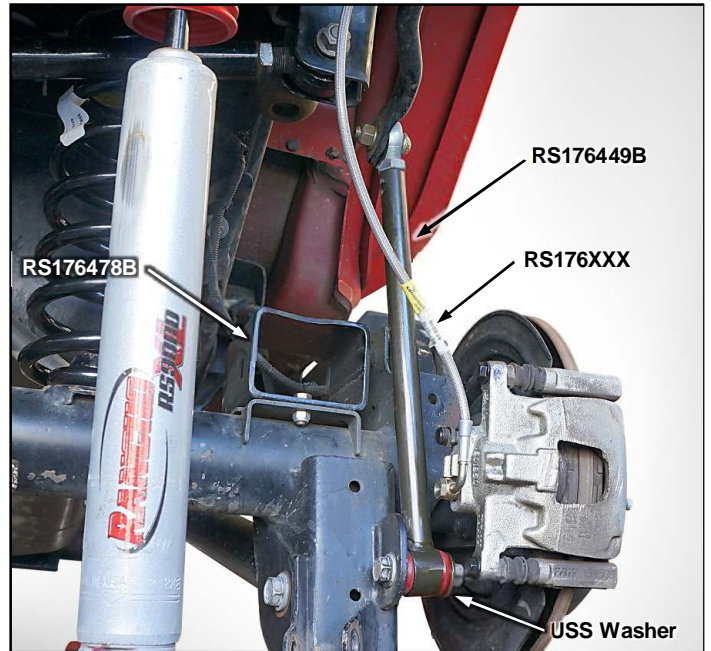

Illustration 30

- 4)  Attach end link assembly to axle bracket with OE hardware, and sway bar with the 12mm button head hardware from kit RS860592. See Illustration 30. Insert the button head bolt from the outside. Torque hardware to 75 ft-lbs.
- 5)  Tighten jam nut to 75 ft-lbs.
- 6)  Repeat steps 1 through 5 for the other side.

### BRAKE HOSE REPLACEMENT

**NOTE:** To keep the brake bleeding process to just the rear brakes, do not allow the brake fluid to drain completely from the master cylinder reservoir.

- 1)  Loosen then lightly re-tighten both ends of brake hose before removing to ensure connections will move.
- 2)  Attach passenger side brake hose RS170110 to frame using OE hardware.
- 3)  Separate the passenger side brake hose from the brake tube. Attach brake tube fitting to new brake hose and snug.
- 4)  Remove the brake hose from the caliper. Discard copper washers.
- 5)  Attach right brake hose RS170110 to the caliper with the supplied banjo bolt and new copper washers. Torque banjo bolt to 23 lb-ft. See Illustration 30. Torque brake tube fitting to 18 lb-ft.

- 7)  Remove brake hose bracket from frame.
- 8)  Loosely attach brake line re-location bracket RS176442 to the outside of brake line bracket using 1/4" hardware from kit RS860711. See Illustration 31.

NOTE: One corner of re-location bracket is chamfered to allow it to fit against brake line bracket.



Illustration 31

- 9)  Carefully re-shape metal brake tube and attach brake line re-location bracket to frame using OE hardware. See Illustration 31. Torque OE and 1/4" hardware to 8 ft-lbs.

NOTE: Brake line bracket will sit above frame rail. Make sure metal brake tube sits in close against frame and body to allow maximum clearance with sway bar and tires.

- 10)  Check brake fluid level and repeat steps 1-8 for driver side with left brake line RS170113.
- 11)  Bleed rear brakes.

#### LOWER VEHICLE

- 1)  Install rear wheels and lower vehicle to the ground. Tighten lug nuts to 80-110 lb-ft.
- 2)  Attach rear track bar to frame bracket using OE hardware. Torque track bar hardware at frame and axle bracket to 125 lb-ft. Torque jam nut to 150 ft-lbs.
- 3)  Reconnect the battery ground cable.

### FINAL CHECKS & ADJUSTMENTS

- 1)  Turn the front wheels completely left then right. Verify adequate tire, wheel, brake hose and ABS wire clearance. Inspect steering and suspension for tightness and proper operation.
- 2)  With the suspension at maximum extension (full droop), inspect and rotate all axles and drive shafts. Check for binding and proper slip yoke insertion. The slip yoke should be inserted a minimum of one inch into the transfer case and/or transmission.
- 3)  Ensure that the vehicle brake system operates correctly. If new brake hoses were installed, verify that each hose allows for full suspension movement.
- 4)  Center steering wheel and axle.

Whenever track bar length is adjusted, the steering wheel must be centered to ensure that the ESP system operates correctly.

- Slowly drive vehicle 50-100 ft to settle suspension.
- If front axle needs to be centered, remove track bar at axle mount and adjust length by HALF the amount axle is off center.
- Reattach track bar and torque to 125 lb-ft. Torque Jam nut to 150 lb-ft
- To center the steering wheel, loosen drag link adjust sleeve clamp bolts and turn the drag link adjustment sleeve in desired direction. Adjustment sleeve bolts must face forward for good clearance. Torque clamp bolt bolts to 26 lb-ft. See Illustration 1.

- 5)  Readjust headlamps.
- 6)  Have vehicle Aligned to manufacturer's specifications.

#### Alignment Specifications

Caster	4.6°	± 1.0°
Camber (fixed angle)	-0.25°	± 0.63°
Toe-In (each wheel)	0.15°	± 0.15°
Thrust Angle	0	± 0.15°

- 7)  Park the vehicle on a level surface. Measure and record the distance from the center of each wheel to the top of the fender opening. Record these measurements in the space provided.

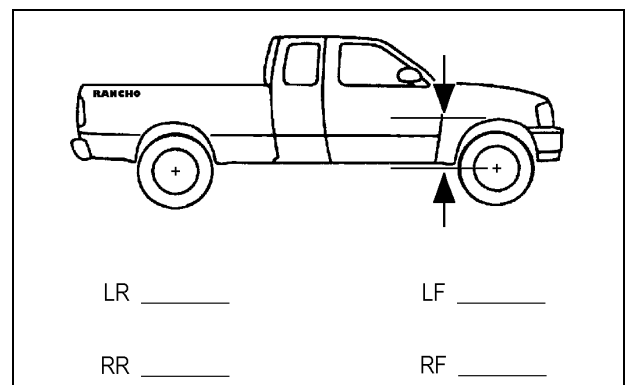

## Torque Specs

### Front Components

Transmission Cross Member	90 lb-ft
Transmission Mount to Cross Member	30 lb-ft
Lower Control Arm	125 lb-ft
Caster Link to Lower Control Arm	125 lb-ft
Caster Link to Front Axle	75 lb-ft
Lower Control Arm Adjuster Jam Nut	200 lb-ft
Caster Link Jam Nut	150 lb-ft
Front Bump Stop Spacer RS176443	20 lb-ft
Shock Absorber Upper Mount	17 lb-ft
Shock Absorber Lower Mount	56 lb-ft
Front Drive Shaft to Pinion Flange	81 lb-ft
Sway Bar end Link	75 lb-ft
Track Bar	125 lb-ft
Track Bar Jam Nut	150 lb-ft
Drag Link Adjustment Sleeve Clamp	26 lb-ft
Brake Hose to Caliper	23 lb-ft.
Brake Hose to Brake Tube	18 lb-ft.
Wheels (Lug Nuts)	110 lb-ft.

### Rear Components

Lower Control Arm Bracket 10mm Hardware	45 lb-ft
Lower Control Arm Bracket 12mm Hardware	75 lb-ft
Lower Control Arm Bracket 1/2" Hardware	65 lb-ft
Control Arm (upper and lower)	125 lb-ft
Control Arm Adjuster Jam Nut	200 lb-ft
Fuel Tank Skid Plate OE Bolts	73 lb-ft
Fuel Tank Skid Plate 10mm Bolts	45 lb-ft
Transfer Case Skid Plate Bolts	73 lb-ft
Body Mount Bolt	80 lb-ft
Track Bar	125 lb-ft
Track Bar Bracket RS176655 14mm Hardware	125 lb-ft
Track Bar Bracket RS176655 10mm Hardware	40 lb-ft
Track Bar Bracket RS176655 U-Bolt	30 lb-ft
Shock Absorber Upper Mount	23 lb-ft
Shock Absorber Lower Mount	56 lb-ft
Rear Bump Stop Spacer RS176444	20 lb-ft
Brake Line Drop Bracket RS176442	12 lb-ft
Sway Bar End Link	75 lb-ft
Sway Bar End Link Jam Nut	75 lb-ft
Brake Hose to Caliper	23 lb-ft.
Brake Hose to Brake Tube	18 lb-ft.
Wheels (Lug Nuts)	110 lb-ft

### STANDARD BOLT TORQUE & IDENTIFICATION

INCH SYSTEM			METRIC SYSTEM			
Bolt Size	Grade 5	Grade 8	Bolt Size	Class 8.8	Class 10.9	Class 12.9
5/16	15 LB-FT	20 LB-FT	M6	5 LB-FT	9 LB-FT	12 LB-FT
3/8	30 LB-FT	35 LB-FT	M8	18 LB-FT	23 LB-FT	27 LB-FT
7/16	45 LB-FT	60 LB-FT	M10	32 LB-FT	45 LB-FT	50 LB-FT
1/2	65 LB-FT	90 LB-FT	M12	55 LB-FT	75 LB-FT	90 LB-FT
9/16	95 LB-FT	130 LB-FT	M14	85 LB-FT	120 LB-FT	145 LB-FT
5/8	135 LB-FT	175 LB-FT	M16	130 LB-FT	165 LB-FT	210 LB-FT
3/4	185 LB-FT	280 LB-FT	M18	170 LB-FT	240 LB-FT	290 LB-FT

<p><b>1/2-13x1.75 HHCS</b></p> <div style="display: flex; justify-content: space-around; align-items: center;"> <div style="text-align: center;"> <p>D T L X</p> </div> <div style="text-align: center;"> <p>Grade 5    Grade 8</p> </div> <div style="text-align: center;"> <p>L</p> </div> </div> <p>G = Grade Marking (bolt strength)    L = Length (inches)  D = Nominal Diameter (inches)        X = Description (hex head cap screw)  T = Thread Pitch (threads per inch)</p>	<p><b>M12-1.25x50 HHCS</b></p> <div style="display: flex; justify-content: space-around; align-items: center;"> <div style="text-align: center;"> <p>D T L X</p> </div> <div style="text-align: center;"> <p>P</p> </div> <div style="text-align: center;"> <p>L</p> </div> </div> <p>P = Property Class (bolt strength)    L = Length (millimeters)  D = Nominal Diameter (millimeters)    X = Description (hex head cap screw)  T = Thread Pitch (thread width, mm)</p>
---	---



[www.goranchocom](http://www.goranchocom)

Rancho Technical Department 1-734-384-7804.