

JL Spartacus Rear Bumper

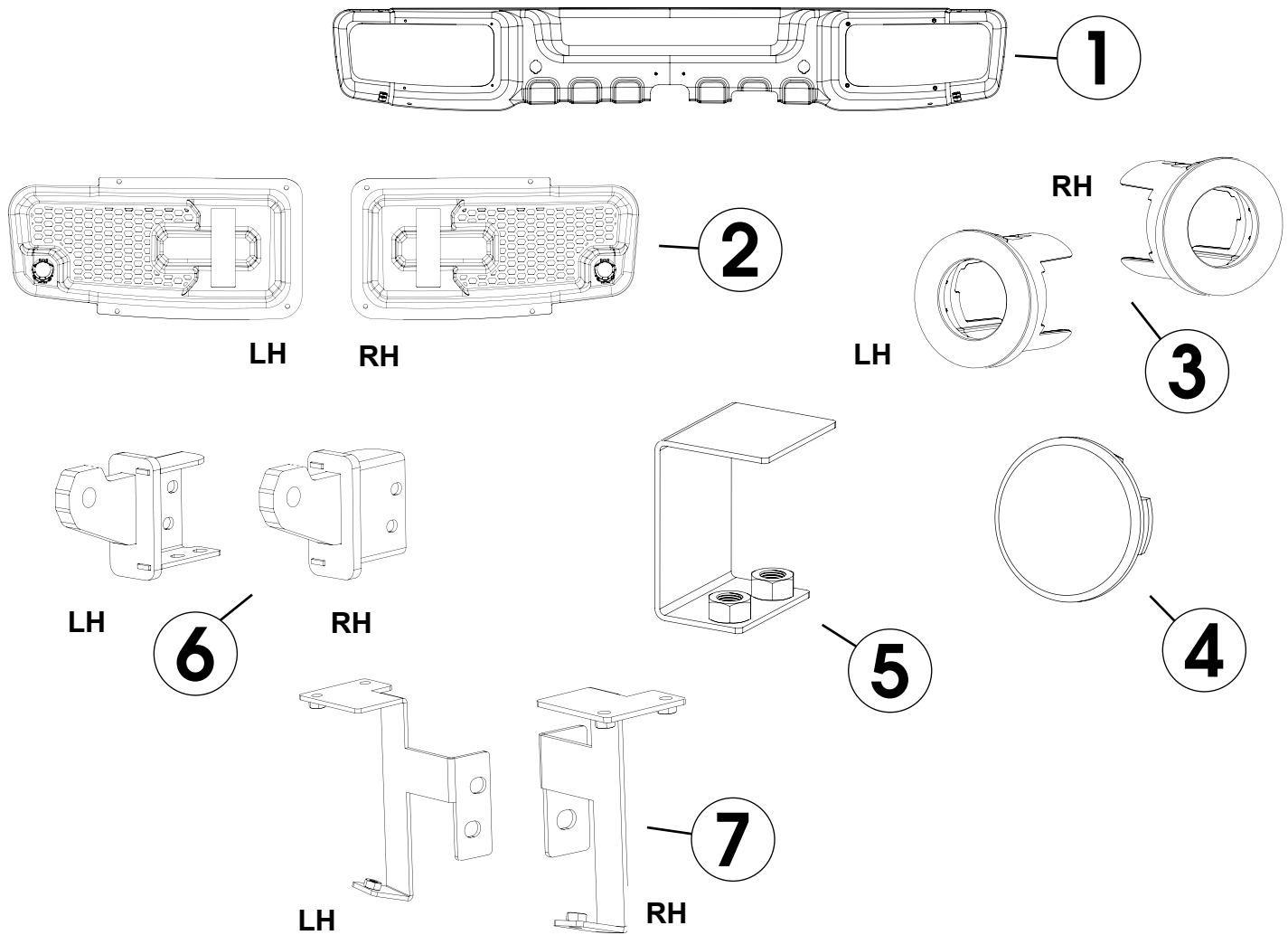

Components

1. Bumper Shell (1)
2. Plastic Inserts - LH / RH (2)
3. Sensor Holder - LH / RH (2)
4. Sensor Plug (4)
5. M14 Nut Plate (1)
6. D-Ring Bracket - LH / RH (2)
7. Mounting Bracket - LH / RH (2)

OMIX-ADA® TECHNICAL SUPPORT

PHONE: M-F 8am - 5pm EST 1-800-449-6649

 FOR WARRANTY OR TECH CONCERNS, EMAIL: webmaster@omixsupport.com
ATTN: STATE OF CALIFORNIA CONSUMERS
 **WARNING: Cancer and Reproductive Harm - www.P65Warnings.ca.gov.**

JL Spartacus Rear Bumper

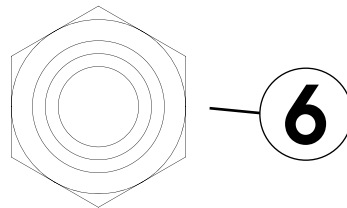
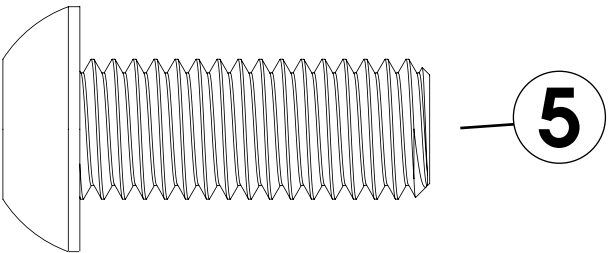
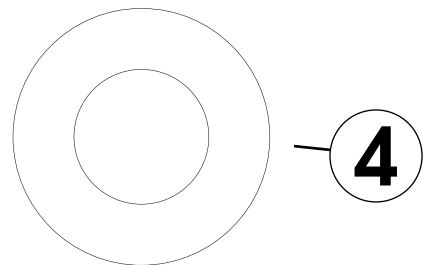
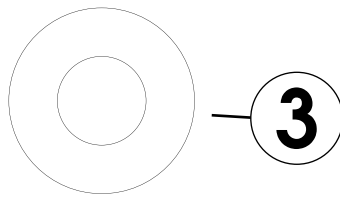
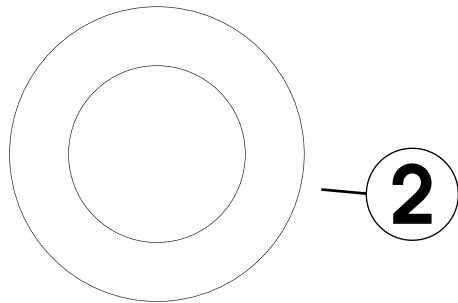
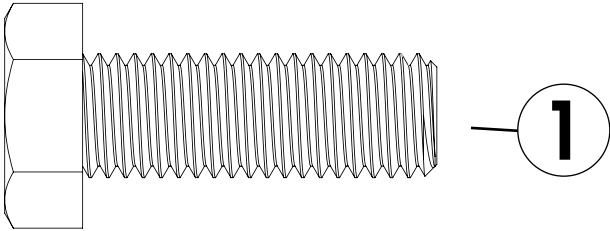

Hardware

- 1. M14 Hex Bolt (8)
 - 2. M14 Flat Washer (8)
 - 3. M4 Flat Washer (8)
 - 4. M10 Plastic Flat Washer (10)
 - 5. M10 Button Head Bolt (10)
 - 6. M4 Lock Nut (8)
-

JL Spartacus Rear Bumper

INSTALLATION INSTRUCTIONS

1. Remove factory rear bumper and tow hook. If vehicle is equipped with backup sensors, remove from bumper.

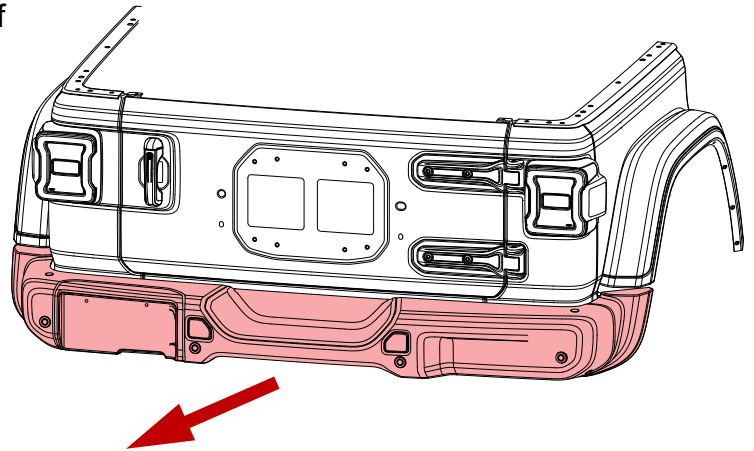

2. Attach plastic insert to bumper and secure with M4 locknuts and washers. Repeat for both sides.

x4

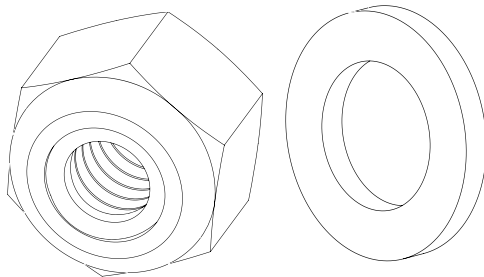

M4 LOCKNUT AND
WASHER

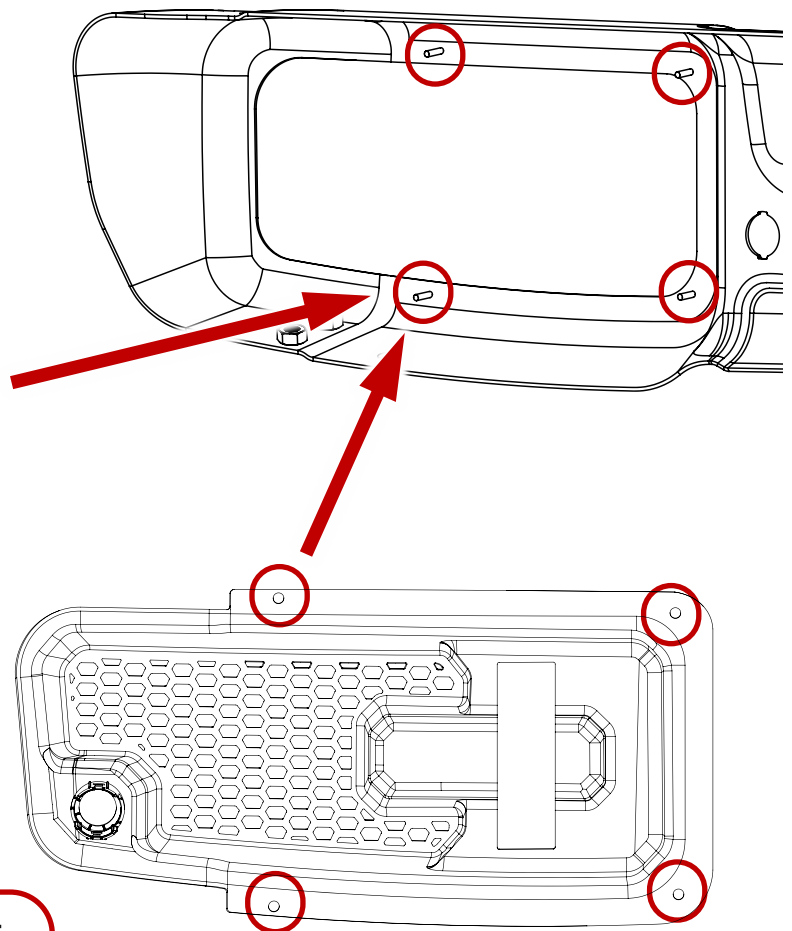

PLASTIC INSERT

JL Spartacus Rear Bumper

3. Install sensor holders to bumper.

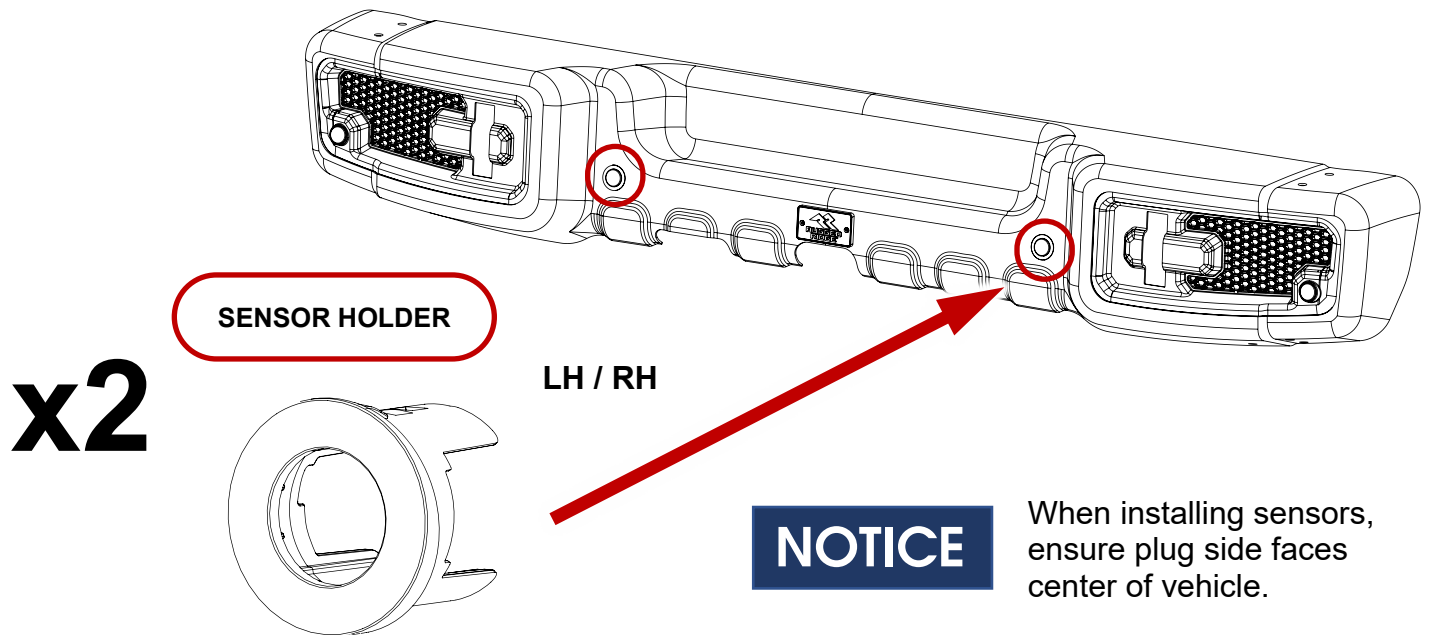

4. Insert sensors or plugs into sensor holders.
Repeat for both sides of bumper.

- a. If equipped, insert sensor into sensor holders.
- b. If not equipped, insert sensor plug.

x4

SENSOR PLUG

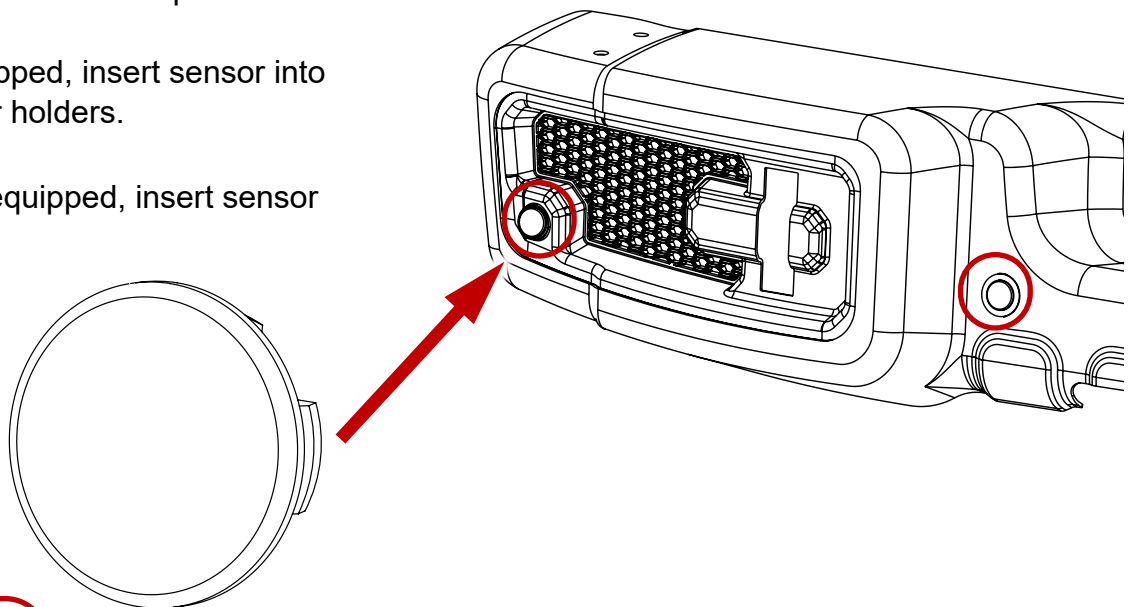

JL Spartacus Rear Bumper

5. Install M14 nut plate into passenger side frame rail.

x1

M14 NUT PLATE

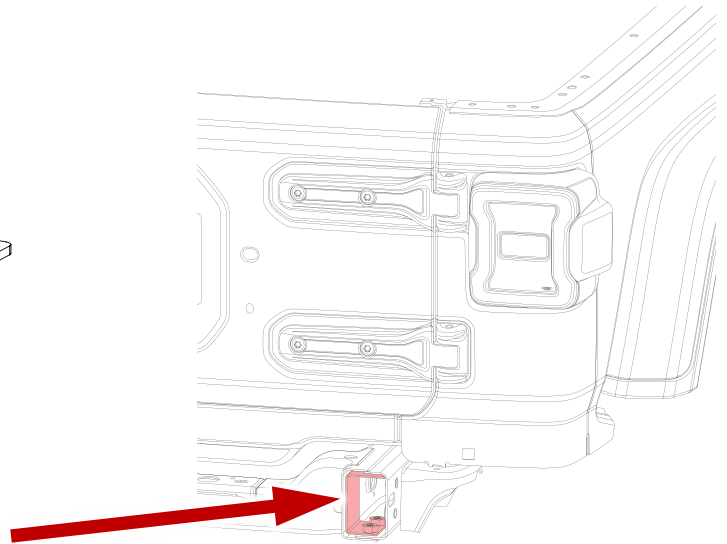
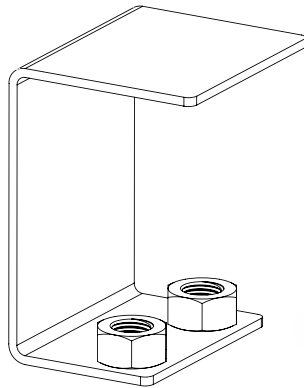

6. Install D-ring Bracket over the frame rails on both sides. Install M14 screws and washers underneath.

D-RING BRACKET

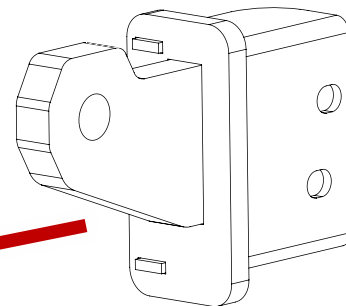
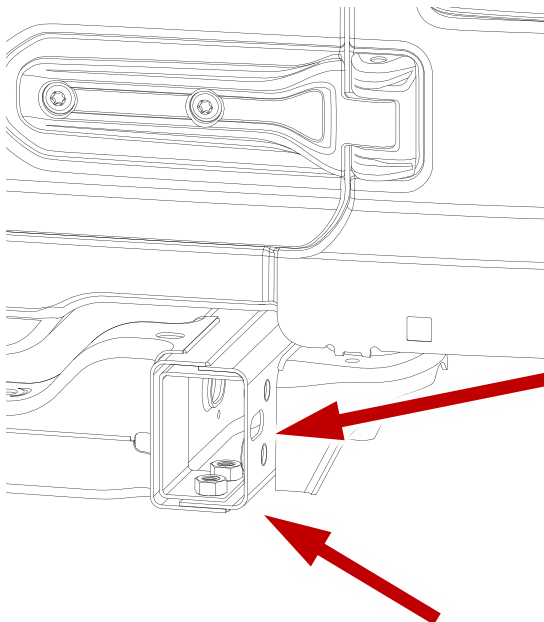

x2

M14 SCREWS AND WASHERS

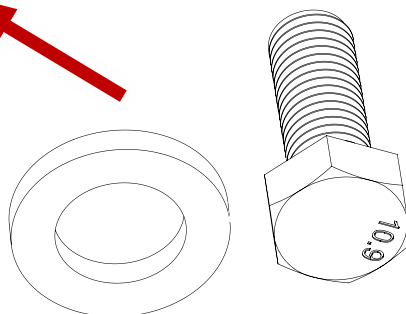

JL Spartacus Rear Bumper

7. Install mounting brackets to D-ring brackets on both sides using M14 hardware.

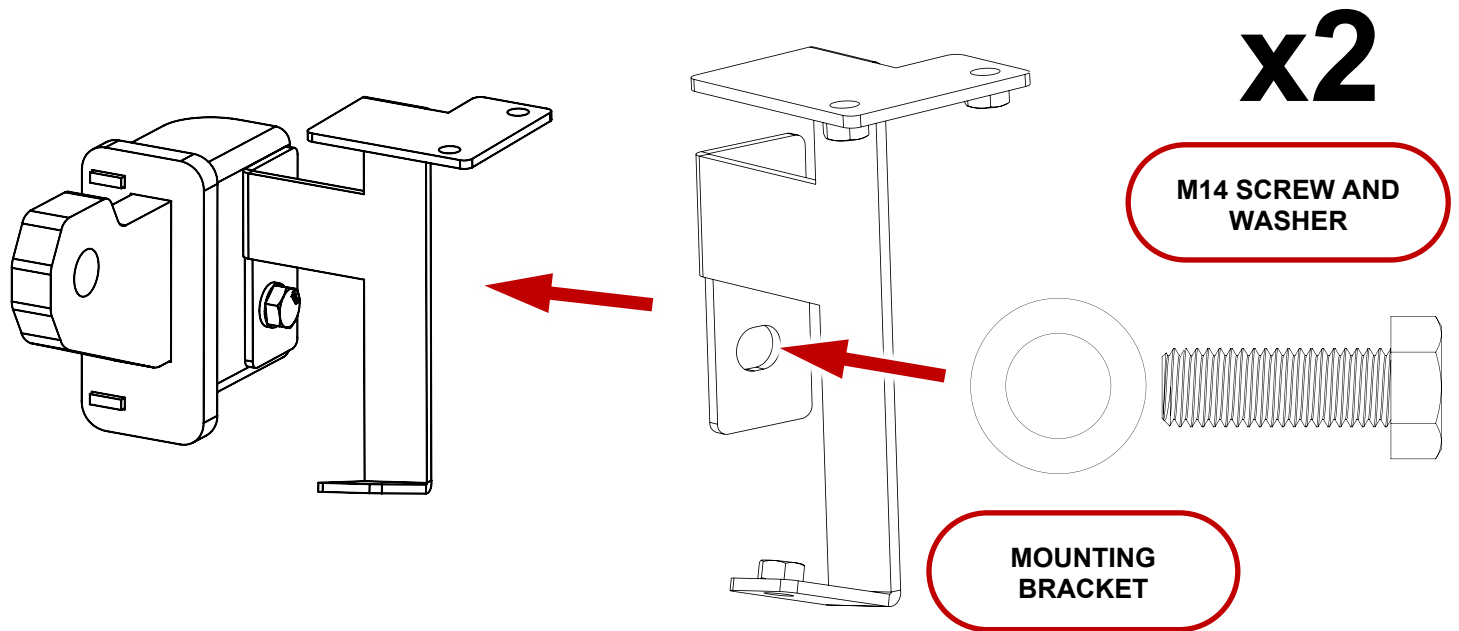

8. Position bumper shell on vehicle at D-ring mounting points.

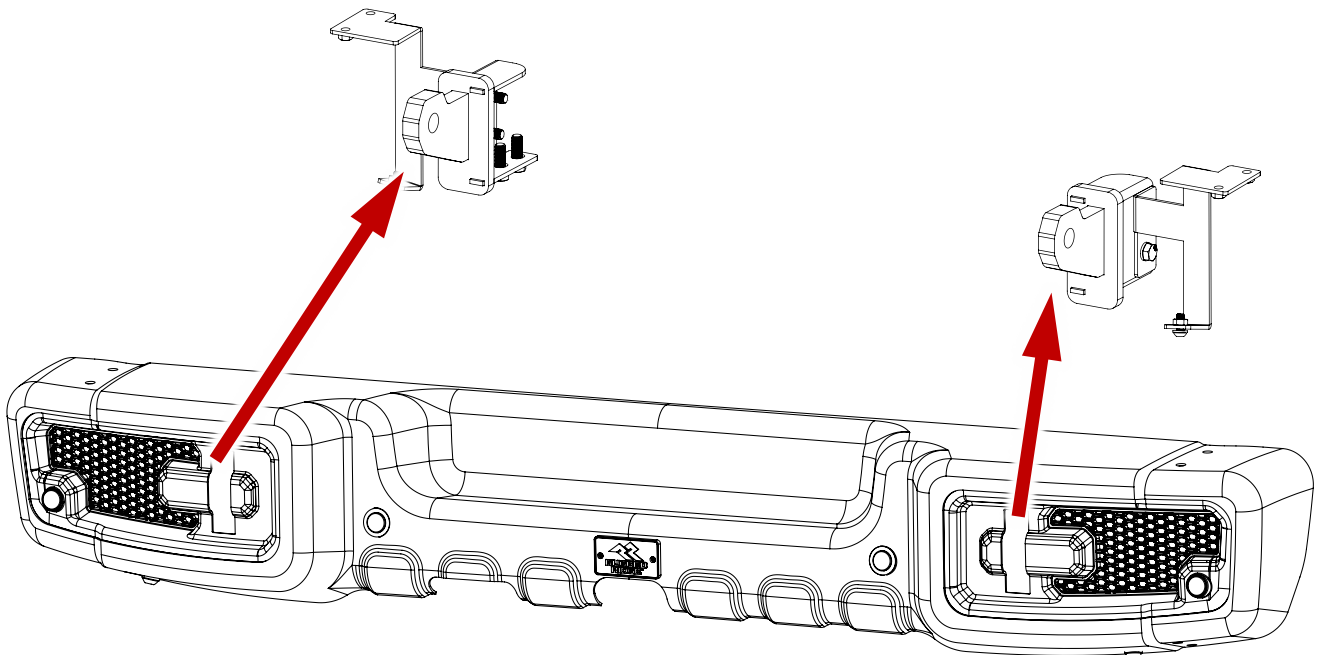

JL Spartacus Rear Bumper

9. Insert button head bolts to ends of bumper.

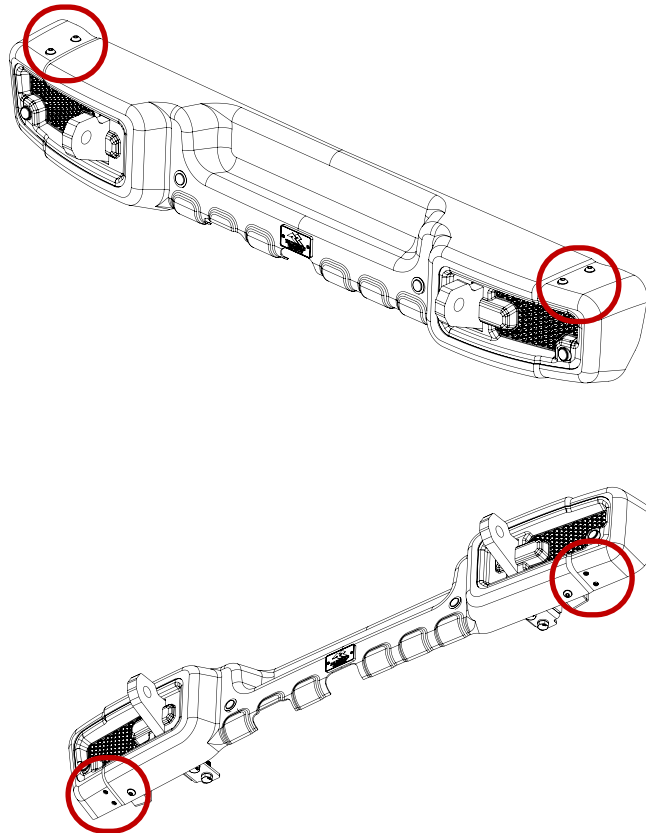

x10

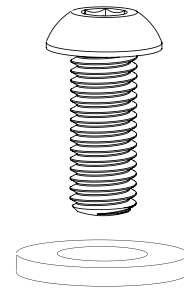

**BUTTON
HEAD BOLT
AND WASHER**

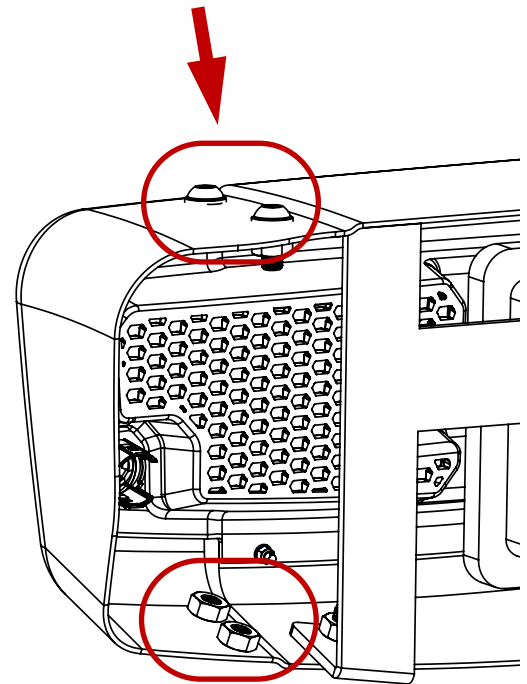

10. Adjust and tighten all bolts. Reconnect sensor electrical, if equipped.

