



Rusty's Off-Road Products  
7161 Steele Station Road  
Rainbow City, AL 35906  
1-256-442-0607  
[www.rustysoffroad.com](http://www.rustysoffroad.com)

## Rusty's JK Rear Cargo Rack Kit RA-CR699-JK INSTALLATION INSTRUCTIONS

Last Revised: 2/6/2018

### Introduction:

Rusty's recommends that this installation be performed by a certified automotive technician or a person with professional mechanical knowledge. Installing this kit without this expertise may jeopardize the handling and safety of the vehicle.

Read instructions several times before starting. Be sure you have all the needed parts and know where they install. Read each step completely as you go. Exhaust modifications may be necessary. Prior to drilling or cutting, check behind the surface being worked on for any wires, lines, or hoses that could be damaged. After any drilling or cutting, remove burrs and grind smooth any surfaces. An inclinometer or similar tool may be needed to measure driveshaft angles before and after the installation.

### Warning:

- It is the owners' responsibility to inspect all Rusty's products for proper torque specs to prevent loosening of components.
- Seat belts and shoulder harnesses should be worn at all times.
- Re-check all bolts and nuts after the first 100 miles and after any off-road usage during the first 300 miles.
- Although all of our products are made from the highest quality materials possible, they are not a substitute for Safe and Careful driving. In other words, have good safe on-road / off-road sense. Know the terrain, the speed limitations, and any obstacles that may lie ahead. Please remember to preserve our right to enjoy public land through the proper use of off-road vehicles.

### Before Starting Installation:

1. Carefully Read all warnings and instructions completely before beginning.
2. Verify all parts have been received in this kit by checking the parts list on page#2 of this document.
3. Only install this kit on the vehicle for which it is specified.
4. Park the vehicle on a clean, dry, flat, level surface and block the tires so the vehicle cannot roll in either direction.
5. Be certain the vehicle is safely secured on jack stands or a vehicle lift prior to working around or under a vehicle. Never rely on a jack alone to support a vehicle's weight; use appropriately rated stands to support the vehicle's frame and any other heavy components.



For Questions or Suggestions, contact our Tech Department (256-442-0607)



Rusty's Off-Road Products  
 7161 Steele Station Road  
 Rainbow City, AL 35906  
 1-256-442-0607  
[www.rustysoffroad.com](http://www.rustysoffroad.com)

**Parts List:**

**Note:** Please be sure that you have all the provided parts listed below before continuing with the installation.

<b>Part #</b>	<b>DESCRIPTION:</b>	<b>Quantity</b>
RA-CR699-JK-DSP	Rusty's Cargo Rack Driver Side Panel	1
RA-CR699-JK-PSP	Rusty's Cargo Rack Passenger Side Panel	1
RA-CR699-JK-LFP	Rusty's Cargo Rack Long Face Panel	2
RA-CR699-JK-DSMB	Rusty's Cargo Rack Driver Side Mounting Bracket	1
RA-CR699-JK-PSMB	Rusty's Cargo Rack Passenger Side Mounting Bracket	1
RA-CR699-JK-SR	Rusty's Cargo Rack Support Rails	6
67563080	1/4"-20 x 3/4" Length Button Head Cap Screw	24
67563163	1/4"-20 x 1-1/4" Length Button Head Cap Screw	12
67483768	1/4"-20 Serrated Flange Nut	36
67443564	M6 x 1.00 x 25mm Length Hex Drive Flange Bolt	4
67492967	M6 x 12mm O.D. Flat Washer	4

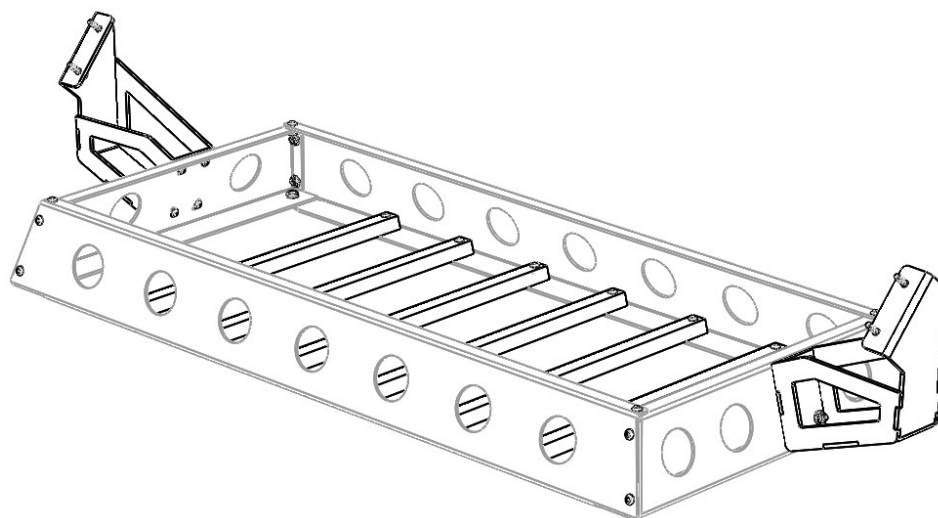

For Questions or Suggestions, contact our Tech Department (256-442-0607)

## Cargo Rack Assembly Instructions

1. To start the assembly process we suggest that you layout each of the cargo rack side panels and identify each panel.
2. Assemble one of the short side panels and one of the long face panels, by sliding the short side panel into the C shaped section of the long face panel as illustrated below.

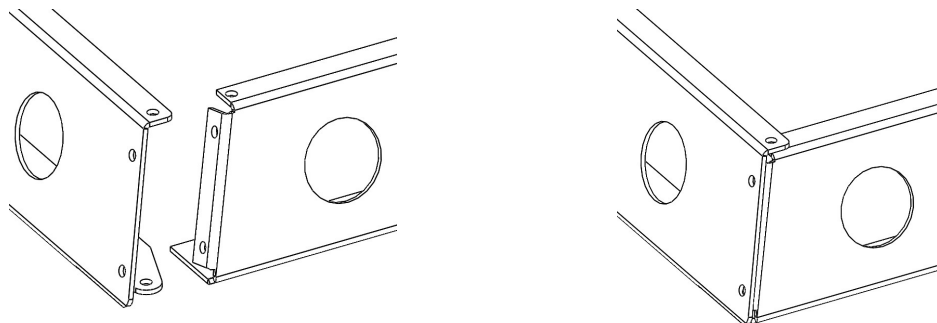

3. Start a 1/4"-20 x 3/4" Length BHCS and 1/4"-20 Serrated Flange Nut through the top and bottom hole locations as illustrated below. (**Note:** Do not fully tighten hardware at this time.)

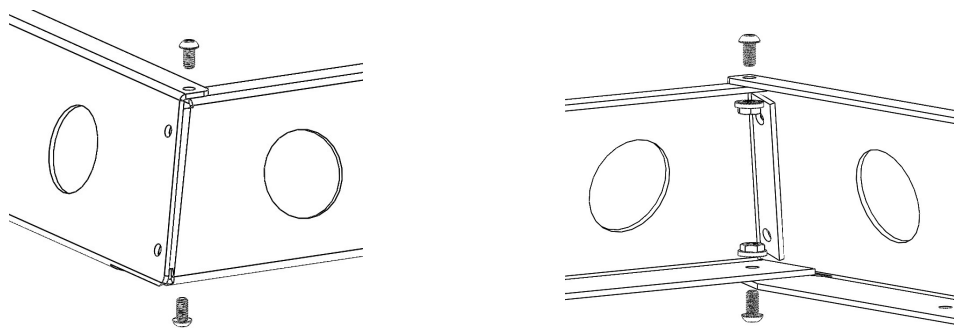

4. Repeat steps 2 & 3 to complete the installation of the remaining cargo rack panels. You should now have a box consisting of the cargo rack's outer shell.
5. Start the 1/4"-20 x 3/4" Length BHCS and 1/4"-20 Serrated Flange Nut through the hole locations illustrated below on all of the corners. (**Note:** Do not fully tighten hardware at this time.)

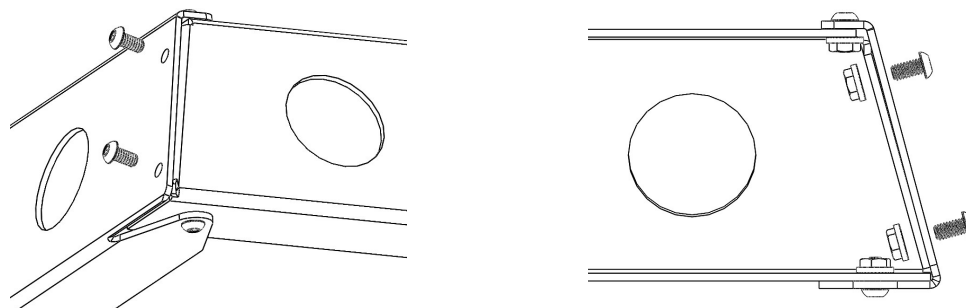



### Cargo Rack Assembly Instructions

- Once all the hardware is started, use a 5/32" Allen Wrench tighten all of the installed 1/4"-20 x 3/4" Length BHCS until snug. (**Note:** Do not overtighten!)
- Install and tighten the (Qty.6) Rusty's Cargo Rack Support Rails on the inside of the assembled cargo rack using the (Qty.2 Per Rail) 1/4"-20 x 1-1/4" Length BHCS and (Qty.2 Per Rail) 1/4"-20 Serrated Flange Nuts as illustrated below. (**Note:** The orientation of the hardware here is not critical to assembly.)

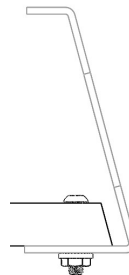
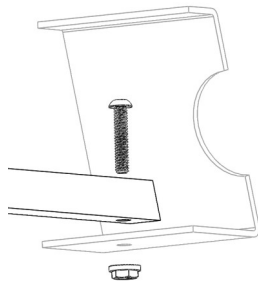

- Cargo Rack assembly is now complete.

### Cargo Rack Installation Instructions

- Remove soft top side windows from vehicle to assist with the installation. On hardtop vehicles, skip to step 6.
- Unzip the cover located on the top side of the rear downward roll bar tube to gain access to the mounting points for the cargo rack.
- If applicable, remove the (Qty: 2) T-30 Torx screws from the driver side soft top support bar only.
- Install the provided driver side mounting bracket using the supplied M6 x 1.00 x 25mm Length Hex Drive Flange Bolt. Do not fully tighten the hardware, as you want to leave it loose enough to allow the mounting bracket to have about 1" of inward movement. (**Note:** Make sure that the roll bar padding is on each side of the bracket. You will have to slightly stretch it in order to make it fit on the out side of the rack mounting brackets.)
- Repeat steps 3 & 4 on the passenger side now that the soft top is supported again by the driver side brackets.
- Vehicles equipped only with a hardtop: simply install the provided driver side mounting bracket & passenger side mounting brackets using the supplied (Qty:2 Per Side) M6 x 1.00 x 25mm Length Hex Drive Flange Bolts. Leave the brackets loose at this time.

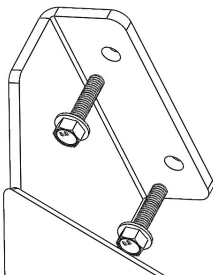

**Cargo Rack Installation Instructions (Continued)**

7. With the help of an assistant place the rack into position. The short sides of the rack will have the mounting points. Mount the rack so that the mounting points are closest to the front of the vehicle as illustrated below.

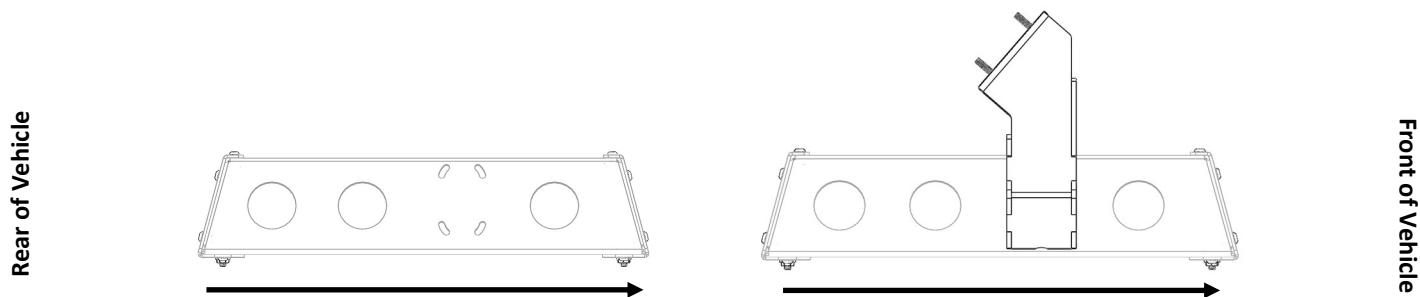

8. Fasten the cargo basket to the driver side mounting bracket using the supplied (Qty:4) 1/4"-20 x 3/4" Hex Bolts and 1/4"-20 Serrated Nuts as illustrated below.

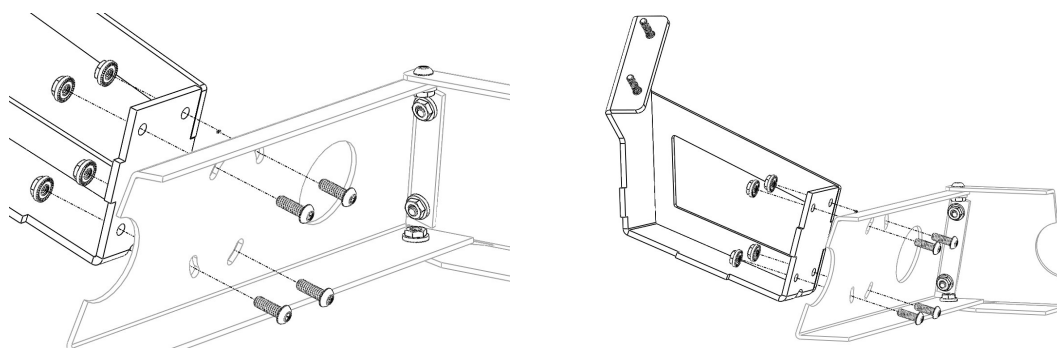

9. Repeat step 8 on the passenger side now.
10. Tighten the hardware used to hold the driver and passenger side mounting brackets to the roll bar.
11. Adjust the cargo basket to make sure that it sits level on the vehicle. (**Note:** We suggest using a digital level, angle finder, etc. in order ensure that the cargo rack is sitting level. Zero your digital level off of the flat portion on the sides of the jeep right above the soft top channel.)
12. Reinstall the roll bar padding onto the roll bar and use the pull tag of the zipper in order to close the zipper.
13. Installation is now complete.