

## Rusty's JL Wrangler Spare Tire Delete / License Plate Mount RC-TDM718-JL INSTALLATION INSTRUCTIONS

Last Revised: 3/11/2019

### Introduction:

Rusty's recommends that this installation be performed by a certified automotive technician or a person with professional mechanical knowledge. Installing this kit without this expertise may jeopardize the handling and safety of the vehicle.

Read instructions several times before starting. Be sure you have all the needed parts and know where they install. Read each step completely as you go. Exhaust modifications may be necessary. Prior to drilling or cutting, check behind the surface being worked on for any wires, lines, or hoses that could be damaged. After any drilling or cutting, remove burrs and grind smooth any surfaces. An inclinometer or similar tool may be needed to measure driveshaft angles before and after the installation.

### Warning:

- It is the owners' responsibility to inspect all Rusty's products for proper torque specs to prevent loosening of components.
- Seat belts and shoulder harnesses should be worn at all times.
- Re-check all bolts and nuts after the first 100 miles and after any off-road usage during the first 300 miles.
- Although all of our products are made from the highest quality materials possible, they are not a substitute for Safe and Careful driving. In other words, have good safe on-road / off-road sense. Know the terrain, the speed limitations, and any obstacles that may lie ahead. Please remember to preserve our right to enjoy public land through the proper use of off-road vehicles.

### Before Starting Installation:

1. Carefully Read all warnings and instructions completely before beginning.
2. Verify all parts have been received in this kit by checking the parts list on page#2 of this document.
3. Only install this kit on the vehicle for which it is specified.
4. Park the vehicle on a clean, dry, flat, level surface and block the tires so the vehicle cannot roll in either direction.
5. Be certain the vehicle is safely secured on jack stands or a vehicle lift prior to working around or under a vehicle. Never rely on a jack alone to support a vehicle's weight; use appropriately rated stands to support the vehicle's frame and any other heavy components.

**Parts List:**

**Note:** Please be sure that you have all the provided parts listed below before continuing with the installation.

<b>Part #</b>	<b>DESCRIPTION:</b>	<b>Quantity</b>
RC-TDM718-JL	Rusty's JL Wrangler Spare Tire Delete / License Plate Mount	1
RC-TDM718-JL-BCMB	Rusty's JL Wrangler Spare Tire Delete / License Plate Mount Backup Camera Mounting Bracket	1
LED-194-B	194 LED Bulb	1
LED-194-PC	194 LED Pigtail Connector	1
67563122	1/4"-20 x 1" Length Button Head Cap Screw	2
67563007	1/4"-20 x 1/2" Length Button Head Cap Screw	4
MC-9750K22	7/8" Head Diameter Plastic Round Plug (Fits 1/2" I.D.)	2

## Installation Instructions

Note: Save all factory components and hardware for reuse, unless noted.

1. Park the vehicle on a level surface before starting the installation process.
2. Remove the spare tire from the factory tire carrier mount. (Note: Have an assistant help you lift the tire off of the carrier.)
3. Loosen the (Qty:8) 13mm bolts marked in the image below. Do not fully remove hardware at this time to ensure that the factory tire carrier is still held into position.



4. Remove the rear spare tire mount 3rd brake light bracket cover by removing the (Qty:7) T25 Torx bolts marked in the image below. Then remove the (Qty:4) T25 Torx bolts that secure the 3rd brake light mounting bracket to the spare tire carrier mount.

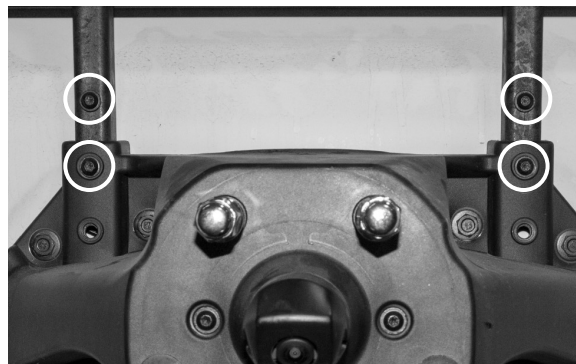

5. Carefully remove the 3rd brake light wiring harness from the inside of the 3rd brake light mounting bracket assembly. (**Note:** Be careful not to damage this wiring harness or connector so that it can be reused in the reassembly.)
6. Remove the 3rd brake light from the mount by removing the (Qty:2) T25 Torx bolts then disconnect the wiring harness from the 3rd bracket light connector. (**Note:** Retain hard ware to be reused.)

## Installation Instructions (Continued)

Note: Save all factory components and hardware for reuse, unless noted.

7. Remove the (Qty:8) 13mm bolts loosened in step#3 at this time to remove the entire factory spare tire carrier from the tailgate assembly. (**Note:** Retain hard ware to be reused.)
8. With the help from an assistant have them hold the factory spare tire mount and remove (Qty:2) T25 Torx bolts shown in the image below. Press against the lug nut studs to remove the lug nut plate/back up camera mount from the spare tire mount.



9. Remove the back up camera from the lug nut plate/back up camera mount by removing the (Qty:3) T8 Torx bolts as shown in the image below. Once the camera is unbolted disconnect wire by unplugging the connector on the back side of the camera. (**Note:** Retain hardware to be reused.)

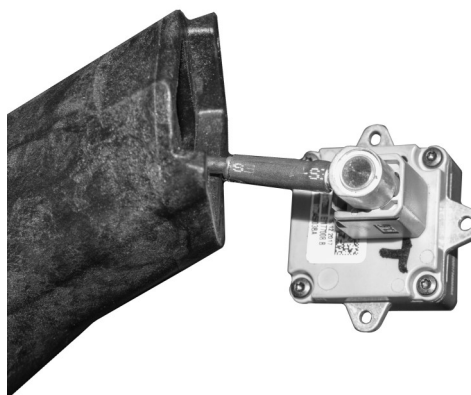
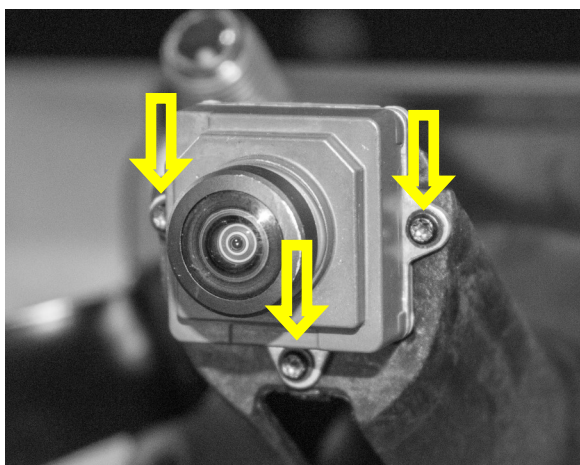

10. Pull the back up camera wire from the back side of the lug nut plate/back up camera mount and set aside the lug nut plate/back up camera mount for reuse. (**Note:** Be careful not to damage this wiring harness or connector so that it can be reused in the reassembly.)



## **Installation Instructions (Continued)**

Note: Save all factory components and hardware for reuse, unless noted.

11. Clean all of the exposed surfaces that will be covered by the new Rusty's JL Wrangler Spare Tire Delete / License Plate Mount.
12. Prepare the supplied Rusty's JL Wrangler Spare Tire Delete / License Plate Mount by attaching the factory 3rd brake light using the (Qty:2) T25 Torx bolts retained from step 6.



13. Install the supplied 194 LED Pigtail Connector and 194 LED White Bulb by routing the wiring through to the back side of the Rusty's JL Wrangler Spare Tire Delete / License Plate Mount. Once the wiring is routed secure the tag light connector to the Rusty's JL Wrangler Spare Tire Delete / License Plate Mount by



## **Installation Instructions (Continued)**

Note: Save all factory components and hardware for reuse, unless noted.

16. Remove the rear passenger side tail light assembly. (Refer to Owner's Manual Section 7– Page 383)

17. Remove the rear passenger side interior panel

- A. Remove the seat belt retainer trim from the rear passenger side interior panel.
- B. Carefully pry the trim panel out of place, by starting at the front of the vehicle. The position of the panel snaps may vary in some models.

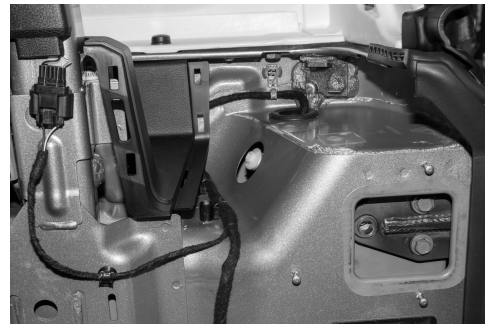

18. Remove the rear tailgate interior panel. Start with the lower left corner and pull outward carefully to remove the tailgate interior panel from the tailgate.



19. Before continuing you will need to source your own wiring and connectors in order to complete the following steps. It is recommended to use (Approximately 6ft.) 14-16 gauge wiring for this application.

## **Installation Instructions (Continued)**

Note: Save all factory components and hardware for reuse, unless noted.

20. Route the wiring for the supplied tag light by completing the following steps.

- A. Route the wiring through the factory vents in the tailgate, then follow along the factory wiring harness shown in the images below.

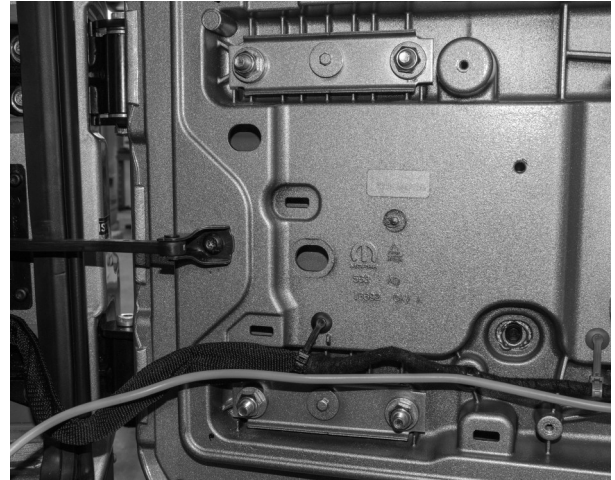
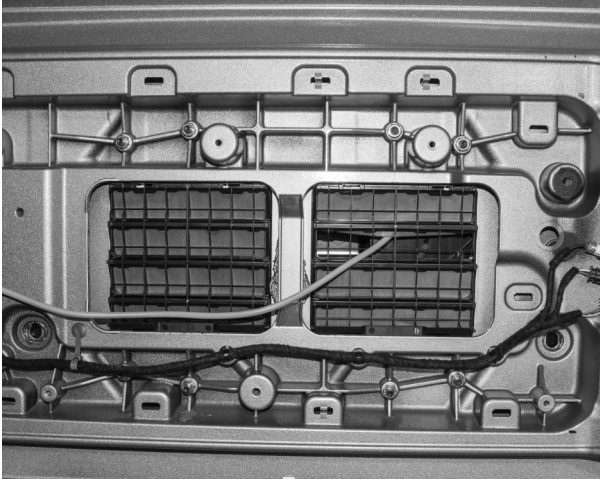

- B. Route the wiring through the factory grommet shown in the image below, then follow along the factory wiring to the passenger side tail light.





## Installation Instructions (Continued)

Note: Save all factory components and hardware for reuse, unless noted.

21. Prepare the passenger side tail light to access the wiring harness.

- A. Remove the (Qty:3) Phillips Head Screws that secure the plastic wiring cover to the back of the tail light shown in image 21-A.
- B. Squeeze the clip shown in image 21-B to remove the plastic wiring cover from the back of the tail light.

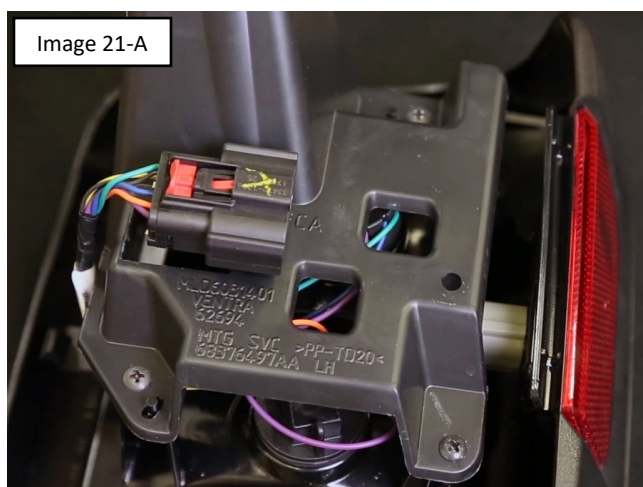

- C. The tail light wiring harness should now be easily accessible to wire in the supplied tag light.





## Installation Instructions (Continued)

Note: Save all factory components and hardware for reuse, unless noted.

22. Connect the wiring routed from the supplied tag 194 LED Pigtail Connector to the factory Blue and Purple Wires on the Passenger Side Tail Light. It is suggest to double check the polarity of each wire to ensure in the event that factory harness varies from the current color wiring harness at a later date. Test that the tag light comes on when the head lights are turned on.

## Factory Wiring Harness

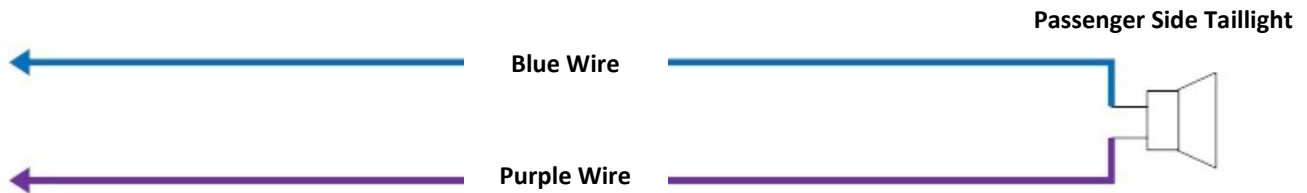

## Factory Wiring Harness With Tag Lamp Wires Connected

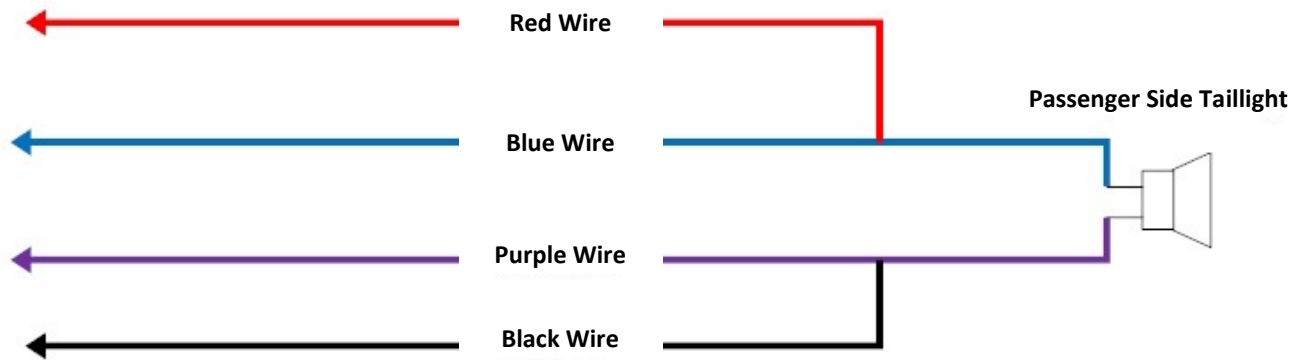

23. Ensure that all wiring connections are secure and reassemble the tail light by reversing the steps in completed in step 21.

## Installation Instructions (Continued)

Note: Save all factory components and hardware for reuse, unless noted.

24. Install the factory backup camera by completing the following steps.

- A. Position the factory backup camera in the Rusty's JL Wrangler Spare Tire Delete / License Plate Mount. (**Note:** The camera should be aligned as shown in the image below. Position so that that centered tab is facing the ground the outer two tabs face outward.

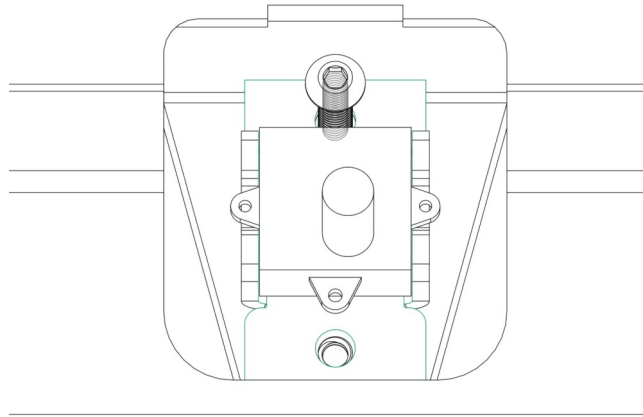

- B. Align and install the supplied Rusty's JL Wrangler Spare Tire Delete / License Plate Mount Backup Camera Mounting Bracket using the supplied (Qty:2) 1/4"-20 x 1" Length Button Head Cap Screws. Tighten the hardware just until the camera can not move or wiggle. You do not want to over tighten this hardware as this could cause damage to your camera.

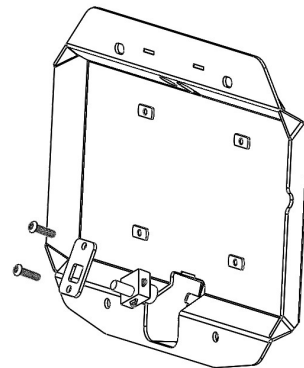
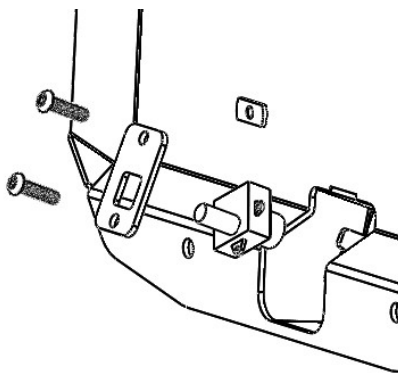

## **Installation Instructions (Continued)**

Note: Save all factory components and hardware for reuse, unless noted.

25. Install the Rusty's JL Wrangler Spare Tire Delete / License Plate Mount to the tailgate using the factory hardware.
26. Reinstall the passenger side tail light to the vehicle.
27. Reinstall interior panels that were removed for the installation process. Use caution not hit or damage any of the wiring ran during this process. It is suggest to route the wiring along the factory harness as much as possible to keep the wiring protected.
28. Install license plate using the supplied (Qty:4) 1/4"-20 x 1/2" Length Button Head Cap Screws.
29. The installation is now complete!

## **WARNING**

It is the owners' responsibility to inspect all Rusty's products for proper torque specs to prevent loosening of components. Seat belts and shoulder harnesses should be worn at all times. Re-check all bolts and nuts after the first 300 miles and after any off-road usage during the first 300 miles. Although all of our products are made from the highest quality materials possible, they are not a substitute for Safe and Careful driving. In other words, have good safe on-road / off-road sense. Know the terrain, the speed limitations, and any obstacles that may lie ahead. Please remember to preserve our right to enjoy public land through the proper use of off-road vehicles. Thank you for choosing Rusty's Off Road Products.