

Winch Ready JL Front Bumper

Installation Manual for 2018 - Current Wrangler (JL) #JLFBTB-001



⚠ WARNING ⚠ *To be safe while installing this product, read all messages and understand all instructions.*

⚠ WARNING ⚠ *Mount a winch per the winch maker instructions. Use safe winching practices.*

⚠ CAUTION ⚠ *Always wear safety glasses while installing or working on this product. Recheck nuts and bolts and re-torque after 250 miles. Periodically check the nuts and bolts during the life of the product. Do not use this product if it is damaged. Check state and local laws regarding permitted bumper sizes, types and heights.*

Winch Ready Front Bumper Parts & Tools

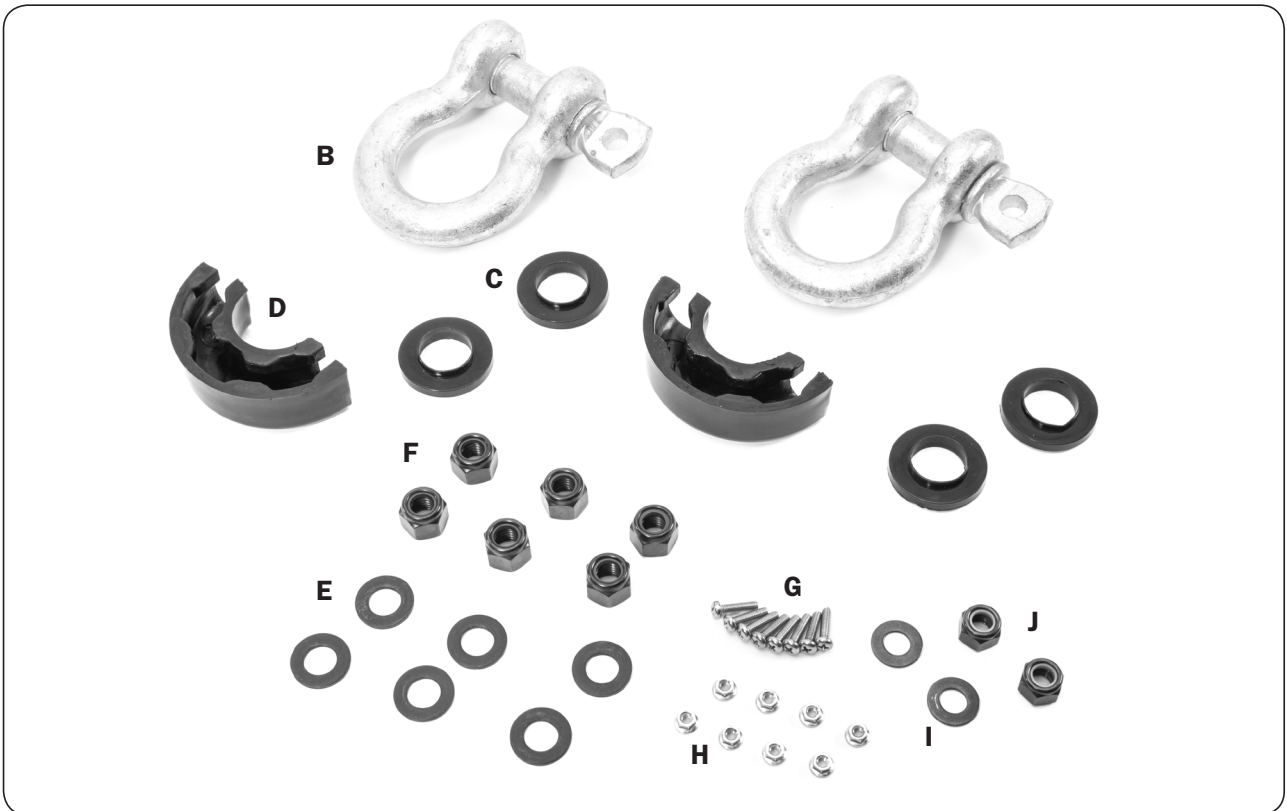

REQUIRED TOOLS:

- Safety Glasses
- 13, 16, & 18mm deep Sockets 19mm Socket
- Extension & Ratchet
- 7mm & 5/16" Sockets & Ratchet 7mm Box
- End Wrench
- T-20 Torx Driver
- Flat Blade Screwdriver
- Forked Clip/Trim Removal Tool

KIT CONTENTS LIST:

- A.) Winch Ready Front Bumper (1)
- B.) D-Rings (2)
- C.) D-Ring Washers (4)
- D.) D-Ring Isolators (2)
- E.) M12 Flat Washers (6)
- F.) M12 Stop Nuts (6)
- G.) M4 Phillips Screws (8)
- H.) M4 Flange Nuts (8)
- I.) M10 Flat Washers (2)
- J.) M10 Stop Nuts (2)

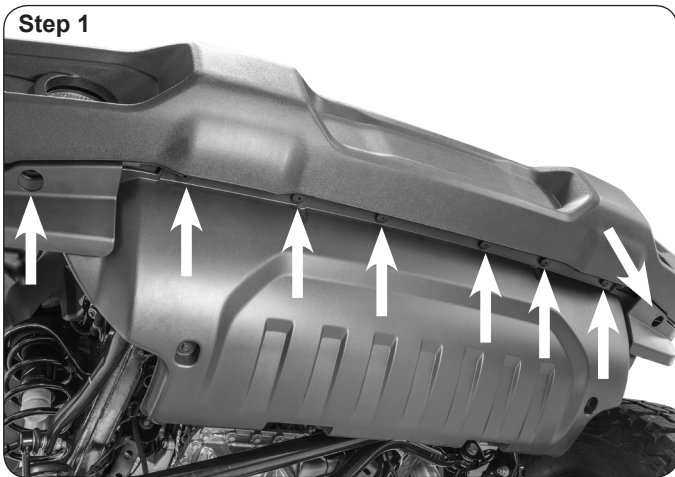

Put on safety glasses. Remove the 8 plastic push rivets on the underside of the bumper that are holding on the splash guard. (Step 1)

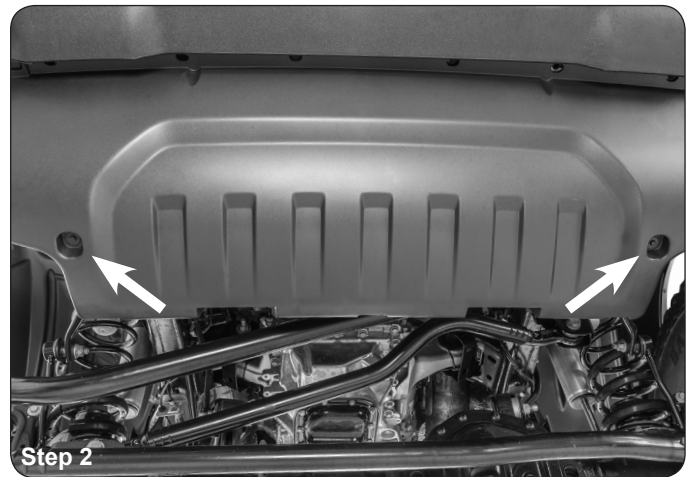

Remove the two screws on the under-side using a 5/16" socket. (Step 2) Re-move the splash guard. Note: This will not be reused.



Locate the frame guard plastic retainers on either side. (Step 3)



Remove the plastic retainers using a small flat blade screwdriver. (Step 4)

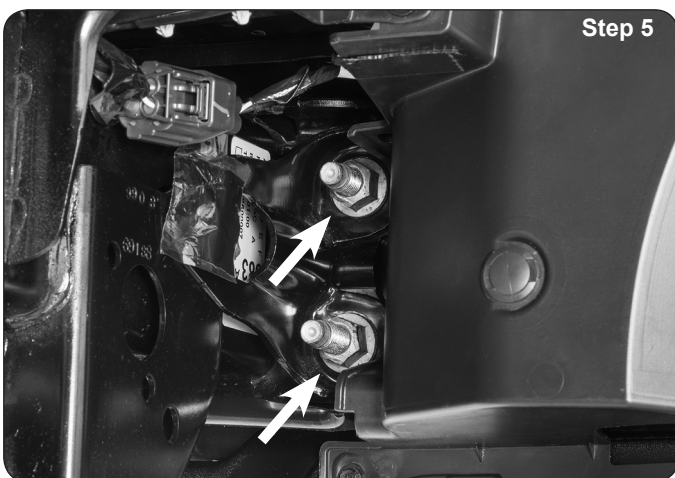

Using a 18mm deep socket remove the 8 bumper retaining nuts. There are 2 on the inside and outside of each frame rail. (Step 5)



Disconnect the fog light wiring harness plug and remove bumper. (Step 6)

Foglight Harness Removal from Original Bumper (Sahara & Rubicon Models Only)

JL Sport models will require 2010-18 Wrangler JK or 18-UP Wrangler JL Sahara/Rubicon with plastic bumper fog lamps.

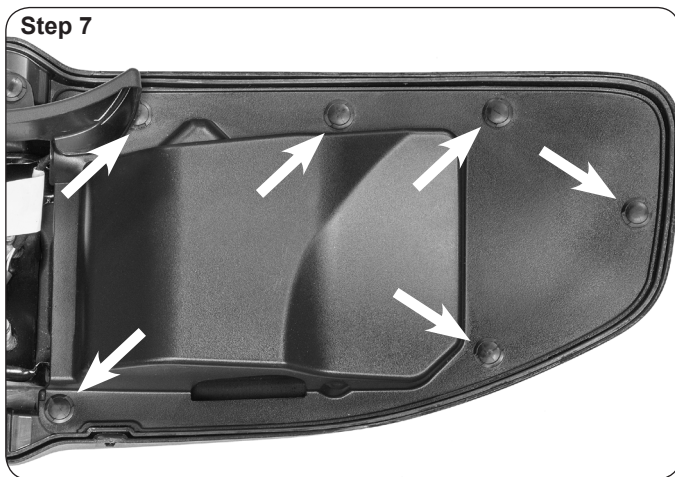

Remove the 6 plastic fasteners on either side holding the splash shields to bumper using a flat blade screwdriver. (Step 7)

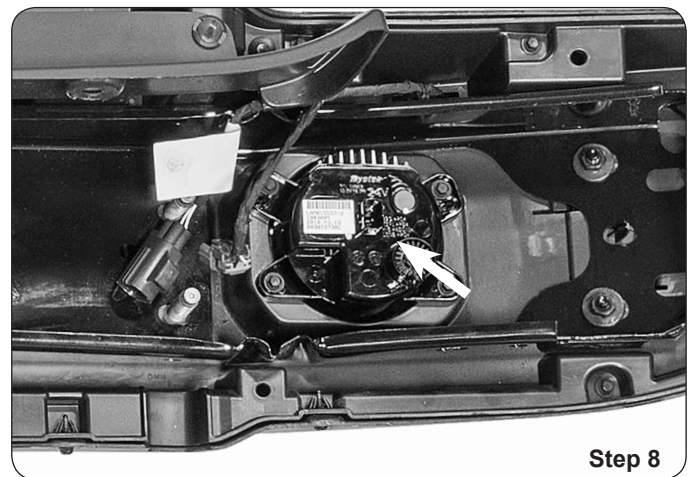

Unplug the factory wiring harness from the fog lights. (Step 8)



Remove the 8 nuts holding the metal sub structure to bumper fascia using a 13mm deep socket. (Step 9)

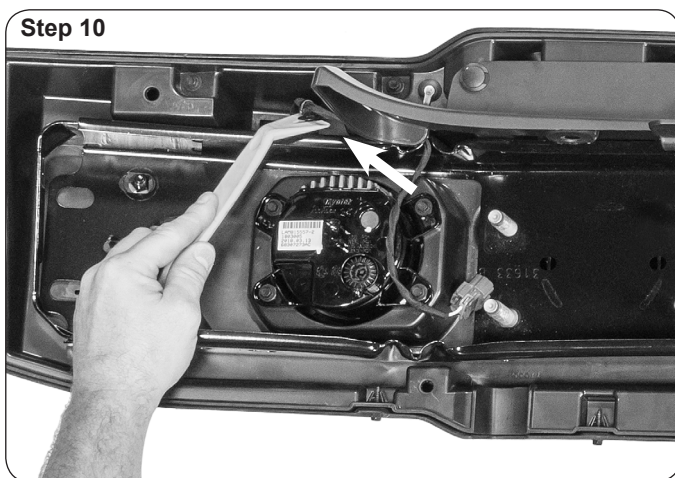

Remove the two fog light wiring harness retainers from metal sub structure using a trim removal tool. (Step 10) Now remove the metal sub structure.



Remove the 6 plastic fasteners holding the frame guard to bumper using a flat blade screwdriver. (Step 11)

Step 12

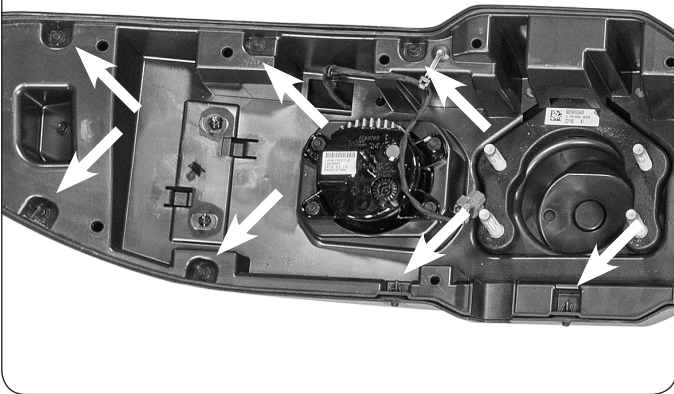

Remove the 24 screws holding bumper halves together using a 7mm socket. (Step 12)

Step 13

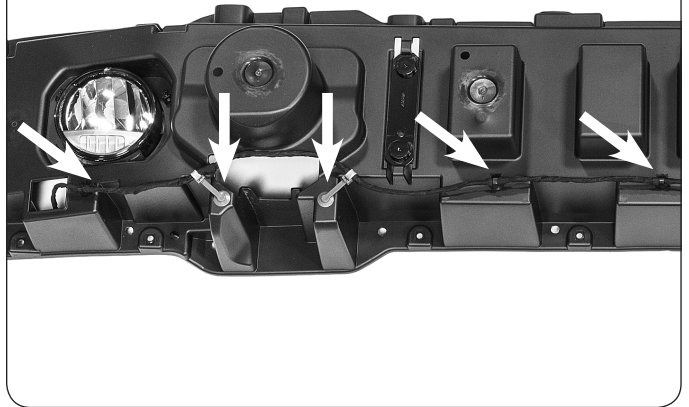

Separate bumper halves and turn over to access the fog light wiring harness. Remove harness using a trim removal tool and set aside for reuse later. (Step 13)

Step 14

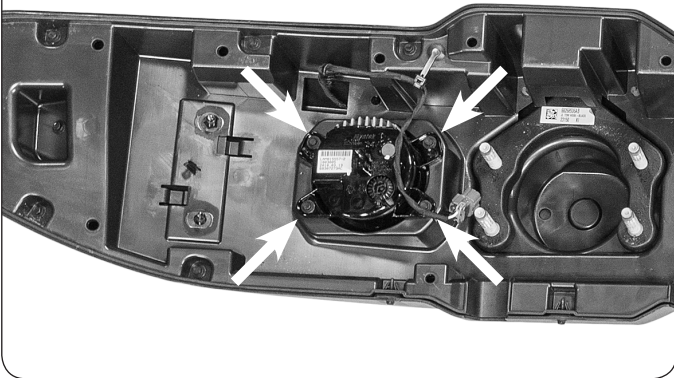

Remove the 8 screws holding the fog lamps to bumper using a 7mm socket and set aside for reuse. (Step 14)

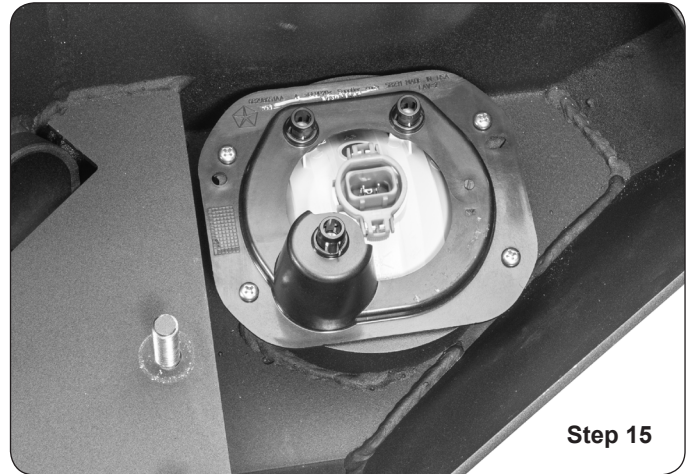

Install the fog lights with the 8 provided phillips head screws and flange nuts using a phillips screwdriver. (Step 15)

Step 16

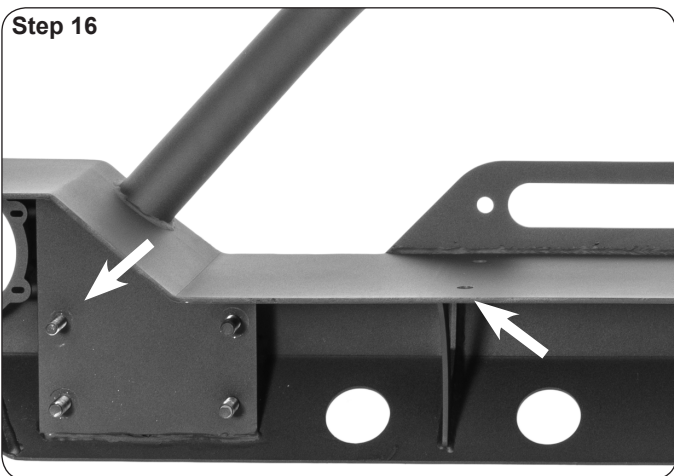

Before installing the bumper you must first install your winch and fairlead on to the bumper according to your winch's installation instructions.

Step 17

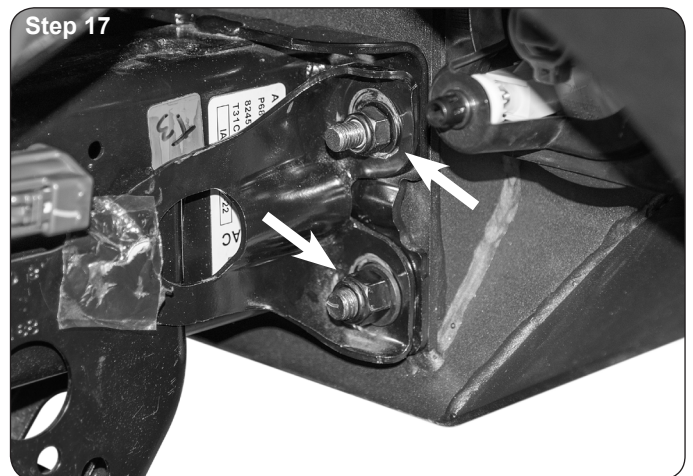

With the help of a friend lift the bumper into place on the frame of the Jeep. Secure the bumper to the Frame with the supplied M12 & M10 nuts and washers using 16mm & 18mm sockets and ratchet. (Step 17) Plug in your original fog light harness and secure where needed.