

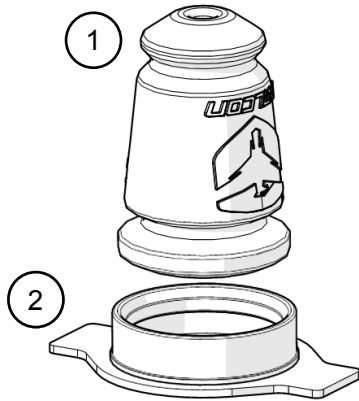

05-CURRENT TOYOTA TACOMA REAR BUMP STOPS AND 1.25" LEAF SPRING BLOCKS

#99-99-08-200-003 05-Current Toyota Tacoma, Rear, Bump Stops



#99-99-08-200-005 05-Current Toyota Tacoma, Rear, 1.25" Lift Blocks / Hardware

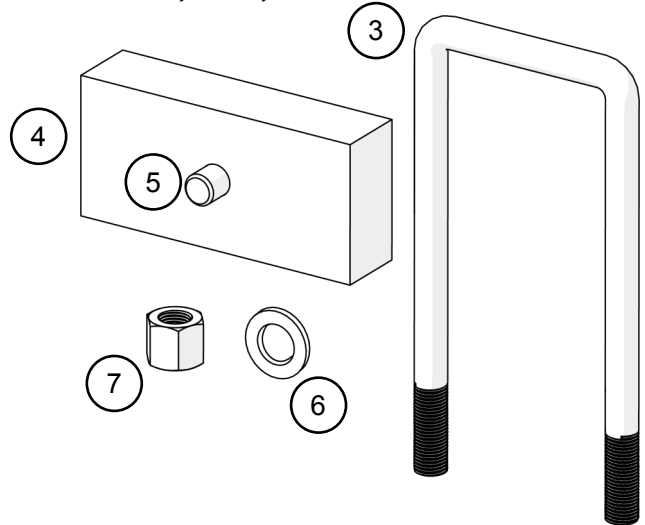

Item #	Part #	Description	Qty
	99-99-08-200-003	Bump Stops	
1	45-02-02-002	Foam, Snap-In, 3.90" Tall	2
2	45-03-01-005	Mount, Foam / Snap-In, Tacoma Leaf Spring Bumpstop Assembly	2
	99-99-08-200-006	Rear 1.25" Lift Blocks / Hardware	
3	22-02-25-080	Mounting Hardware, Square U-Bolt / 9/16 - 18 Threads, 2.50" Width, 8.00" Length	4
4	23-02-07-003	Mounting hardware, Bracket, Axle, Toyota Tacoma / 1.25" Lift Block	2
5	48-11-01-001	Misc. Hardware, Dowel Pin, .555" OD, 1.00" Length / Aluminum	2
6	52-04-02-004	Fastener, Washer, Alloy Steel, 9/16" x 1.469" OD / Yellow Zinc	8
7	52-06-02-003	Fastener, Nut, Steel, 9/16"-18 / Grade 8 / High Nut	8

Important Notes:

Prior to beginning this or any installation read these instructions to familiarize yourself with the required steps and evaluate if you are experienced and capable to personally perform these modifications. A factory service manual should be used in conjunction with these installation instructions.

Refer to the parts list to ensure that all necessary components and hardware has been included. If any parts are missing please contact your local TeraFlex dealer for assistance.

Tools needed:

- 19mm Deep Socket
- 1/2" Drive Ratchet

- General Mechanics Tool Set

REFER TO THE FACTORY SERVICE MANUAL FOR LIFT LOCATIONS.

1. Raise and support the rear of the truck at the frame.
2. Remove the rear tires and wheels.
3. Support the rear axle with a jack.
4. Remove the shocks from the rear axle.
5. Remove the leaf spring U-bolts and factory bump stops.
6. Lower axle to separate it from the leaf springs.

7. Insert Lift Block between spring perch and leaf springs. Raise the axle while aligning the leaf spring dowel pins to Lift Blocks and Lift Block dowel pins to the spring perch.
8. Install the Falcon bump stops in place of the factory bump stops.
9. Install replacement U-bolts onto leaf springs reusing the factory U-bolt plates.
10. Tighten the U-bolts evenly and torque to factory recommended specifications.
11. Reinstall shocks to the axle and torque to factory recommended specifications.

Recheck torque after the first
400-500 miles

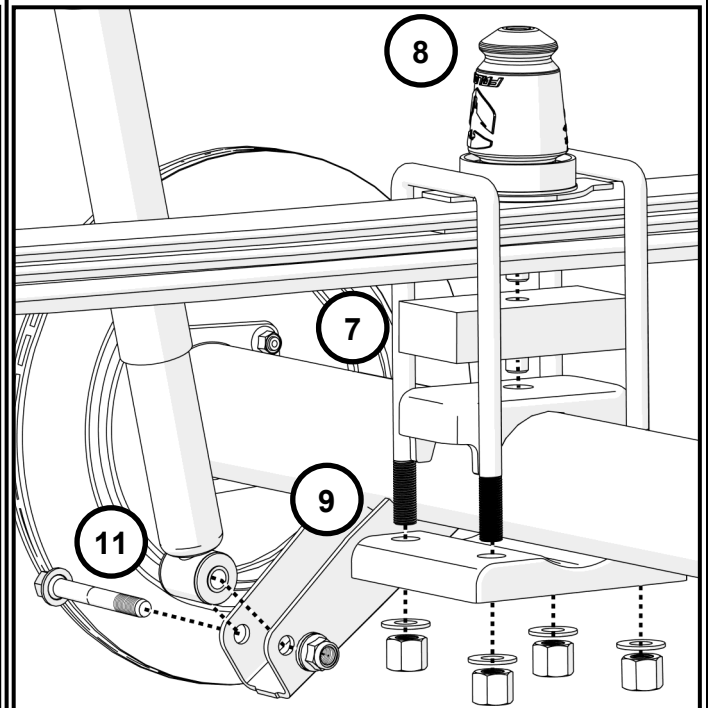
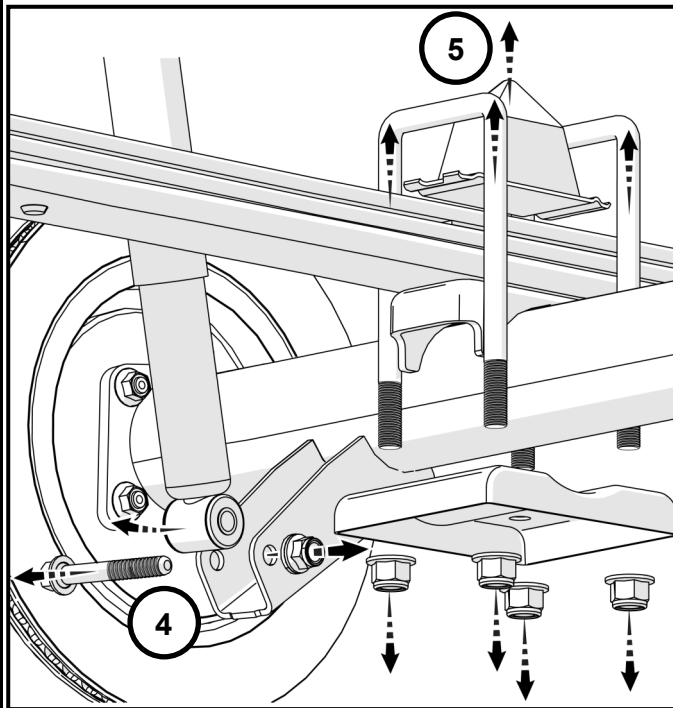

PRODUCT INFORMATION

MAINTENANCE INFORMATION:

It is the buyer's responsibility to have all suspension, drivetrain, steering, and other components checked for proper tightness and torque after the first 100 miles and every 3000 miles after that.

NOTICE TO INSTALLER:

The enclosed "Warning to Driver" sticker must be installed in the vehicle in driver's view. This sticker is to act as a constant safety reminder when operating the vehicle. It is your responsibility as the equipment installer to install the provided sticker and to forward the product instructions to the vehicle's owner for review. If a "Warning to Driver" sticker or product installation guide were not included in the kit, FREE replacement stickers and instructions are available by request. It is the installer's duty to ensure a safe and controllable vehicle after the modifications have been performed.

WARNING:

Neither the seller nor the manufacturer will be liable for any loss, damage, or injury directly or indirectly arising from the use of or inability to determine the use of these products. Before using, the user shall determine the suitability of the products for its intended use, and the user shall assume all responsibility and risk in connection therewith.

WARNING TO DRIVER:

This vehicle has been modified to enhance off road performance and has unique handling characteristics. Use in harsh environments can cause extreme stress on the components. Vehicle should be inspected after being off road to make sure that all the components are in working order and safe to travel on the highway. All fasteners should be checked so that they are at the correct torque specifications as the vibration and stresses from off roading may cause critical fasteners to work loose. Extra care should be taken to inspect the critical components, steering, and brake systems. During each oil change components such as arms, tie rod ends, etc. should be greased and checked for excessive wear. Any worn components should be replaced. When returning to the pavement always set or restore tire air pressure to the factory recommendation and connect or engage any disabled sway bar mechanisms. Because of the higher center of gravity and larger tires, this vehicle handles and reacts differently than many passenger cars, both on and off road. You must drive it safely! Extreme care should be taken to prevent vehicle rollover or loss of control, which can result in serious injury or death. Avoid sudden sharp turns or abrupt maneuvers. Generally, braking performance and capabilities are decreased when significantly larger/heavier tires are used, especially when used in combination with transfer case low-range reduction kits. Take this into consideration while driving. Do not add, alter or fabricate any factory or aftermarket parts to increase vehicle height over the intended height of the TeraFlex product purchased. Mixing component brand is not recommended. TeraFlex Inc. will not be responsible for any altered product or any improper installation or use of our products. We will be happy to answer any questions concerning the design, function, and correct use of our products. It is ultimately the buyer's responsibility to have all bolts/nuts checked for tightness after the first 100 miles and then every 3000 miles. Wheel alignment, steering system, suspension and drive line systems must be inspected by a qualified professional mechanic at least every 3000 miles.

TERAFLEX PRODUCT WARRANTY:

TeraFlex Inc. warrants TeraFlex Suspension products to the original retail purchaser to be free of defects in material and workmanship for as long as the original purchaser owns the vehicle on which products were originally installed.

Failure to complete regular maintenance (grease every 3000 miles) on TeraFlex FlexArms will void this warranty. All other conditions of the standard TeraFlex product warranty apply.

All TeraLow products are covered by the TeraFlex two (2) year warranty to be free of defects in material and workmanship for two years from date purchased.

TeraFlex axles are covered by a 12-month warranty to be free of defects in materials and workmanship.

This warranty does not cover or include product finish, improperly installed or applied products, improperly maintained products, products or components used for racing or competition or damage due to abuse or neglect, products that fail due to the use of larger tire and wheel combinations.

All returns must be accompanied by an original invoice. It is the customer's responsibility to remove the product from the vehicle. Shipping charges are the responsibility of the customer. TeraFlex Inc. will pay the return freight if the product meets the terms of warranty.

This warranty is for the replacement or repair of defective TeraFlex products only and does not include freight charges, labor charges for removal of or installation of TeraFlex or related products or components, costs incurred due to down time of the vehicle, or lost profits due to vehicle down time.

A returned goods authorization number (RGA#) must accompany any returned products. For more information please contact a TeraFlex customer service representative.

COPYRIGHT

©Copyright 2014. All rights reserved, TeraFlex Inc. Reproduction of this catalog and/or any of its contents without written permission is strictly prohibited.

TeraFlex® is a registered trademark of TeraFlex Inc. All trade names and logos including but not limited to TeraFlex, FlexArms, RockGuard, Monster, and LCG are protected by law and duplication of trade names and/or logos are strictly prohibited.

TeraFlex Inc. reserves the right to update, discontinue, redesign, modify finish, part number or component build parts if deemed necessary without written notice.

TeraFlex Inc., and any associated dealers are not responsible for misprints or typographical errors that may have inadvertently been made within this instruction sheet.

Jeep® and the Jeep® grill are registered trademarks of Fiat Chrysler Automobiles N.V., and have no affiliation with TeraFlex Inc.

Falcon Shocks, Inc.

5680 West Dannon Way
West Jordan, Utah 84081
Phone/801.713.3314
Fax/801.713.2313
www.falconshocks.com

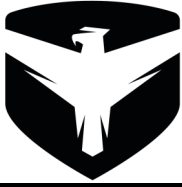

05-CURRENT TOYOTA TACOMA REAR BUMP STOPS

www.FALCONSHOCKS.com

#99-99-08-200-003 05-Current Toyota Tacoma, Rear, Bump Stops

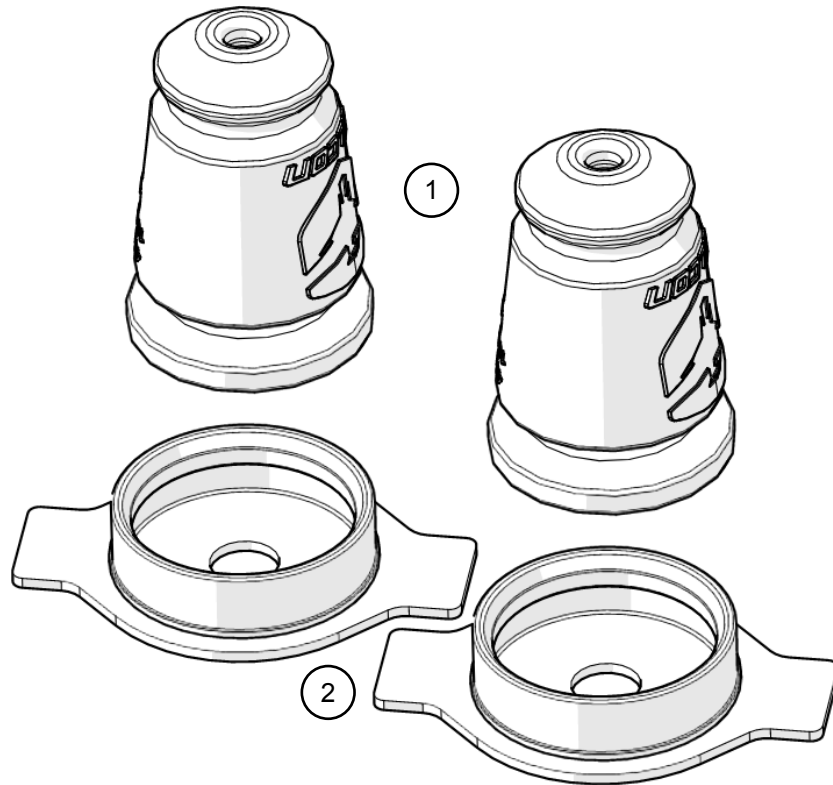

Item #	Part #	Description	Qty
1	45-02-02-002	Foam, Snap-In, 3.90" Tall	2
2	45-03-01-005	Mount, Foam / Snap-In, Tacoma Leaf Spring Bumpstop Assembly	2

Important Notes:

Prior to beginning this or any installation read these instructions to familiarize yourself with the required steps and evaluate if you are experienced and capable to personally perform these modifications. A factory service manual should be used in conjunction with these installation instructions.

Refer to the parts list to ensure that all necessary components and hardware has been included. If any parts are missing please contact your local TeraFlex dealer for assistance.

Tools needed:

- 19mm Deep Socket
- 1/2" Drive Ratchet
- General Mechanics Tool Set

This install must be done with the axle supported. If lifting the truck for easier access to the rear U-bolts then use jack stands to hold the rear axle in place.

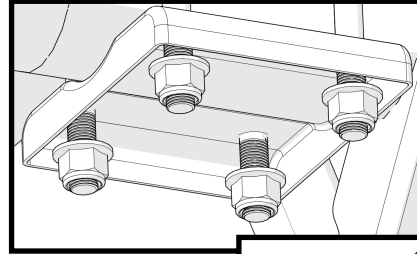

1. Loosen the rear axle leaf spring U-bolts and remove the factory bump stops.

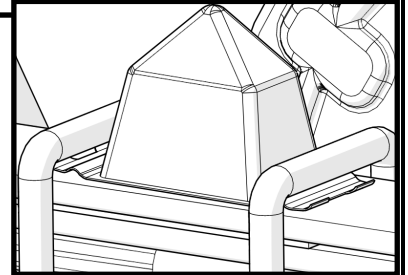

2. Press Falcon bump stops into each mount. **Note:** If a bump stop is difficult to install in mount, use a small amount silicone spray lube around the base of the bump stop.

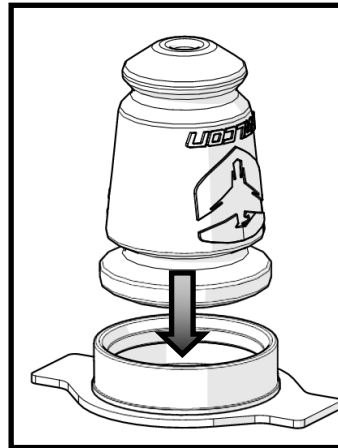

3. Install the Falcon bump stops in place of the factory bump stops.

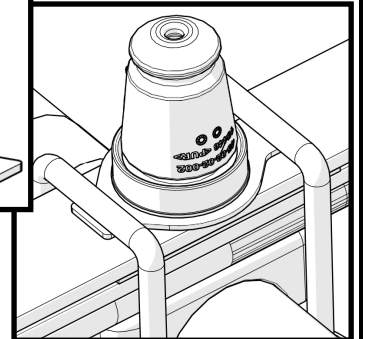

4. Tighten the U-bolts evenly and torque U-bolt nuts to factory recommended specifications.

Check torque after the first 400-500 miles

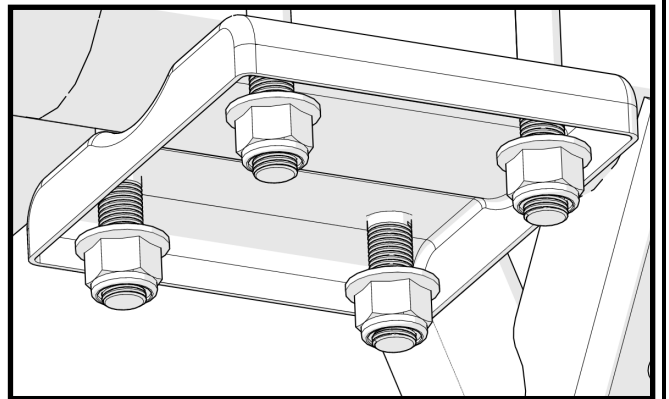

TERAFLEX

PRODUCT INFORMATION

MAINTENANCE INFORMATION:

It is the buyer's responsibility to have all suspension, drivetrain, steering, and other components checked for proper tightness and torque after the first 100 miles and every 3000 miles after that.

NOTICE TO INSTALLER:

The enclosed "Warning to Driver" sticker must be installed in the vehicle in driver's view. This sticker is to act as a constant safety reminder when operating the vehicle. It is your responsibility as the equipment installer to install the provided sticker and to forward the product instructions to the vehicle's owner for review. If a "Warning to Driver" sticker or product installation guide were not included in the kit, FREE replacement stickers and instructions are available by request. It is the installer's duty to ensure a safe and controllable vehicle after the modifications have been performed.

WARNING:

Neither the seller nor the manufacturer will be liable for any loss, damage, or injury directly or indirectly arising from the use of or inability to determine the use of these products. Before using, the user shall determine the suitability of the products for its intended use, and the user shall assume all responsibility and risk in connection therewith.

WARNING TO DRIVER:

This vehicle has been modified to enhance off road performance and has unique handling characteristics. Use in harsh environments can cause extreme stress on the components. Vehicle should be inspected after being off road to make sure that all the components are in working order and safe to travel on the highway. All fasteners should be checked so that they are at the correct torque specifications as the vibration and stresses from off roading may cause critical fasteners to work loose. Extra care should be taken to inspect the critical components, steering, and brake systems. During each oil change components such as arms, tie rod ends, etc. should be greased and checked for excessive wear. Any worn components should be replaced. When returning to the pavement always set or restore tire air pressure to the factory recommendation and connect or engage any disabled sway bar mechanisms. Because of the higher center of gravity and larger tires, this vehicle handles and reacts differently than many passenger cars, both on and off road. You must drive it safely! Extreme care should be taken to prevent vehicle rollover or loss of control, which can result in serious injury or death. Avoid sudden sharp turns or abrupt maneuvers. Generally, braking performance and capabilities are decreased when significantly larger/heavier tires are used, especially when used in combination with transfer case low-range reduction kits. Take this into consideration while driving. Do not add, alter or fabricate any factory or aftermarket parts to increase vehicle height over the intended height of the TeraFlex product purchased. Mixing component brand is not recommended. TeraFlex Inc. will not be responsible for any altered product or any improper installation or use of our products. We will be happy to answer any questions concerning the design, function, and correct use of our products. It is ultimately the buyer's responsibility to have all bolts/nuts checked for tightness after the first 100 miles and then every 3000 miles. Wheel alignment, steering system, suspension and drive line systems must be inspected by a qualified professional mechanic at least every 3000 miles.

TERAFLEX PRODUCT WARRANTY:

TeraFlex Inc. warrants TeraFlex Suspension products to the original retail purchaser to be free of defects in material and workmanship for as long as the original purchaser owns the vehicle on which products were originally installed.

Failure to complete regular maintenance (grease every 3000 miles) on TeraFlex FlexArms will void this warranty. All other conditions of the standard TeraFlex product warranty apply.

All TeraLow products are covered by the TeraFlex two (2) year warranty to be free of defects in material and workmanship for two years from date purchased.

TeraFlex axles are covered by a 12-month warranty to be free of defects in materials and workmanship.

This warranty does not cover or include product finish, improperly installed or applied products, improperly maintained products, products or components used for racing or competition or damage due to abuse or neglect, products that fail due to the use of larger tire and wheel combinations.

All returns must be accompanied by an original invoice. It is the customer's responsibility to remove the product from the vehicle. Shipping charges are the responsibility of the customer. TeraFlex Inc. will pay the return freight if the product meets the terms of warranty.

This warranty is for the replacement or repair of defective TeraFlex products only and does not include freight charges, labor charges for removal of or installation of TeraFlex or related products or components, costs incurred due to down time of the vehicle, or lost profits due to vehicle down time.

A returned goods authorization number (RGA#) must accompany any returned products. For more information please contact a TeraFlex customer service representative.

COPYRIGHT

©Copyright 2014. All rights reserved, TeraFlex Inc. Reproduction of this catalog and/or any of its contents without written permission is strictly prohibited.

TeraFlex® is a registered trademark of TeraFlex Inc. All trade names and logos including but not limited to TeraFlex, FlexArms, RockGuard, Monster, and LCG are protected by law and duplication of trade names and/or logos are strictly prohibited.

TeraFlex Inc. reserves the right to update, discontinue, redesign, modify finish, part number or component build parts if deemed necessary without written notice.

TeraFlex Inc., and any associated dealers are not responsible for misprints or typographical errors that may have inadvertently been made within this instruction sheet.

TERAFLEX, Inc.

5680 West Dannon Way
West Jordan, Utah 84081
Phone/801.713.3314
Fax/801.713.2313
www.teraflex.com

Jeep® and the Jeep® grill are registered trademarks of Fiat Chrysler Automobiles N.V., and have no affiliation with TeraFlex Inc.



Toyota Front Sway Bar Relocation Bracket Instructions

www.FALCONSHOCKS.com

Kit #23-02-05-999 Mounting Hardware (S), Bracket, Sway bar, Front / Relocation / Toyota / Kit

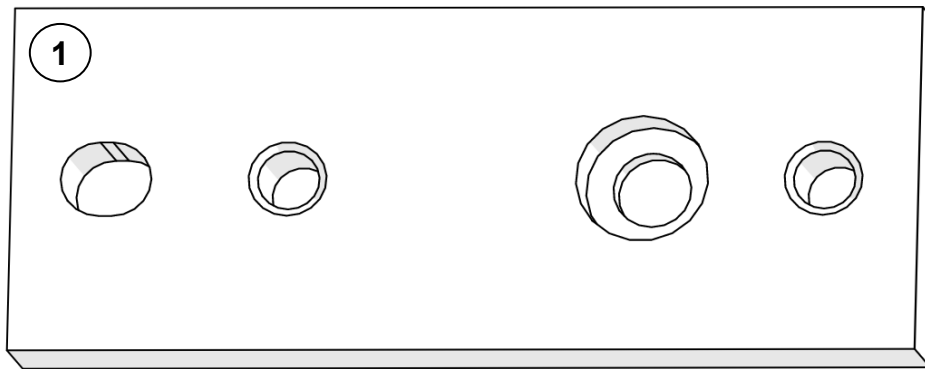
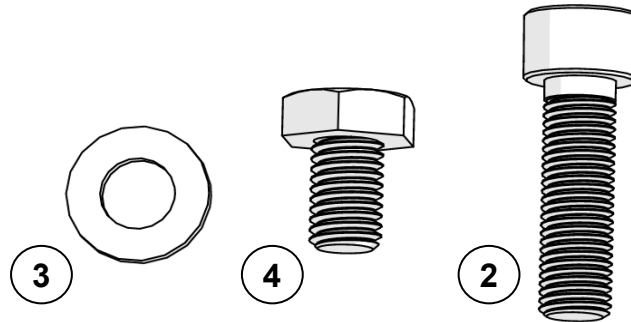

Item ID	Part Number	Name	QTY
1	23-02-05-001	Mounting Hardware (S), Bracket, Sway bar, Front / Relocation / Toyota	2
2	52-02-02-004	Fastener (S), Socket Head Cap Screw, Alloy Steel, M10-1.25 X 35mm / Zinc	2
3	52-04-02-003	Fastener (S), Washer, Alloy Steel, M10 X 20mm / Zinc	4
4	52-08-02-004	Fastener (S), Hex Cap Screw, Alloy Steel, M10-1.5 X 16mm / 10.9 / Zinc	4

Important Notes:

Prior to beginning this install, or any installation, read through the instructions entirely to familiarize yourself with the required steps and evaluate if you are experienced and/or capable to personally perform these step and modifications. A factory service manual should be used in conjunction with these instructions and installation.

Refer to the parts list to ensure that all necessary components and hardware has been included. If any parts are missing please contact your local TeraFlex dealer for assistance.

Tools needed:

- 17mm Socket
- 8mm Hex Bit Socket
- General Mechanics Tools
- Blue Threadlocker

1. Remove factory bolts (1) from the sway bar brackets.

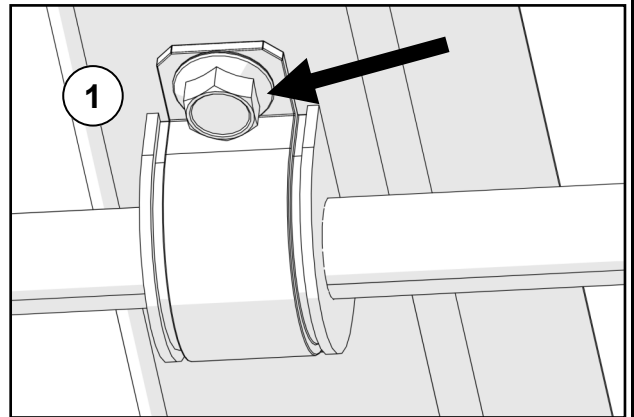

2. Apply blue threadlocker to 2 of the factory bolts and to all 6 of the bolts supplied in this kit.

Install relocation brackets in place of sway bar brackets, with a factory bolt (2) in the rear most elongated hole and a M10 socket head bolt (3) in the recessed hole, as shown.

Torque both bolts to 37 ft - lbs. [50Nm.]

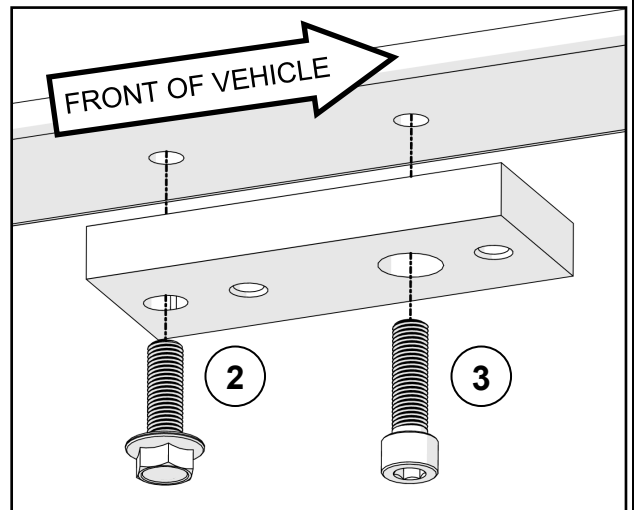

3. Loosely install one M10 hex head bolt and washer (4) into the rear most threaded hole of the relocation brackets. Then position the rear slotted hole of the sway bar bracket onto the bolt, as shown.

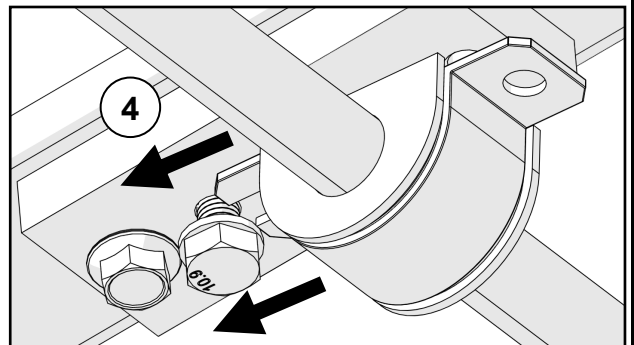

4. Lift the other end of the sway bar brackets and install the remaining M10 bolts and washers (5), as shown.

Torque bolts to 37 ft - lbs. [50 Nm].

Relocation brackets are aluminum, take care to not over tighten bolt.

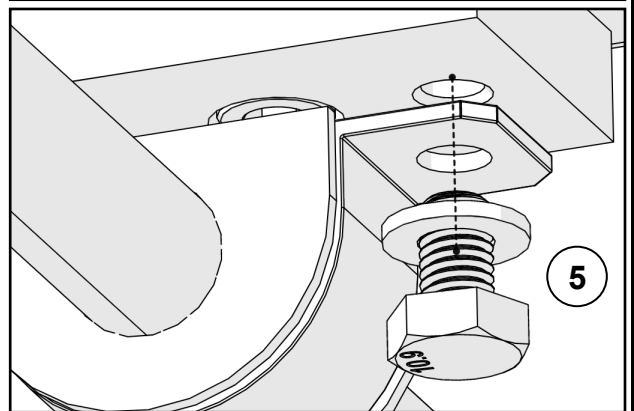



05-Current Toyota Tacoma Stock Wheels Alignment Tab

www.TERAFLEX.com

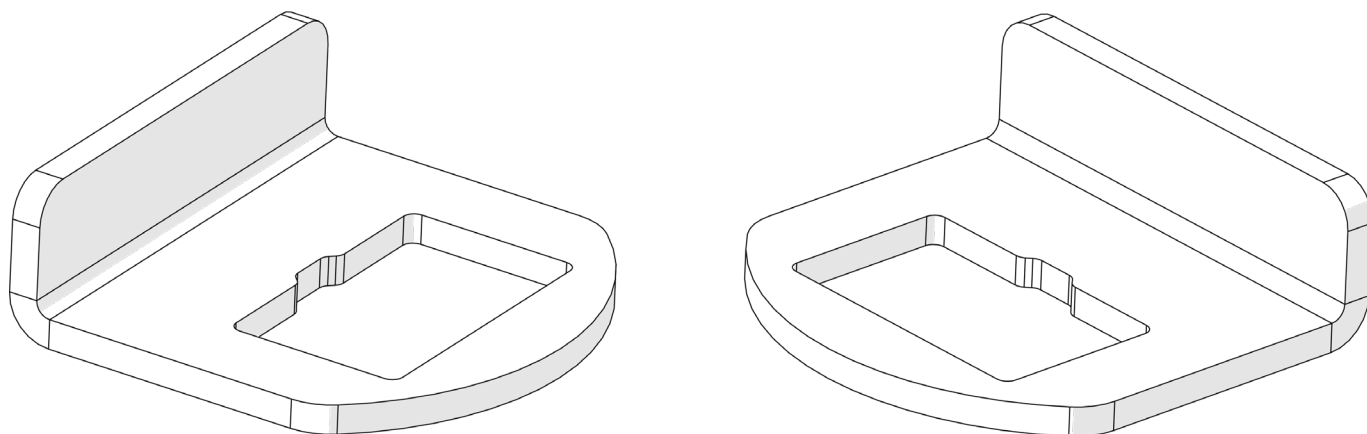

Important Notes:

Prior to beginning this install, or any installation, read the instructions thoroughly to familiarize yourself with the required steps. Evaluate if you are experienced and capable to personally perform these modifications. A factory service manual should be used in conjunction with these installation instructions.

This product will change the highway handling characteristics of your vehicle, exercise caution. After altering the suspension it is always advisable to have an alignment done by a competent 4 wheel drive shop or by an alignment shop that is experienced with lifted 4 wheel drive vehicles.

Refer to the parts list to ensure that all necessary components and hardware has been included. If any parts are missing please contact your local TeraFlex dealer for assistance.

When reinstalling OEM hardware, refer to the torque specs given in the Factory Service Manual.

Tools Needed:

- Cut off wheel
- Marker
- Grinder
- Tape Measure
- Drill

NOTE: FALCON SHOCKS COME ASSEMBLED WITH AN ALIGNMENT TAB MEANT FOR AFTERMARKET WHEELS. IF YOU ARE PLANNING ON RUNNING STOCK WHEELS, YOU WILL HAVE TO TRIM THE REAR SHOCK BUCKET AND USE THESE ALIGNMENT TABS TO KEEP THE SHOCK FROM RUBBING ON THE TIRE DURING FULL ARTICULATION OF THE SUSPENSION.

REAR SHOCK BUCKET BEFORE TRIM

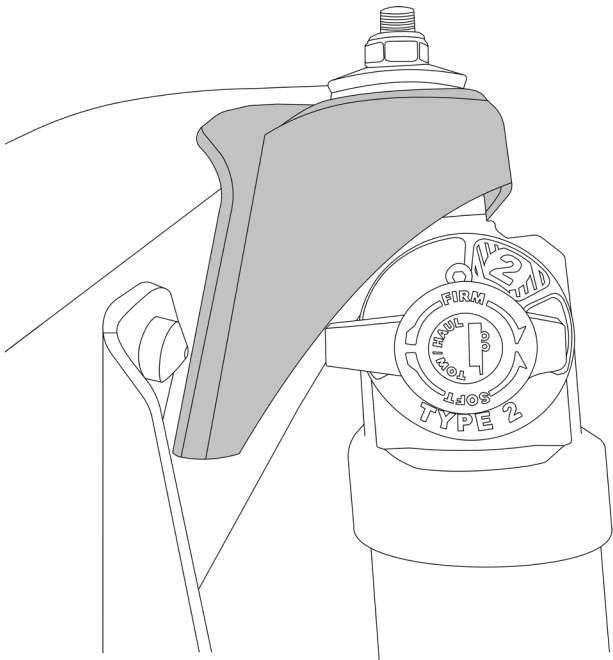

REAR SHOCK BUCKET AFTER TRIM

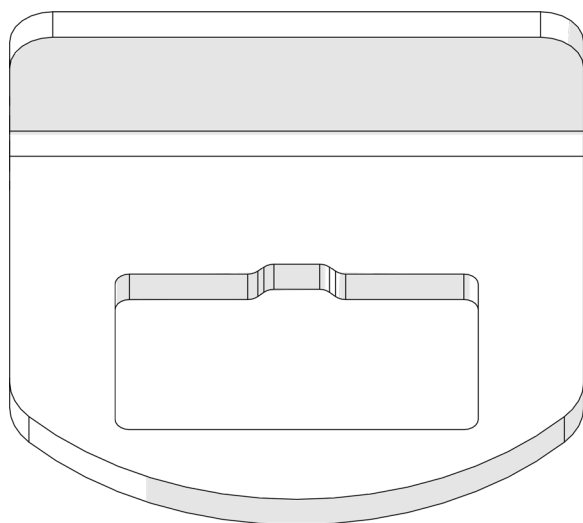
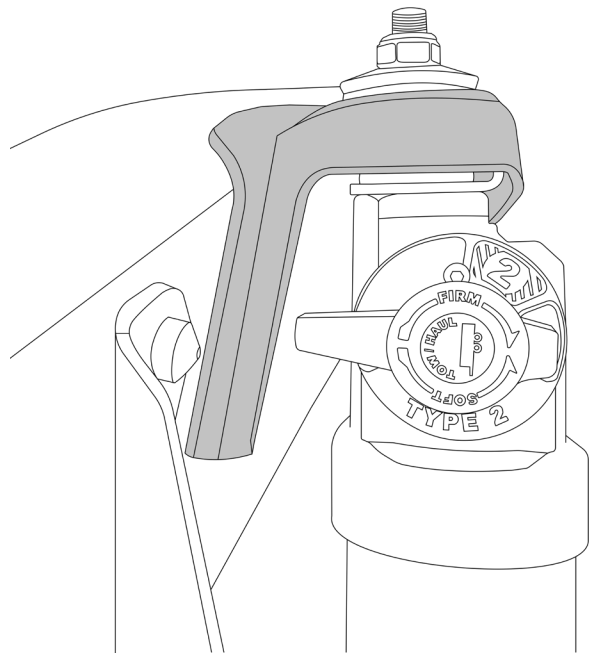

STOCK WHEELS

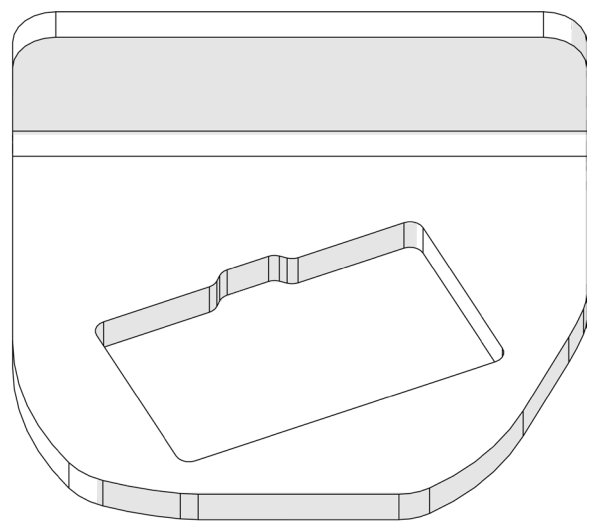

AFTERMARKET WHEELS

Using a tape measure make a mark $1\frac{3}{4}$ " towards the frame and 1" down from the top of the bucket. Use a $\frac{1}{2}$ " drill bit and make a hole.

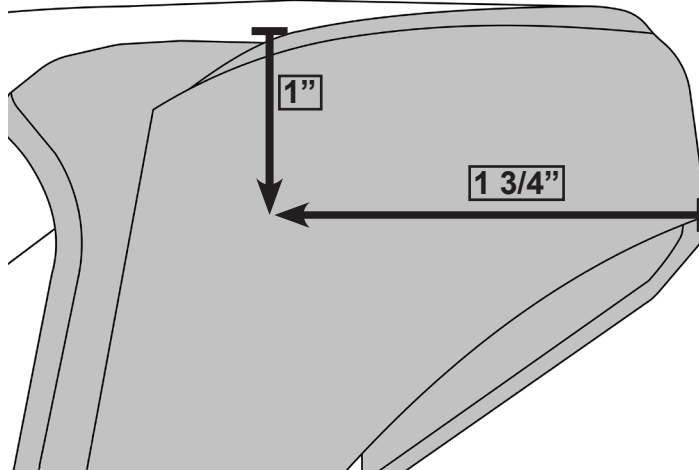

1

Use a Cutting Wheel to cut a straight line from the edges of the $\frac{1}{2}$ " hole.

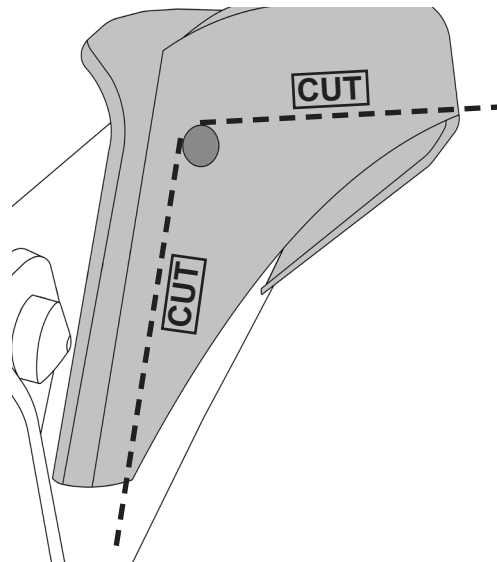

2

The drivers side has an extra bracket inside the shock bucket. This will also need to be cut.

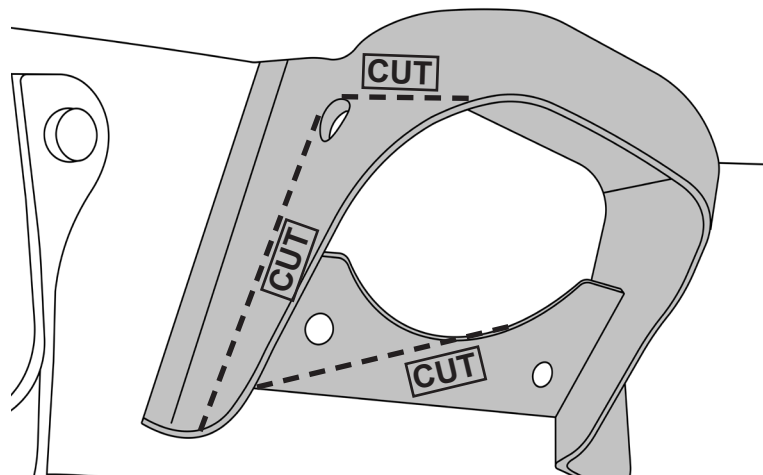

3

This is what the rear driver side should look like once the cuts are complete.

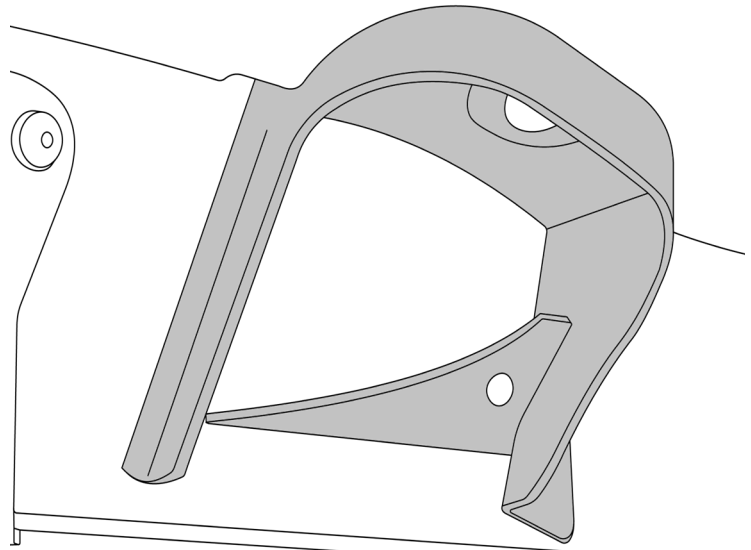

4

Use a grinder to smooth out the rough edges and apply a coat of spray paint to keep the buckets from rusting. Install your new Falcon shocks with the included alignment tabs.

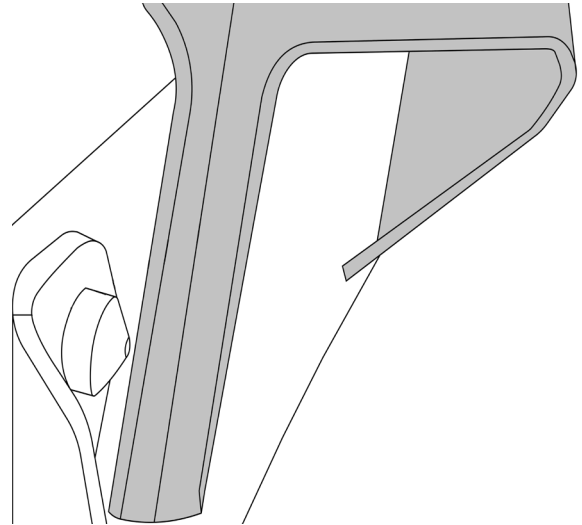

5

TERAFLEX

PRODUCT INFORMATION

MAINTENANCE INFORMATION:

It is the buyer's responsibility to have all suspension, drivetrain, steering, and other components checked for proper tightness and torque after the first 100 miles and every 3000 miles after that.

NOTICE TO INSTALLER:

The enclosed "Warning to Driver" sticker must be installed in the vehicle in driver's view. This sticker is to act as a constant safety reminder when operating the vehicle. It is your responsibility as the equipment installer to install the provided sticker and to forward the product instructions to the vehicle's owner for review. If a "Warning to Driver" sticker or product installation guide were not included in the kit, FREE replacement stickers and instructions are available by request. It is the installer's duty to ensure a safe and controllable vehicle after the modifications have been performed.

WARNING:

Neither the seller nor the manufacturer will be liable for any loss, damage, or injury directly or indirectly arising from the use of or inability to determine the use of these products. Before using, the user shall determine the suitability of the products for its intended use, and the user shall assume all responsibility and risk in connection therewith.

WARNING TO DRIVER:

This vehicle has been modified to enhance off road performance and has unique handling characteristics. Use in harsh environments can cause extreme stress on the components. Vehicle should be inspected after being off road to make sure that all the components are in working order and safe to travel on the highway. All fasteners should be checked so that they are at the correct torque specifications as the vibration and stresses from off roading may cause critical fasteners to work loose. Extra care should be taken to inspect the critical components, steering, and brake systems. During each oil change components such as arms, tie rod ends, etc should be greased and checked for excessive wear. Any worn components should be replaced. When returning to the pavement always set or restore tire air pressure to the factory recommendation and connect or engage any disabled sway bar mechanisms. Because of the higher center of gravity and larger tires, this vehicle handles and reacts differently than many passenger cars, both on and off road. You must drive it safely! Extreme care should be taken to prevent vehicle rollover or loss of control, which can result in serious injury or death. Avoid sudden sharp turns or abrupt maneuvers. Generally, braking performance and capabilities are decreased when significantly larger/heavier tires are used, especially when used in combination with transfer case low-range reduction kits. Take this into consideration while driving. Do not add, alter or fabricate any factory or aftermarket parts to increase vehicle height over the intended height of the TeraFlex product purchased. Mixing component brand is not recommended. TeraFlex Inc. will not be responsible for any altered product or any improper installation or use of our products. We will be happy to answer any questions concerning the design, function, and correct use of our products. It is ultimately the buyer's responsibility to have all bolts/nuts checked for tightness after the first 100 miles and then every 3000 miles. Wheel alignment, steering system, suspension and drive line systems must be inspected by a qualified professional mechanic at least every 3000 miles.

TERAFLEX PRODUCT WARRANTY:

TeraFlex Inc. warrants TeraFlex Suspension products to the original retail purchaser to be free of defects in material and workmanship for as long as the original purchaser owns the vehicle on which products were originally installed.

Failure to complete regular maintenance (grease every 3000 miles) on TeraFlex FlexArms will void this warranty. All other conditions of the standard TeraFlex product warranty apply.

All TeraLow products are covered by the TeraFlex two (2) year warranty to be free of defects in material and workmanship for two years from date purchased.

TeraFlex axles are covered by a 12-month warranty to be free of defects in materials and workmanship.

This warranty does not cover or include product finish, improperly installed or applied products, improperly maintained products, products or components used for racing or competition or damage due to abuse or neglect, products that fail due to the use of larger tire and wheel combinations.

All returns must be accompanied by an original invoice. It is the customer's responsibility to remove the product from the vehicle. Shipping charges are the responsibility of the customer. TeraFlex Inc. will pay the return freight if the product meets the terms of warranty.

This warranty is for the replacement or repair of defective TeraFlex products only and does not include freight charges, labor charges for removal of or installation of TeraFlex or related products or components, costs incurred due to down time of the vehicle, or lost profits due to vehicle down time.

A returned goods authorization number (RGA#) must accompany any returned products. For more information please contact a TeraFlex customer service representative.

COPYRIGHT

©Copyright 2014. All rights reserved, TeraFlex Inc. Reproduction of this catalog and/or any of its contents without written permission is strictly prohibited.

TeraFlex® is a registered trademark of TeraFlex Inc. All trade names and logos including but not limited to TeraFlex, FlexArms, RockGuard, Monster, and LCG are protected by law and duplication of trade names and/or logos are strictly prohibited.

TeraFlex Inc. reserves the right to update, discontinue, redesign, modify finish, part number or component build parts if deemed necessary without written notice. TeraFlex Inc., and any associated dealers are not responsible for misprints or typographical errors that may have inadvertently been made within this instruction sheet.

Jeep® and the Jeep® grill are registered trademarks of Fiat Chrysler Automobiles N.V., and have no affiliation with TeraFlex Inc.

TERAFLEX, Inc.
5680 West Dannon Way
West Jordan, UT. 84081
Phone/801.713.3314
Fax/801.713.2313
www.teraflex.com

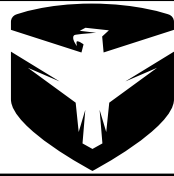

GREASE INSTRUCTIONS

www.falconshocks.com

Grease front lower coilover bearings every 2500 miles for best performance and to avoid premature wear. From the factory, your bearings were packed with Red Line CV-2 Extreme Pressure Synthetic Grease, this is what Falcon recommends you use for maintenance throughout the life of the shock.

To Fill: Watch closely as you slowly pump grease into the zerk (shown below), and stop as soon as you see movement from the black rubber seals on either side of the bearing. **DO NOT OVERFILL.** Seals must remain fully seated to prevent premature wear.

